

BIRLA INSTITUTE OF TECHNOLOGY



CHOICE BASED CREDIT SYSTEM (CBCS) CURRICULUM

(Effective from Academic Session: Monsoon 2021)

NAME OF THE PROGRAMME

B.TECH. Electronics and Communication Engineering

NAME OF THE DEPARTMENT

Department of Electronics and Communication Engineering

Institute Vision

To become a Globally Recognised Academic Institution in consonance with the social, economic and ecological environment, striving continuously for excellence in education, research, and technological service to the National needs.

Institute Mission

- To educate students at Under Graduate, Post Graduate, Doctoral, and Post-Doctoral levels to perform challenging engineering and managerial jobs in industry.
- To provide excellent research and development facilities to take up Ph.D. programmes and research projects.
- To develop effective teaching learning skills and state of art research potential of the faculty.
- To build national capabilities in technology, education, and research in emerging areas.
- To provide excellent technological services to satisfy the requirements of the industry and overall academic needs of society.

Department Vision:

To become a centre of excellence in teaching and research for creating technical manpower to meet the technological, societal and environmental needs of the country in the field of Electronics and Communication Engineering.

Department Mission

- To offer state of the art education of global standards through innovative methods of teaching and learning with practical orientation aiming to prepare the students for successful career and to provide required technological services.
- To prepare the students to think independently, take initiative, lead a team in an organization, take responsibility and solve the problems related to industry, society, environmental, health, safety, legal and cultural issues maintaining the professional ethics.
- To pursue high quality contemporary research through continued interaction with research organizations and industries.

Graduate Attributes

1. **Engineering Knowledge:** Apply knowledge of mathematics, science, engineering fundamentals and an engineering specialization to the solution of complex engineering problems.
2. **Problem Analysis:** Identify, formulate, research literature and analyze complex engineering problems reaching substantiated conclusions using first principles of mathematics, natural sciences and engineering sciences.
3. **Design/ Development of Solutions:** Design solutions for complex engineering problems and design system components or processes that meet specified needs with appropriate consideration for public health and safety, cultural, societal and environmental considerations.
4. **Conduct investigations of complex problems** using research-based knowledge and research methods including design of experiments, analysis and interpretation of data and synthesis of information to provide valid conclusions.
5. **Modern Tool Usage:** Create, select and apply appropriate techniques, resources and modern engineering and IT tools including prediction and modelling to complex engineering activities with an understanding of the limitations.
6. **The Engineer and Society:** Apply reasoning informed by contextual knowledge to assess societal, health, safety, legal and cultural issues and the consequent responsibilities relevant to professional engineering practice.

7. **Environment and Sustainability:** Understand the impact of professional engineering solutions in societal and environmental contexts and demonstrate knowledge of and need for sustainable development.
8. **Ethics:** Apply ethical principles and commit to professional ethics and responsibilities and norms of engineering practice.
9. **Individual and Team Work:** Function effectively as an individual, and as a member or leader in diverse teams and in multi-disciplinary settings.
10. **Communication:** Communicate effectively on complex engineering activities with the engineering community and with society at large, such as being able to comprehend and write effective reports and design documentation, make effective presentations and give and receive clear instructions.
11. **Project Management and Finance:** Demonstrate knowledge and understanding of engineering and management principles and apply these to one's own work, as a member and leader in a team, to manage projects and in multidisciplinary environments.
12. **Life-long Learning:** Recognize the need for and have the preparation and ability to engage in independent and life-long learning in the broadest context of technological change.

Programme Educational Objectives (PEOs)

1. To develop an ability to apply the knowledge acquired in basic sciences and engineering for solving Electronics and Communication Engineering problems with regards to technical, economic, environmental and social contexts.
2. To build confident and competent graduates capable of designing and testing electronic devices and communication systems for the given specifications.
3. To inculcate an attitude to work in a team using technical knowhow, software tools and interdisciplinary working environments to achieve project goals.
4. To nurture effective communication and interpersonal skills to demonstrate leadership qualities, and exhibit professional ethics.
5. To develop an ability, enthusiasm and understanding for life-long learning development and motivation towards higher studies and research.

(A) Programme Outcomes (POs)

Engineering Graduates will be able to:

1. **Engineering knowledge:** Apply the knowledge of mathematics, science, engineering fundamentals, and an engineering specialization to the solution of complex engineering problems.

2. **Problem analysis:** Identify, formulate, review research literature, and analyze complex engineering problems reaching substantiated conclusions using first principles of mathematics, natural sciences, and engineering sciences.
3. **Design/development of solutions:** Design solutions for complex engineering problems and design system components or processes that meet the specified needs with appropriate consideration for the public health and safety, and the cultural, societal, and environmental considerations.
4. **Conduct investigations of complex problems:** Use research-based knowledge and research methods including design of experiments, analysis and interpretation of data, and synthesis of the information to provide valid conclusions.
5. **Modern tool usage:** Create, select, and apply appropriate techniques, resources, and modern engineering and IT tools including prediction and modeling to complex engineering activities with an understanding of the limitations.
6. **The engineer and society:** Apply reasoning informed by the contextual knowledge to assess societal, health, safety, legal and cultural issues and the consequent responsibilities relevant to the professional engineering practice.
7. **Environment and sustainability:** Understand the impact of the professional engineering solutions in societal and environmental contexts, and demonstrate the knowledge of, and need for sustainable development.
8. **Ethics:** Apply ethical principles and commit to professional ethics and responsibilities and norms of the engineering practice.
9. **Individual and team work:** Function effectively as an individual, and as a member or leader in diverse teams, and in multidisciplinary settings.
10. **Communication:** Communicate effectively on complex engineering activities with the engineering community and with society at large, such as, being able to comprehend and write effective reports and design documentation, make effective presentations, and give and receive clear instructions.
11. **Project management and finance:** Demonstrate knowledge and understanding of the engineering and management principles and apply these to one's own work, as a member and leader in a team, to manage projects and in multidisciplinary environments.
12. **Life-long learning:** Recognize the need for, and have the preparation and ability to engage in independent and life-long learning in the broadest context of technological change.

(B) Programme Specific Outcomes (PSOs)

1. Apply the knowledge acquired in basic sciences and engineering for solving electronics and communication engineering problems.
2. Build competence in design and analysis of electronics and communication systems.
3. Develop skills to carry out research in electronic instrumentation, signal processing, VLSI systems, microwave engineering, wireless communication and networking.

PROGRAMME COURSE STRUCTURE (Only 1st Year for 2021-22 Batch)

BIRLA INSTITUTE OF TECHNOLOGY- MESRA, RANCHI
NEW COURSE STRUCTURE - To be effective for B. Tech 2021-22
Based on CBCS system & OBE model
Recommended scheme of study
(For Circuit Branches)

Semester of Study (Recommended)	Category of course	Course Code (TBD) XX100x	Subjects	Mode of delivery & credits <i>L-Lecture; T-Tutorial; P-Practical (Periods /week)</i>			Total Credits <i>C- Credits</i>	
				L	T	P		C
THEORY								
FIRST	FS <i>Foundation Sciences</i>	MA103	Mathematics - I	3	1	0	4	
		CH101	Chemistry	3	1	0	4	
	GE <i>General Engineering</i>	EC101	Basic of Electronics and Communication Engineering	3	1	0	4	
		ME101	Basic of Mechanical Engineering	3	1	0	4	
	FS	CE101	Environmental Sciences	2	0	0	2	
	LABORATORIES							
	FS	CH102	Chemistry Lab	0	0	3	1.5	
	GE	EC102	Electronics and Communication Lab	0	0	3	1.5	
		ME102	Engineering Graphics	0	0	4	2	
	MC <i>Mandatory Course</i>	MC101/ 102/103 /104	Choice of: NCC/NSS/ PT & Games/ Creative Arts (CA)	0	0	2	1	
TOTAL (Theory + Labs)							24	
THEORY								
SECOND	FS	MA107	Mathematics - II	3	1	0	4	
		PH113	Physics	3	1	0	4	
		BE101	Biological Sciences	2	0	0	2	
	GE	CS101	Programming for problem Solving	3	1	0	4	
		EE101	Basics of Electrical Engineering	3	1	0	4	
	LABORATORIES							
	FS	PH114	Physics Lab	0	0	3	1.5	
	GE	CS102	Programming for problem Solving laboratories	0	0	3	1.5	
		PE101	Workshop Practice	0	0	3	1.5	
	MC	MC105/ 106/107 /108	Choice of: NCC/NSS/ PT & Games/ Creative Arts (CA)	0	0	2	1	
TOTAL (Theory + Labs)							23.5	
GRAND TOTAL FOR FIRST YEAR							47.5	

PROGRAMME COURSE STRUCTURE (Only 1st Year for 2020-21 Batch)

BIRLA INSTITUTE OF TECHNOLOGY- MESRA, RANCHI

1ST Year COURSE STRUCTURE - for B. Tech 2020-21 Batch

Based on CBCS system & OBE model

Recommended scheme of study

(For Circuit Branches)

Semester of Study (Recommended)	Category of course	Course Code (TBD) XX100x	Subjects	Mode of delivery & credits <i>L-Lecture; T-Tutorial; P-Practical (Periods /week)</i>			Total Credits <i>C-Credits</i>	
				L	T	P		C
THEORY								
FIRST	FS Foundation Sciences	MA103	Mathematics - I	3	1	0	4	
		CH101	Chemistry	3	1	0	4	
	GE General Engineering	EC101	Basic of Electronics and Communication Engineering	3	1	0	4	
		ME101	Basic of Mechanical Engineering	3	1	0	4	
	LABORATORIES							
	FS & GE	CH102	Chemistry Lab	0	0	3	1.5	
		EC102	Electronics and Communication Lab	0	0	3	1.5	
		ME102	Engineering Graphics	0	0	4	2	
	MC Mandatory Course	MC101/ 102/103 /104	Choice of: NCC/NSS/ PT & Games/ Creative Arts (CA)	0	0	2	1	
	TOTAL (Theory + Labs)							22
THEORY								
SECOND	FS	MA107	Mathematics - II	3	1	0	4	
		PH113	Physics	3	1	0	4	
	GE	CS101	Programming for problem Solving	3	1	0	4	
		EE101	Basics of Electrical Engineering	3	1	0	4	
	LABORATORIES							
	FS	PH114	Physics Lab	0	0	3	1.5	
	GE	CS102	Programming for problem Solving laboratories	0	0	3	1.5	
		PE101	Workshop Practice	0	0	3	1.5	
	MC	MC105/ 106/107 /108	Choice of: NCC/NSS/ PT & Games/ Creative Arts (CA)	0	0	2	1	
	TOTAL (Theory + Labs)							21.5
GRAND TOTAL FOR FIRST YEAR							43.5	

PROGRAMME COURSE STRUCTURE (2nd Year Onwards for 2020-21 Batch)								
BIRLA INSTITUTE OF TECHNOLOGY- MESRA, RANCHI								
NEW COURSE STRUCTURE – To be effective for B.Tech. 2020-21 [2nd Year Onwards]								
Based on CBCS system & OBE model								
Recommended scheme of study								
(For B.Tech. in Electronics & Communications Engineering)								
Semester of Study (Recommended)	Category of course	Course Code	Subjects	Mode of delivery & credits			Total Credits C-Credit	
				<i>L-Lecture;</i>	<i>T-Tutorial;</i>	<i>P-Practicals</i>		
				L	T	P	C	
THEORY								
THIRD	GE	IT 201	Basics of Intelligent Computing	3	0	0	3	
	FS	BE101	Biological Sciences for Engineering	2	0	0	2	
	PC	EC201	Electronic Devices		3	0	0	3
		EC203	Digital System Design		3	0	0	3
		EC205	Signals and Systems		3	0	0	3
		EC207	Electronic Measurements		3	0	0	3
		EC209	Network Theory		3	0	0	3
	LABORATORIES							
	GE	EE102	Electrical Engineering lab		0	0	3	1.5
	MC	MC201/ 202/203/204	Choice of: NCC/NSS/ PT & Games/ Creative Arts (CA)		0	0	2	1
	PC	EC202	Electronic Devices Lab		0	0	3	1.5
EC204		Digital System Design Lab		0	0	3	1.5	
TOTAL (Theory + Labs)							25.5	
THEORY								
FOURTH	FS	MA203	Numerical Methods	2	0	0	2	
	FS	CE101	Environmental Science	2	0	0	2	
	HSS	MT131	UHV2: Understanding Harmony	3	0	0	3	
	PC	EC251	Probability and Random Processes		3	0	0	3
		EC253	Analog Circuits		3	0	0	3
		EC257	Electromagnetic Fields and Waves		3	0	0	3
	OE		Open Elective-I		3	0	0	3
	LABORATORIES							
	FS	MA204	Numerical Methods Lab		0	0	2	1
	GE	IT202	Basic IT Workshop		0	0	2	1
	MC	MC201/ 202/203/204	Choice of : NCC/NSS/ PT & Games/ Creative Arts (CA)		0	0	2	1
PC	EC208	Electronic Measurement Lab		0	0	3	1.5	
	EC254	Analog Circuits Lab		0	0	3	1.5	
TOTAL (Theory + Labs)							25	
GRAND TOTAL FOR SECOND YEAR							50.5	

BIRLA INSTITUTE OF TECHNOLOGY- MESRA, RANCHI
NEW COURSE STRUCTURE – To be effective for B.Tech. 2020-21
Based on CBCS system & OBE model
Recommended scheme of study
(For B.Tech. in Electronics & Communications Engineering)

Semester of Study (Recommended)	Category of course	Course Code	Subjects	Mode of delivery & credits			Total Credits C- Credits	
				L	T	P		
THEORY								
FIFTH	PC	EC301	Analog Communication	3	0	0	3	
		EC303	Microprocessors and Microcontrollers	3	0	0	3	
		EC305	Signal Processing Techniques	3	0	0	3	
		EC307	Control Systems	3	0	0	3	
		EC319	VLSI System	3	0	0	3	
	OE		Open Elective-II	3	0	0	3	
	LABORATORIES							
			EC304	Microprocessors and Microcontrollers Lab	0	0	3	1.5
			EC306	Signal Processing Lab	0	0	3	1.5
			EC320	VLSI System Lab	0	0	3	1.5
TOTAL (Theory + Labs)							22.5	
THEORY								
SIXTH	PC	EC351	Data Communication	3	0	0	3	
		EC353	Digital Communication	3	0	0	3	
	PE		Program Elective-I	3	0	0	3	
	OE		Open Elective-III	3	0	0	3	
	HSS	MT123	Business Communications	2	0	0	2	
		MT204	Constitution of India	2	0	0	0 Non-credit	
	MC	MC300	Summer training – Mandatory				3	
	LABORATORIES							
	PC	EC352	Fiber Optic Communication Lab	0	0	3	1.5	
		EC354	Communication System Lab	0	0	3	1.5	
TOTAL (Theory + Labs)							20	
GRAND TOTAL FOR THIRD YEAR							42.5	

BIRLA INSTITUTE OF TECHNOLOGY- MESRA, RANCHI
NEW COURSE STRUCTURE – To be effective for B.Tech. 2020-21
Based on CBCS system & OBE model
Recommended scheme of study
(For B.Tech. in Electronics & Communications Engineering)

Semester of Study (Recommended)	Category of course	Course Code	Subjects	Mode of delivery & credits			Total Credits <i>C- Credit</i>	
				L	T	P		
THEORY								
SEVENTH	PC	EC401	Microwave Theory and Techniques	3	0	0	3	
			Program Elective-II	3	0	0	3	
			Program Elective-III	3	0	0	3	
			Program Elective-IV	3	0	0	3	
	OE		Open Elective-IV	3	0	0	3	
	LABORATORIES							
	PC	EC402	Microwave Lab	0	0	3	1.5	
		EC404	Advanced Communication Lab	0	0	3	1.5	
		EC406	Industrial Automation Lab	0	0	3	1.5	
	TOTAL (Theory + Labs)							19.5
THEORY								
EIGHTH	PC	EC450	Research Project/Industry Internship	0	0	0	12	
GRAND TOTAL FOR FOURTH YEAR							31.5	
GRAND TOTAL							168	

DEPARTMENT OF ELECTRONICS AND COMMUNICATION ENGINEERING
PROGRAMME ELECTIVES (PE)*

SEMESTER	Code no.	Name of the PE courses	Prerequisite/ Corequisite courses with code	L	T	P	C
PE-I							
SEM-VI	EC355	Fiber Optic Communication	EC201 Electronic Devices EC257 Electromagnetic Fields and Waves	3	0	0	3
	EC357	Introduction to Industrial Instrumentation	EC207 Electronic Measurements	3	0	0	3
	EC359	Information Theory and Coding	EC251 Probability and Random Process, EC301 Analog Communication	3	0	0	3
PE-II							
SEM-VII	EC403	Mobile & Cellular Communication	EC301 Analog Communication, EC353 Digital Communication	3	0	0	3
	EC405	Industrial Electronics	EC253 Analog Circuits	3	0	0	3
	EC407	Computer Networking	EC351 Data Communication	3	0	0	3
PE-III							
SEM- VII	EC409	Wireless Communication	EC301 Analog Communication, EC353 Digital Communication	3	0	0	3
	EC411	Speech and Audio Processing	EC205 Signals and Systems, EC305 Signal Processing Techniques EC251 Probability and Random Processes	3	0	0	3
	EC413	Microcontrollers and Interfacing	EC303 Microprocessors and Microcontrollers	3	0	0	3
	EC415	Neural Networks and Fuzzy System	EC205 Signals and Systems, EC305 Signal Processing Techniques				
PE-IV							
SEM-VII	EC417	Satellite Communication	EC301 Analog Communication, EC353 Digital Communication	3	0	0	3
	EC419	Radar Engineering	EC257 Electromagnetic Fields and Waves	3	0	0	3
	EC421	Real Time Embedded System	EC203 Digital System Design EC303 Microprocessors and Microcontrollers	3	0	0	3
	EC423	Bio-Medical Electronics & Signal Processing	EC205 Signals and Systems, EC305 Signal Processing Techniques EC251 Probability and Random Processes	3	0	0	3
	EC425	Low Power VLSI Circuits	EC101 Basics of Electronics and Communication Engineering, EC201 Electronic Devices	3	0	0	3
	EC427	ASIC Design	EC101 Basics of Electronics and Communication Engineering, EC201 Electronic Devices, EC319 VLSI Systems	3	0	0	3
	EC429	Time Frequency and Wavelet Transform	EC205 Signals and Systems, EC305 Signal Processing Techniques, EC251 Probability and Random Processes	3	0	0	3
	EC431	Digital Image & Video Processing	EC305 Signal Processing Techniques	3	0	0	3
	EC433	Wireless Sensors networks	EC351 Data Communication	3	0	0	3
	EC435	Nanoelectronics	EC101 Basics of Electronics and Communication Engineering, EC201 Electronic Devices	3	0	0	3
* PROGRAMME ELECTIVES TO BE OPTED ONLY BY THE DEPARTMENT STUDENTS							

DEPARTMENT OF ELECTRONICS AND COMMUNICATION ENGINEERING
OPEN ELECTIVES (OE)*

SEMESTER	Code No.	Name of the OE courses	Prerequisites courses with code	L	T	P	C
		OE-I					
FOURTH	EC259	Sensors and Transducers	N/A	3	0	0	3
		OE-II					
FIFTH	EC321	Introduction to Communication System	N/A	3	0	0	3
		OE-III					
SIXTH	EC361	Introduction to MEMS	N/A	3	0	0	3
		OE-IV					
SEVENTH	EC437	Introduction to Signal Processing	N/A	3	0	0	3
* OPEN ELECTIVES TO BE OPTED ONLY BY OTHER DEPARTMENT STUDENTS							

BIRLA INSTITUTE OF TECHNOLOGY- MESRA, RANCHI
NEWCOURSE STRUCTURE - To be effective from academic session 2020-21 Based on CBCS & OBE model
Recommended scheme of study for *In-depth Specialization in*
Signal Processing and Embedded System

Semester/ Session of Study (Recommended)	Course Level	Category of course	Course Code	Courses	Mode of delivery & credits <i>L-Lecture; T- Tutorial; P- Practical</i>			Total Credits <i>C-Credits</i>
					L	T	P	
THEORY								
FIFTH Monsoon	THIRD	PC	EC323	Embedded System Design	3	1	0	4
	LABORATORIES							
	THIRD	PC	EC324	Embedded System Design Lab	0	0	2	1
TOTAL								5
SIXTH Spring	THIRD	PC	EC363	Advanced Signal Processing Techniques	3	1	0	4
	LABORATORIE S							
	THIRD	PC	EC364	Advanced Signal Processing Techniques Lab	0	0	2	1
	THIRD	PC	EC350	Product Development Lab	0	0	0	3
TOTAL								8
SEVENTH Monsoon	FOURTH	PC	EC400	Specialization Project	0	0	0	5
TOTAL								5
GRAND TOTAL <i>Minimum requirement for In-depth Specialization award</i>								18

BIRLA INSTITUTE OF TECHNOLOGY- MESRA, RANCHI
NEWCOURSE STRUCTURE - To be effective from academic session 2020-21

Based on CBCS & OBE model

Recommended scheme of study for *In-depth Specialization in*
Microelectronics & VLSI Design

Semester/ Session of Study (Recommended)	Course Level	Category of course	Course Code	Courses	Mode of delivery & credits <i>L-Lecture;</i> <i>T-Tutorial;</i> <i>P-Practical</i>			Total Credits <i>C- Credits</i>
					L	T	P	
THEORY								
FIFTH Monsoon	THIRD	PC	EC325	Digital Systems Design with FPGAs	3	1	0	4
	LABORATORIE S							
	THIRD	PC	EC326	Digital Systems Design with FPGAs Lab	0	0	2	1
TOTAL								5
SIXTH Spring	THIRD	PC	EC365	Microelectronic Devices and Circuits	3	1	0	4
	LABORATORIES							
	THIRD	PC	EC366	Microelectronic Devices and Circuits Lab	0	0	2	1
	THIRD	PC	EC350	Product Development Lab	0	0	0	3
TOTAL								8
SEVENTH Monsoon	FOURTH	PC	EC400	Specialization Project	0	0	0	5
TOTAL								5
GRAND TOTAL <i>Minimum requirement for In-depth Specialization award</i>								18

BIRLA INSTITUTE OF TECHNOLOGY- MESRA, RANCHI
NEWCOURSE STRUCTURE - To be effective from academic session 2020-21
Based on CBCS & OBE model
Recommended scheme of study for *In-depth Specialization in*
RF and Wireless Communication System

Semester/ Session of Study (Recommended)	Course Level	Category of course	Course Code	Courses	Mode of delivery & credits <i>L-Lecture;</i> <i>T-Tutorial;</i> <i>P-Practical</i>			Total Credits <i>C- Credits</i>
					L	T	P	
THEORY								
FIFTH Monsoon	THIRD	PC	EC327	Antenna and Wave Propagation	3	1	0	4
	LABORATORIES							
	THIRD	PC	EC328	Antenna and Wave Propagation Lab.	0	0	2	1
TOTAL								5
SIXTH Spring	THIRD	PC	EC367	Wireless Networks	3	1	0	4
	LABORATORIES							
	THIRD	PC	EC368	Wireless Networks Lab	0	0	2	1
	THIRD	PC	EC350	Product Development Lab	0	0	0	3
TOTAL								8
SEVENTH Monsoon	FOURTH	PC	EC400	Specialization Project	0	0	0	5
TOTAL								5
GRAND TOTAL								18
<i>Minimum requirement for In-depth Specialization award</i>								

BIRLA INSTITUTE OF TECHNOLOGY- MESRA, RANCHI
NEWCOURSE STRUCTURE - To be effective from academic session 2020- 21

Based on CBCS & OBE model

Recommended scheme of study for

Minor in Electronics & Communications Engineering

Semester/ Session of Study (Recommended)	Course Level	Category of course	Course Code	Course	Mode of delivery & credits L- Lecture; T- Tutorial; P- Practicals			Total Credits C- Credits	
					L	T	P		C
THEORY									
FIFTH Monsoon	SECOND	PC	EC329	FPGA and ASIC Design	3	0	0	3	
			EC331	Communication System	3	0	0	3	
	LABORATORIES								
	SECOND	PC	EC332	Communication Lab	0	0	2	1	
TOTAL								7	
SIXTH Spring	SECOND	PC	EC369	Digital Signal Processing	3	0	0	3	
			EC371	Electronic Instrumentation	3	0	0	3	
	LABORATORIES								
	SECOND	PC	EC372	Digital Signal Processing & Instrumentation Lab	0	0	2	1	
TOTAL								7	
SEVENTH Monsoon	THIRD	PC	EC440	Project				6	
TOTAL								6	
GRAND TOTAL								20	
<i>Minimum requirement for Minor degree award</i>									

BLOOM'S TAXONOMY FOR CURRICULUM DESIGN AND ASSESSMENT:

Preamble

The design of curriculum and assessment is based on Bloom's Taxonomy. A comprehensive guideline for using Bloom's Taxonomy is given below for reference.

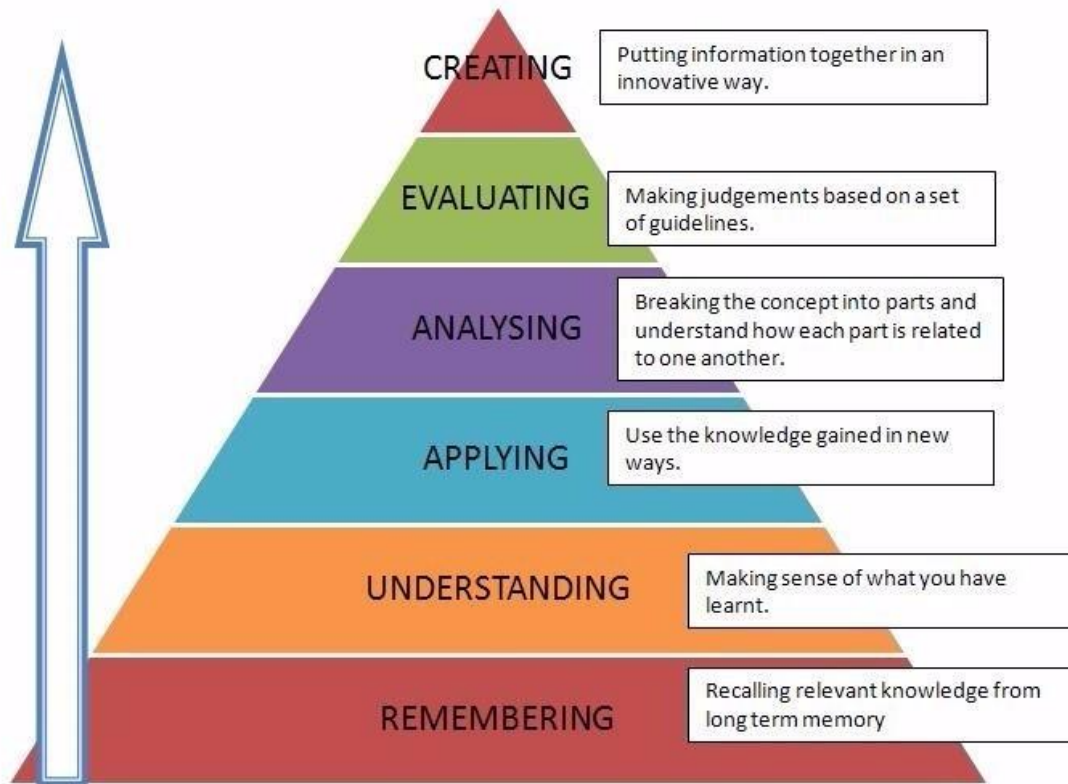

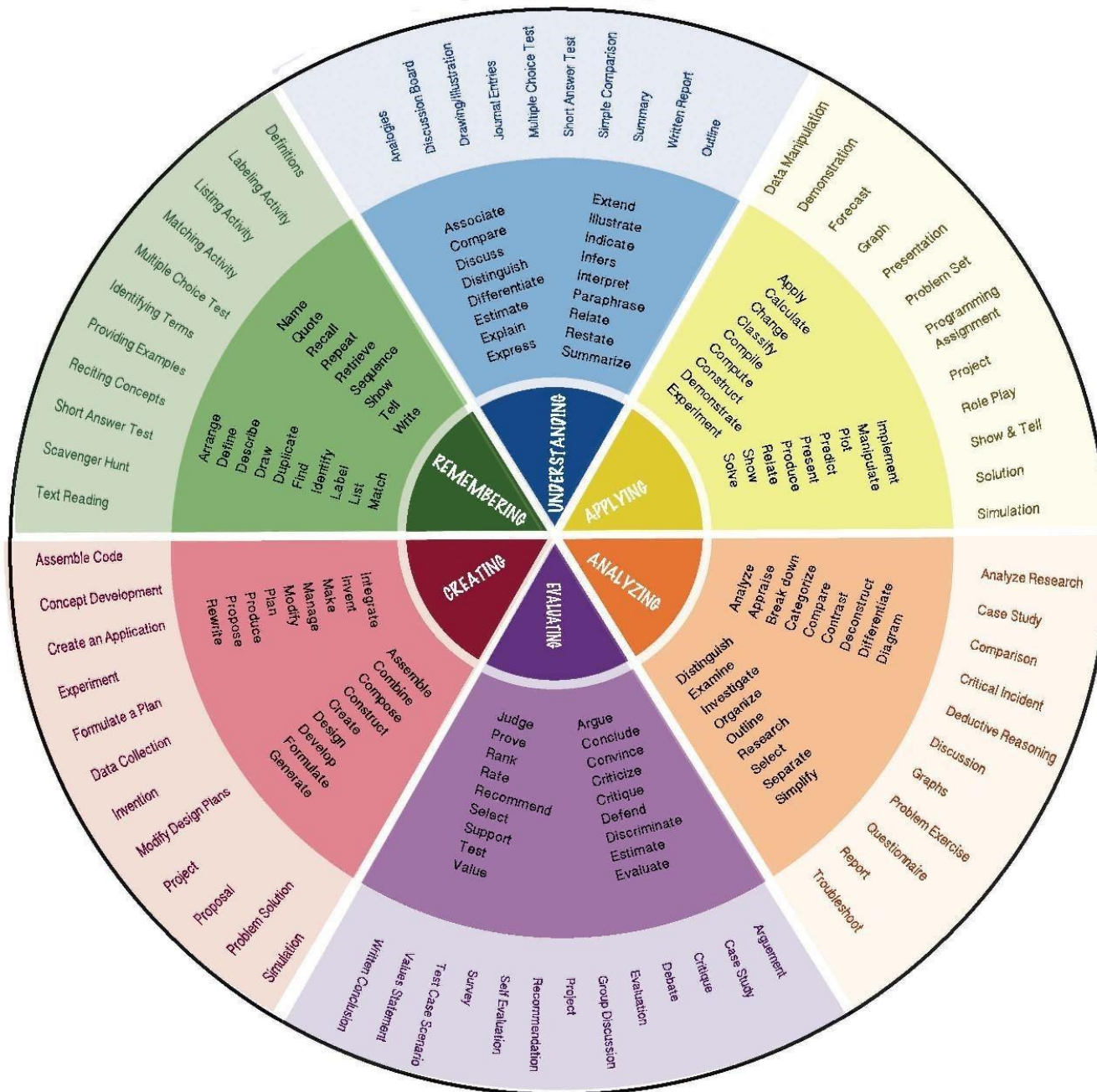

COURSE INFORMATION SHEET
Basics of Electronics & Communication Engineering

Course code: EC101

Course title: Basics of Electronics & Communication Engineering

Pre-requisite(s): N/A

Co- requisite(s): N/A

Credits: L: 3 T: 1 P: 0 C: 4 **Class schedule**
per week: 04 Class: B. Tech. Semester / Level:

01/01 Branch: ALL B. Tech.

Name of Teacher: All

Course Objectives:

This course enables the students:

1.	To understand PN Junction, diodes and their applications.
2.	To comprehend BJT, FET and their bias configurations.
3.	To grasp importance of feedback in amplifier circuits, op amp and its applications.
4.	To understand number system, Logic Gates and Boolean algebra.
5.	To apprehend fundamentals of communication technology.

Course Outcomes:

After the completion of this course, students will be able to:

CO1	Explain PN Junction, diodes and their applications.
CO2	Appraise the BJT, FET and their biasing techniques.
CO3	Comprehend feedback in amplifier circuits, op amp and its applications.
CO4	Translate one number system into another, build circuits with Logic Gates, electronic components and OPAMP IC 741 and analyze the measurement results using CRO.
CO5	Appraise the fundamentals of communication technology.

SYLLABUS

MODULE	(NO. OF LECTURE HOURS)
<p><u>Module-1</u> Diodes and Applications: Introduction to PN junction diodes; Characteristics of semiconductor diodes: V-I characteristics, diode-resistance, temperature dependence, diode-capacitance; DC & AC load lines; Breakdown Mechanisms; Zener Diode – Operation and Applications; Diode as a Rectifier: Half Wave and Full Wave Rectifiers with and without C-Filters.</p>	12
<p><u>Module-2</u> Bipolar Junction Transistors (BJT): PNP and NPN Transistors, Basic Transistor Action, Input and Output Characteristics of CB, CE and CC Configurations, dc and ac load line analysis, operating point, Transistor biasing: Fixed bias, emitter bias/self-bias, Low-frequency response of CE amplifier. Field Effect Transistors: JFET, Idea of Channel Formation, Pinch-Off and saturation Voltage, Current-Voltage Output Characteristics; MOSFET: Basic structure, operation and characteristics.</p>	12
<p><u>Module-3</u> Sinusoidal Oscillators: Concept of positive and negative feedback, Barkhausen criterion for sustained oscillations, Determination of Frequency and Condition of oscillation, Hartley and Colpitt's oscillator. Operational Amplifiers: Characteristics of an Ideal and Practical Operational Amplifier (IC 741), Inverting and non-inverting amplifiers, Offset error voltages and currents; Power supply rejection ratio, Slew Rate and concept of Virtual Ground, Summing and Difference Amplifiers, Differentiator and Integrator, RC phase shift oscillator.</p>	8
<p><u>Module-4</u> Logic Gates and Boolean algebra: Introduction to Boolean Algebra and Boolean operators, Symbolic representation, Boolean algebraic function and Truth table of different Digital logic Gates (AND, OR, NOT, NAND, NOR, EXOR, EX-NOR); Realization of Basic logic gates using universal gates, Adder, Subtractor, adder/subtractor.</p>	8
<p><u>Module-5</u> Electronic communication: Introduction to electronic communication system, Electromagnetic Communication spectrum band and applications, Elements of Electronic Communication System; Merits and demerits of analog and digital communication, Modes of communication; Signal radiation and propagation; Need for modulation; Introduction to Amplitude modulation and Angle modulation.</p>	10

Text Books:

1. Millman J., Halkias C.C., Parikh Chetan, “Integrated Electronics: Analog and Digital Circuits and Systems”, Tata McGraw-Hill, 2/e.
2. Mano M.M., “Digital Logic and Computer Design”, Pearson Education, Inc, Thirteenth Impression, 2011.
3. Singal T. L., “Analog and Digital Communications”, Tata McGraw-Hill, 2/e.
4. Haykin S., Moher M., “Introduction to Analog & Digital Communications”, Wiley India Pvt. Ltd., 2/e.

Reference Book:

1. Boylstead R.L., Nashelsky L., “Electronic Devices and Circuit Theory”, Pearson Education, Inc, 10/e.

Gaps in the syllabus (to meet Industry/Profession requirements): NA**POs met through Gaps in the Syllabus: 3, 11, 12****Topics beyond syllabus/Advanced topics/Design: NA****POs met through Topics beyond syllabus/Advanced topics/Design: 2, 3, 11, 12****Course Outcome (CO) Attainment Assessment Tools & Evaluation Procedure: Direct Assessment**

Assessment Tool	% Contribution during CO Assessment
First Quiz	10
Mid Semester Examination	25
Second Quiz	10
Teacher's Assessment	5
End Semester Examination	50

Indirect Assessment

1. Student Feedback on Faculty
2. Student Feedback on Course Outcome

Mapping of Course Outcomes onto Program Outcomes:

Course Outcome	Program Outcomes (POs)												Program Specific Outcomes (PSOs)		
	1	2	3	4	5	6	7	8	9	10	11	12	13	14	15
CO1	3	3	1	2	3	1	1	2	2	3	2	2	3	3	1
CO2	3	3	1	2	3	1	1	2	2	3	2	2	3	3	1
CO3	3	3	1	2	3	1	1	2	2	3	2	2	3	3	1
CO4	3	3	1	2	3	1	1	2	2	3	2	2	3	3	1
CO5	3	3	1	2	3	1	1	2	2	3	2	2	3	3	1

Correlation Levels 1, 2 or 3 as defined below:

1: Slight (Low) 2: Moderate (Medium) 3: Substantial (High)

Mapping Between COs and Course Delivery (CD) methods

CD Code	Course Delivery Methods	Course Outcome	Course Delivery Method Used
CD1	Lecture by use of Boards/LCD Projectors	CO1	CD1, CD2, CD3, CD8
CD2	Quizzes	CO2	CD1, CD2, CD3, CD8
CD3	Assignments/Seminars	CO3	CD1, CD2, CD3, CD8
CD4	Mini Projects/Projects	CO4	CD1, CD2, CD3, CD8
CD5	Laboratory Experiments/Teaching Aids	CO5	CD1, CD2, CD3, CD8
CD6	Industrial/Guest Lectures		
CD7	Industrial Visits/In-plant Training		
CD8	Self- learning such as use of NPTEL Materials and Internets		
CD9	Simulation		

COURSE INFORMATION SHEET
Electronics & Communication Lab

Course code: EC102

Course title: Electronics & Communication Lab

Pre-requisite(s):

Co- requisite(s):

Credits: L: 0 T: 0 P: 3 C: 1.5 **Class**
schedule per week: 03 Class: B. Tech. Semester
/ Level: 01/01 Branch: ALL B. Tech.

Name of Teacher: ALL

Course Objectives:

This course enables the students:

1.	To demonstrate the measurement of voltage, frequency using CRO
2.	To explain PN junction characteristics and its applications.
3.	To understand the frequency response of BJT amplifier and OPAMP.
4.	To Realize logic gates and implement simple Boolean expression.
5.	To explain the Amplitude Modulation and Frequency Modulation

Course Outcomes:

After the completion of this course, students will be able to:

CO1	Make use of CRO for measuring different parameters
CO2	Appraise PN junction characteristics and its applications.
CO3	Experiment with Diodes, BJT and OPAMP
CO4	Design specified circuit using given electronic components/ICs/logic gates.
CO5	Demonstrate the working of Amplitude Modulation and Frequency Modulation

Syllabus

List of Compulsory experiments:

1. **Name of the Experiment: MEASUREMENTS USING CRO**

AIM-1: To understand the Measurement of voltage, time period and frequency of different signals on CRO.

AIM-2: To measure the frequency and phase of two different signals using Lissajous pattern.

2. **Name of the Experiment: PN JUNCTION CHARACTERISTICS**

AIM-1: To determine the forward bias V-I characteristics of PN junction diode and finding its forward cut-in voltage.

AIM-2: To determine the reverse bias V-I characteristics of PN junction diode and finding its reverse breakdown voltage.

3. **Name of the Experiment: ZENER DIODE**

AIM-1: To design a basic voltage regulator circuit using Zener diode.

AIM-2: To determine the reverse bias V-I characteristics of Zener diode and finding its reverse breakdown voltage.

4. **Name of the Experiment: RECTIFIERS WITH FILTERS.**

AIM-1: To understand the basic operation principle of Half-wave rectifier circuit and measurement of rectification efficiency and ripple factor with and without C-Filter.

AIM-2: To understand the basic operation principle of Full-wave rectifier circuit and measurement of rectification efficiency and ripple factor with and without C-Filter.

AIM-3: Simulate Half wave, Full wave and Bridge rectifier circuits and determine the following in each case

i) ripple factor ii) ratio of rectification iii) TUF.

AIM-4: Simulate Half wave rectifier circuit and observe the effect on rectification at high frequency.

5. **Name of the Experiment: CE TRANSISTOR AMPLIFIER**

AIM-1: To understand the basic operation principle of CE transistor amplifier circuit and finding its frequency response.

AIM-2: To determine the gain bandwidth product of CE transistor amplifier from its frequency response.

AIM-3: To determine the minimum input voltage for which the CE transistor amplifier saturates for given gain.

6. **Name of the Experiment: FIELD EFFECT TRANSISTOR**

AIM-1: To determine the output and transfer characteristics of JFET.

AIM-2: To measure the voltage gain of JFET.

7. **Name of the Experiment: RC OSCILLATOR.**

AIM-1: To design a RC phase shift oscillator using IC-741 Op-Amp.

AIM-2: To measure its frequency of oscillation and finding the percentage of error in Comparison with the ideal one.

8. **Name of the Experiment: OPERATIONAL AMPLIFIERS**

AIM-1: To design the Inverting and Non-inverting amplifier using IC 741 OP-AMP.

AIM-2: To find its frequency response and calculate the gain bandwidth product.

AIM-3: To determine the minimum input voltage for which the inverting and non-inverting amplifier saturates for the gains 100 and 101 respectively.

9. Name of the Experiment: LOGIC GATES

AIM-1: To understand basic Boolean logic functions (NOT, AND, OR).

AIM-2: To realize the basic logic gates (AND, OR, NOT) using NAND Gate (IC-7400).

10. Name of the Experiment: BOOLEAN FUNCTION

AIM-1: To understand AND Gate IC (IC 7408) and OR Gate IC (IC 7432)

AIM-2: To implement of the Boolean expression $F = (A.B.C + D.E)$ using AND Gate (IC 7408) and OR Gate (IC 7432).

11. Name of the Experiment: AMPLITUDE MODULATION

AIM-1: To analyze the Amplitude modulation for three different cases (under modulation, critical modulation and over modulation) using standard setup.

AIM-2: To determine the percentage of error between the ideal and actual observations.

12. Name of the Experiment: FREQUENCY MODULATION

AIM-1: To analyze the Frequency modulation using standard setup.

AIM-2: To determine the value of frequency deviation from the observation.

Text Books:

1. Millman J., Halkias C.C., Parikh Chetan, "Integrated Electronics: Analog and Digital Circuits and Systems", Tata McGraw-Hill, 2/e.
2. Mano M.M., "Digital Logic and Computer Design", Pearson Education, Inc, Thirteenth Impression, 2011.
3. Singal T. L., "Analog and Digital Communications", Tata McGraw-Hill, 2/e.
4. Haykin S., Moher M., "Introduction to Analog & Digital Communications", Wiley India Pvt. Ltd., 2/e.

Reference Book:

1. Boylstead R.L., Nashelsky L., "Electronic Devices and Circuit Theory", Pearson Education, Inc, 10/e.

Gaps in the syllabus (to meet Industry/Profession requirements): NA

POs met through Gaps in the Syllabus: N/A.

Topics beyond syllabus/Advanced topics/Design: N/A

POs met through Topics beyond syllabus/Advanced topics/Design: N/A

Course Outcome (CO) Attainment Assessment tools & Evaluation procedure

Direct Assessment

Assessment Tool	% Contribution during CO Assessment
Progressive Evaluation	(60)
Attendance Marks	12
Day-to-day performance Marks	06
Lab Viva marks	20
Lab file Marks	12
Lab Quiz-I Marks	10
End SEM Evaluation	(40)
Lab Quiz-II Marks	10
Lab performance Marks	30

Indirect Assessment –

1. Student Feedback on Faculty
2. Student Feedback on Course Outcome

Mapping of Course Outcomes onto Program Outcomes

Course Outcome	Program Outcomes (POs)												Program Specific Outcomes (PSOs)		
	1	2	3	4	5	6	7	8	9	10	11	12	1	2	3
CO1	3	3	1	2	3	1	2	1	2	2	2	2	2	2	1
CO2	3	3	1	2	3	1	2	1	2	2	2	2	2	2	1
CO3	3	2	1	2	3	1	2	1	2	2	2	2	2	2	1
CO4	3	3	1	2	3	1	2	1	2	2	2	2	2	2	1
CO5	3	2	1	2	3	1	2	1	2	2	2	2	2	2	1

Correlation Levels 1, 2 or 3 as defined below:

1: Slight (Low) 2: Moderate (Medium) 3: Substantial (High)

Mapping Between COs and Course Delivery (CD) methods:

CD Code	Course Delivery Methods	Course Outcome	Course Delivery Method Used
CD1	Lecture by use of Boards/LCD Projectors	CO1	CD1, CD5, CD9
CD2	Tutorials/Assignments	CO2	CD1, CD5, CD9
CD3	Seminars/ Quiz (s)	CO3	CD1, CD5, CD9
CD4	Mini Projects/Projects	CO4	CD1, CD5, CD9
CD5	Laboratory Experiments/Teaching Aids	CO5	CD1, CD5, CD9
CD6	Industrial/Guest Lectures		
CD7	Industrial Visits/In-plant Training		
CD8	Self- learning such as use of NPTEL Materials and Internets		
CD9	Simulation		

COURSE INFORMATION SHEET
Electronic Devices

Course code: EC201

Course title: Electronic Devices

Pre-requisite(s): EC101 Basics of Electronics & Communication Engineering Co-requisite(s):

Credits: L: 3 T: 0 P: 0 C: 3 Class schedule

per week: 03 Class: B. Tech.

Semester / Level: III/02

Branch: ECE

Name of Teacher:

Course Objectives

This course envisions to impact to students to:

1.	Understand Atoms, Electrons, Energy Bands and Charge Carriers in Semiconductors.
2.	Grasp the impact of Excess Carriers in Semiconductors, Optical Absorption, Carrier Lifetime, Photoconductivity and Diffusion of Carriers and apply the obtained knowledge.
3.	Appraise and analyse the characteristics of PN Junction and Junction Diodes.
4.	Evaluate the characteristics of Bipolar Junction Transistor (BJT).
5.	Comprehend the characteristics of Field-Effect Transistors and create their structures.

Course Outcomes

After the completion of this course, a student will be able to:

CO1	Describe and illustrate the Atoms, Electrons, Energy Bands and Charge Carriers in Semiconductors.
CO2	Sketch and explain the Carrier Transport Phenomena in semiconductor.
CO3	Illustrate with the sketch of the structure of PN Junction and Junction Diodes diagram their characteristics and analyse them.
CO4	Appraise the principle of operation BJTs, schematize their characteristics, assess and summarize their features.
CO5	Schematize the structure and design Field Effect Transistors. Schematize their characteristics and prepare an inference.

SYLLABUS

MODULE	(NO. OF LECTURE HOURS)
<p>Module – I Atoms, Electrons, Energy Bands and Charge Carriers in Semiconductors: Quantum Mechanics, Bonding Forces and Energy Bands in Solids, Direct and Indirect Semiconductors, LED, Variation of Energy Bands with Alloy Composition, Effective Mass, Electrons and Holes in Quantum Wells, Gunn Diode, Temperature Dependence of Carrier Concentrations, Conductivity and Mobility, High-Field Effects, The Hall Effect.</p>	8
<p>Module – II Excess Carriers in Semiconductors: Optical Absorption, Luminescence, Carrier Lifetime and Photoconductivity, Solar Cells; Diffusion of Carriers: Diffusion Processes, Diffusion and Drift of Carriers; Built-in Fields, Diffusion and Recombination; The Continuity Equation, Steady State Carrier Injection; Diffusion Length, The Haynes–Shockley Experiment.</p>	8
<p>Module – III PN Junction and Junction Diodes: Charge at Junction, Contact Potential, Capacitance of p-n Junctions, Reverse-Bias Breakdown, Zener diode, Varactor Diode, Effects of Contact Potential on Carrier Injection, Recombination and Generation in Transition Region, Metal–Semiconductor Junctions, PIN diodes, Step Recovery Diodes, IMPATT diodes, Tunnel Diode.</p>	8
<p>Module – IV Bipolar Junction Transistor (BJT): Fundamentals of BJT Operation, Amplification with BJTs, Minority Carrier Distributions and Terminal Currents, Drift in the Base Region, Base Narrowing, Avalanche Breakdown, Gummel–Poon Model, Kirk Effect; Frequency Limitations of Transistors, High-Frequency Transistors, Heterojunction Bipolar Transistors.</p>	8
<p>Module – V Field-Effect Transistors: Junction FET, GaAs MESFET, High Electron Mobility Transistor (HEMT); Metal–Insulator–Semiconductor FET, MOSFET: Output Characteristics, Transfer Characteristics, Mobility Models, Short Channel MOSFET I–V Characteristics, Threshold Voltage Expression, Substrate Bias Effects, Subthreshold Characteristics, Equivalent Circuit for the MOSFET, CMOS processes.</p>	8

Textbooks:

1. G. Streetman, and S. K. Banerjee, "Solid State Electronic Devices," 7th edition, Pearson, 2014.
2. J. P. Colinge, C. A. Colinge, "Physics of Semiconductor Devices", Springer Science & Business Media, 2007.

Reference books:

1. SM Sze, Kwok K. Ng, "Physics of Semiconductor Devices", 3/e, Wiley-Interscience, 2006.
2. Donald A. Neamen, Dhruves Biswas "Semiconductor Physics and Devices", 4/e, McGrawHill Education, 2012.

Gaps in the syllabus (to meet Industry/Profession requirements):

1. Hands-on-practical for Device fabrication.

POs met through Gaps in the Syllabus:

10

Topics beyond syllabus/Advanced topics/Design:

1. N/A

POs met through Topics beyond syllabus/Advanced topics/Design:

10

Course Outcome (CO) Attainment Assessment Tools and Evaluation Procedure Direct Assessment

Assessment Tool	% Contribution during CO Assessment
First Quiz	10
Mid Semester Examination	25
Second Quiz	10
Teacher's Assessment	5
End Semester Examination	50

Indirect Assessment

1. Students' Feedback on Course Outcome.

Mapping between Course Outcomes and Program Outcomes

Course Outcome	Program Outcomes (POs)												Program Specific Outcomes (PSOs)		
	1	2	3	4	5	6	7	8	9	10	11	12	13	14	15
CO1	3	3	2	3	3	1	1			3		3	3	2	1
CO2	3	3	2	3	3	2	1			3		3	3	2	1
CO3	3	3	2	3	3	2	1			3		3	3	2	1
CO4	3	3	2	3	3	3	1			3		3	3	2	1
CO5	3	3	2	3	3	3	1			3		3	3	2	1

Correlation Levels 1, 2 or 3 as defined below:

1: Slight (Low) 2: Moderate (Medium) 3: Substantial (High)

Mapping Between COs and Course Delivery (CD) methods

CD Code	Course Delivery Methods	Course Outcome	Course Delivery Method Used
CD1	Lecture by use of Boards/LCD Projectors	CO1	CD1, CD7, CD 8
CD2	Tutorials/Assignments	CO2	CD1 and CD9
CD3	Seminars	CO3	CD1, CD2 and CD3
CD4	Mini Projects/Projects	CO4	CD1 and CD2
CD5	Laboratory Experiments/Teaching Aids	CO5	CD1 and CD2
CD6	Industrial/Guest Lectures		
CD7	Industrial Visits/In-plant Training		
CD8	Self- learning such as use of NPTEL Materials and Internets		
CD9	Simulation		

COURSE INFORMATION SHEET

Electronics Device Lab

Course code: EC202

Course title: Electronic Devices Lab

Pre-requisite(s): EC101 Basics of Electronics & Communication Engineering,

Co- requisite(s): EC201 Electronic Devices

Credits: L: 0 T: 0 P: 3 C: 1.5 Class

periods per week: 03 **Class:** B. Tech.

Semester / Level: III/02

Branch: ECE Name of

Teacher:

Course Objectives

This course enables the students to:

1.	understand the material and electrical parameters of intrinsic and extrinsic semiconductor materials.
2.	understand the basic characteristics of MOS transistor, Tunnel diode and solar cell
3.	apply their understanding to use advance design TCAD tool to obtain the material and electrical parameters of intrinsic and extrinsic semiconductor materials.
4.	apply their understanding to use advance design TCAD tool to describe basic characteristics of BJT and MOS transistors and inverter.
5.	apply their understanding to use advance design TCAD tool to analyze characteristics of inverter.

Course Outcomes

After the completion of this course, students will be able to:

CO1	analyse the material and electrical parameters of intrinsic and extrinsic semiconductor materials.
CO2	measure the basic characteristics of Tunnel diode and solar cell
CO3	measure the basic characteristics of MOS transistors
CO4	use the advance design tool TCAD to evaluate the material and electrical parameters of intrinsic and extrinsic semiconductor materials.
CO5	use the advance design tool TCAD to construct BJT, MOS transistors and inverter and evaluate their characteristics.

SYLLABUS

Lab is the application of the theory (i.e., hands-on experiments related to the course contents). Therefore, **EC201 Electronic Devices** is the syllabus for the **EC202 Electronic Devices Lab**. Following experiments are the guidelines for the students. However, the questions for exams are not limited to this experiment list.

List of Compulsory experiments:

1. Identify the type of semiconductor material and calculate the mobility, conductivity and carrier concentration of majority carriers using Hall Effect experiment.
2. Calculate the bandgap of semiconductor materials.
3. Measure the I-V characteristics of an NPN transistor in Common Emitter (CE) mode.
4. Measure the I_d - V_d and I_d - V_g characteristics of an enhancement mode nMOSFET and a depletion mode nMOSFET.
5. Measure the I-V characteristics of a Tunnel & Schottky diode.
6. Evaluate the I-V characteristics of an illuminated pn junction (solar cell).
7. Evaluate the parameters (sheet resistance, mobility, saturation velocity, etc.) of the intrinsic and the extrinsic semiconductor materials using TCAD tool.
8. Construct a silicon pn junction diode and evaluate I-V characteristics curve using TCAD tool.
9. Develop an NPN Transistor and measure the I-V characteristics curves in Common Emitter (CE) mode using TCAD tool.
10. Develop an enhancement mode nMOSFET and measure I_d - V_d and I_d - V_g characteristics using TCAD tool.
11. Construct an enhancement mode pMOSFET and measure I_d - V_d and I_d - V_g characteristics using TCAD tool.
12. Design a CMOS inverter and asses the DC/transient characteristics using TCAD tool.

List of Optional experiments:

1. Calculate the mobility and the diffusion coefficient of minority carriers using Haynes Shockley experiment.
2. Evaluate the I-V characteristics of an NPN transistor in Common Collector (CC) mode.
3. Measure the I-V characteristics of an NPN transistor in Common Base (CB) mode.
4. Evaluate the I-V characteristics of a PNP transistor in Common Emitter (CE) mode.
5. Measure the I-V characteristics of a PNP transistor in Common Collector (CC) mode.
6. Evaluate the I-V characteristics of a PNP transistor in Common Base (CB) mode.

7. Demonstrate the I-V characteristics of forward and reverse biased Silicon and Germanium pn-junction diode.
8. Demonstrate the I-V characteristics of forward and reverse biased Zener diode. Study the breakdown characteristics of the Zener diode.
9. Construct a PNP Transistor and evaluate the I-V characteristics curves in Common Emitter (CE) mode using TCAD tool.
10. Demonstrate diode application as a rectifier using TCAD tool
11. Construct a depletion mode nMOSFET and evaluate Id-Vd and Id-Vg characteristics using TCAD tool.
12. Construct a depletion mode pMOSFET and evaluate Id-Vd and Id-Vg characteristics using TCAD tool.

Books recommended:

Textbooks:

1. G. Streetman, and S. K. Banerjee, "Solid State Electronic Devices," 7th edition, Pearson, 2014.
2. J. P. Colinge, C. A. Colinge, "Physics of Semiconductor Devices", Springer Science & Business Media, 2007.
3. J. Rabaey, A. Chandrakasan, B. Nikolic, "Digital Integrated Circuits: A Design Perspective", 2nd ed., Prentice Hall, 2003.

Reference books:

1. SM Sze, Kwok K. Ng, "Physics of Semiconductor Devices", 3/e, Wiley-Interscience, 2006.
2. Donald A. Neamen, Dhrubes Biswas "Semiconductor Physics and Devices", 4/e, McGraw-Hill Education, 2012.
3. Cogenda Visual TCAD tool user manual.

Gaps in the syllabus (to meet Industry/Profession requirements):

1. Hands-on-practical for Device fabrication.

POs met through Gaps in the Syllabus:

10

Topics beyond syllabus/Advanced topics/Design:

N/A

POs met through Topics beyond syllabus/Advanced topics/Design:

10

Course Outcome (CO) Attainment Assessment Tools and Evaluation Procedure

Direct Assessment

Assessment Tools	% Contribution during CO Assessment
Continuous Internal Assessment	60
Semester End Examination	40

Continuous Internal Assessment	% Distribution
Day to day performance & Lab files	30
Quiz(zes)	10
Viva	20

Semester End Examination	% Distribution
Examination Experiment Performance	30
Quiz	10

Indirect Assessment

1. Students' Feedback on Course Outcome.

Mapping of Course Outcomes onto Program Outcomes

Course Outcome	Program Outcomes (POs)												Program Specific Outcomes (PSOs)		
	1	2	3	4	5	6	7	8	9	10	11	12	13	14	15
CO1	3	3	3	3	3	1	1	1		3		3	3	2	2
CO2	3	3	3	3	3	1	1	1		3		3	3	2	2
CO3	3	3	3	3	3	1	1	1		3		3	3	2	1
CO4	3	3	3	3	3	1	1	1		3		3	3	2	1
CO5	3	3	3	3	3	1	1	1		3		3	3	2	1

Correlation Levels 1, 2 or 3 as defined below:

- 1: Slight (Low) 2: Moderate (Medium) 3: Substantial (High)

Course Delivery Methods

CD1	Lecture by use of boards/LCD projectors/OHP projectors
CD2	Assignments
CD3	Laboratory experiments/Teaching aids/Seminars
CD4	Mini Projects
CD5	Industrial visits/in-plant training
CD6	Self- learning such as use of NPTEL materials and internets
CD7	Simulation

Mapping between Course Outcomes and Course Delivery Method

Course Outcomes	Course Delivery Method
CO1	CD1, CD3, CD6, CD7
CO2	CD1, CD3, CD6, CD7
CO3	CD1, CD3, CD6, CD7
CO4	CD1, CD3, CD6, CD7
CO5	CD1, CD3, CD6, CD7

COURSE INFORMATION SHEET

Digital System Design

Course code: EC203 R1

Course title: Digital System Design

Pre-requisite(s): EC101 Basics of Electronics & Communication Engineering

Co- requisite(s):

Credits: L: 3 T:0 P:0 C:3

Class schedule per week: 3x1

Class: B. Tech

Semester / Level: III/02

Branch: ECE

Name of Teacher:

Course Objectives

This course enables the students to:

1.	Understand the basics of digital electronics.
2.	Apply the knowledge of digital electronics to construct various digital circuits.
3.	Analyze the characteristics and explain the outputs of digital circuits.
4.	Evaluate and asses the application of the digital circuits.
5.	To realize various Multivibrators using transistors, op-amp and other discrete components.

Course Outcomes

After the completion of this course, students will be able to:

CO1	Explain the concept of digital electronics.
CO2	Apply the knowledge to produce digital electronics circuits.
CO3	Analyse and categorize digital circuits.
CO4	Justify the uses of different digital circuits.
CO5	Demonstrate the Bistable, Monostable and Astable Multivibrators using discrete components.

SYLLABUS

MODULE	(NO. OF LECTURE HOURS)
<p>Module – I Basics of Digital Electronics: Review of number systems and codes used in digital system. Review of arithmetic used in digital system. Logic gates associated postulates and laws. Logic Families: TTL, ECL, and CMOS Logic Circuits, Logic levels, voltages and currents, fan-in, fan-out, speed, power dissipation. Comparison of logic families. Introduction to VHDL and Verilog, VHDL Models</p>	8
<p>Module – II Simplification of Boolean functions: Boolean Algebra, Basic theorems and Properties, De Morgan’s theorem, Canonical & Standard forms, Simplification of a Boolean function using Karnaugh map, POS & SOP simplification, Prime implicant, NAND and NOR implementation.</p>	8
<p>Module – III Design of Combinational Circuits: Analysis and design procedure, Parity Generators and Checkers, Adders, Subtractors, Look ahead carry, Adder, 4-bit BCD adder/subtractor, Magnitude comparator, Decoders, Encoders, Multiplexers, Demultiplexers, Design of 1-bit ALU for basic logic and arithmetic operations.</p>	8
<p>Module – IV Design of Sequential Circuits and Memories: Basic Latch, Flip-Flops (SR, D, JK, T and Master-Slave), Triggering of Flip Flops, Synchronous and asynchronous counters, Registers, Shift Registers. Design of sequential circuit using state diagrams.</p>	8
<p>Module – V Memories and Programmable Logic design, Types of memories, Memory Expansion and its decoding, Programmable Logic Arrays (PLA), Programmable Array Logic (PAL). Switching Circuits and Multivibrators: Astable, Monostable and Bistable Multivibrators using BJTs, Schmitt trigger circuit, Multivibrators using op-amp and IC 555 timer.</p>	8

Books recommended:

Textbooks:

1. “Digital Design”, Morris Mano and Michael D. Ciletti ,5th edition PHI
2. “Digital System Design using VHDL”, Charles H Roth, Thomson Learning

Reference books:

1. Digital computer Electronics AP Malvino, 3rd Edition Mc Graw Hill

Gaps in the syllabus (to meet Industry/Profession requirements): N/A

POs met through Gaps in the Syllabus: N/A

Topics beyond syllabus/Advanced topics/Design: Computer System Architecture

POs met through Topics beyond syllabus/Advanced topics/Design: N/A

Course Outcome (CO) Attainment Assessment Tools & Evaluation Procedure

Direct Assessment

Assessment Tool	% Contribution during CO Assessment
First Quiz	10
Mid Semester Examination	25
Second Quiz	10
Teacher's Assessment	5
End Semester Examination	50

Indirect Assessment

1. Students' Feedback on Course Outcome.

Mapping of Course Outcomes onto Program Outcomes

Course Outcome	Program Outcomes (POs)												Program Specific Outcomes (PSOs)		
	1	2	3	4	5	6	7	8	9	10	11	12	13	14	15
CO1	3	3	2	3	3	1	1			3		3	3	3	2
CO2	3	3	2	3	3	3	2			3		3	3	3	2
CO3	3	3	2	3	3	3	2			3		3	3	3	2
CO4	3	3	2	3	3	2	2			3		3	3	3	2
CO5	3	3	2	3	3	2	2			3		3	3	3	2

Correlation Levels 1, 2 or 3 as defined below:

- 1: Slight (Low) 2: Moderate (Medium) 3: Substantial (High)

Mapping Between COs and Course Delivery (CD) methods

CD Code	Course Delivery Methods	Course Outcome	Course Delivery Method Used
CD1	Lecture by use of Boards/LCD Projectors	CO1	CD1, CD2, CD5, CD 8
CD2	Tutorials/Assignments	CO2	CD1, CD2, CD5, CD 8

CD3	Seminars	CO3	CD1, CD2, CD5, CD 8
CD4	Mini Projects/Projects	CO4	CD1, CD2, CD5, CD 8
CD5	Laboratory Experiments/Teaching Aids	CO5	CD1, CD2, CD5, CD 8
CD6	Industrial/Guest Lectures		
CD7	Industrial Visits/In-plant Training		
CD8	Self- learning such as use of NPTEL Materials and Internets		
CD9	Simulation		

COURSE INFORMATION SHEET
Digital System design Lab

Course code: EC204 R1

Course title: Digital System design Lab

Pre-requisite(s): EC101 Basics of Electronics & Communication Engineering

Co- requisite(s):

Credits: L:0 T:0 P:3 C:1.5

Class schedule per week: 03

Class: B. Tech

Semester / Level: III/ 02

Branch: ECE

Name of Teacher:

Course Objectives

This course enables the students to:

1.	Understand the basics of logic gates, input, output, power supply, and gates IC's.
2.	Apply the knowledge of digital electronics to construct combinational and sequential circuits.
3.	Analyze controlled digital circuits with different Boolean function.
4.	Evaluate combinational/sequential circuits and memories.
5.	Translate real-world problems into digital logic formulations using VHDL.

Course Outcomes

After the completion of this course, students will be able to:

CO1	Describe the knowledge of basic logic gates and their design using universal gates.
CO2	Demonstrate the working of combinational and sequential circuits.
CO3	Integrate and experiment with controlled digital circuits and design of multivibrator circuits.
CO4	Appraise combinational/ sequential circuits and memories.
CO5	Schematize, simulate, and implement combinational and sequential circuits to solve real-world problems using VHDL systems.

SYLLABUS

List of experiments:

- 1. Name of the Experiment: CMOS INVERTER**
AIM1: Design and implement AND OR and NOT gate using CMOS Inverter.
- 2. Name of the Experiment: EX-OR GATE**
AIM1: To study and verify the truth table of NAND and EX-OR gate using IC 7400.
- 3. Name of the Experiment: SEVEN SEGMENT DISPLAY**
AIM1: Design and implement SEVEN segment display unit.
- 4. Name of the Experiment: ADDER CIRCUITS**

- AIM1: Design and verify half adder and full Adder circuits using gates and IC 7483.
5. **Name of the Experiment: DECODER CIRCUITS & ENCODER CIRCUITS**
 AIM1: Design and implement a 3:8 Decoder.
 AIM2: Design and implement 8:3 priority encoder.
 6. **Name of the Experiment: MAGNITUDE COMPARATOR**
 AIM1: Design a 4-bit magnitude comparator using combinational circuits.
 7. **Name of the Experiment: MUX & DEMUX**
 AIM1: Design and implement 8:1 multiplexer and 1:4 demultiplexer.
 8. **Name of the Experiment: ARITHMETIC AND LOGICAL UNIT**
 AIM1: Design ALU with functions of ADD, SUB, INVERT, OR, AND, XOR, INC, DEC, and CMP.
 9. **Name of the Experiment: DECADE COUNTER**
 AIM1: Design and verify the Decade Counter.
 10. **Name of the Experiment: DIODE ROM**
 AIM1: Design a ROM (8X4) using a decoder, gates, and diodes.
 11. **Name of the Experiment: UP/DOWN COUNTER**
 12. **Construction of astable and monostable multivibrators using IC555 timer and plotting of the output waveforms.**
 AIM1: Observe the waveforms of astable and monostable multivibrators
 AIM2: Verify different states and find the frequency.

Implement all the relevant experiments using VHDL platform and verify.

Books recommended:

Textbooks:

1. "Digital Design", Morris Mano and Michael D. Ciletti ,5th edition PHI
2. "Digital System Design using VHDL", Charles H Roth, Thomson Learning

Reference books:

2. Digital computer Electronics AP Malvino, 3rd Edition Mc Graw Hill

Gaps in the syllabus (to meet Industry/Profession requirements): N/A

POs met through Gaps in the Syllabus: N/A

Topics beyond syllabus/Advanced topics/Design: N/A

POs met through Topics beyond syllabus/Advanced topics/Design: N/A

Course Outcome (CO) Attainment Assessment tools & Evaluation procedure

Direct Assessment

Assessment Tool	% Contribution during CO Assessment
Progressive Evaluation	(60)

Attendance Marks	12
Day-to-day performance Marks	06
Lab Viva marks	20
Lab file Marks	12
Lab Quiz-I Marks	10
End SEM Evaluation	(40)
Lab Quiz-II Marks	10
Lab performance Marks	30

Indirect Assessment –

1. Student Feedback on Course Outcome

Mapping of Course Outcomes onto Program Outcomes

Course Outcome	Program Outcomes (POs)												Program Specific Outcomes (PSOs)		
	1	2	3	4	5	6	7	8	9	10	11	12	1	2	3
CO1	3	3	3	3	3	1	1	1		3		3	2	2	1
CO2	3	3	3	3	3	1	1	1		3		3	2	2	1
CO3	3	3	3	3	3	1	1	1		3		3	2	2	1
CO4	3	3	3	3	3	1	1	1		3		3	2	2	1
CO5	3	3	3	3	3	1	1	1		3		3	2	2	1

Correlation Levels 1, 2 or 3 as defined below:

- 1: Slight (Low) 2: Moderate (Medium) 3: Substantial (High)

Mapping Between COs and Course Delivery (CD) methods:

CD Code	Course Delivery Methods	Course Outcome	Course Delivery Method Used
CD1	Lecture by use of Boards/LCD Projectors	CO1	CD1, CD5, CD9
CD2	Tutorials/Assignments	CO2	CD1, CD5, CD9
CD3	Seminars/ Quiz (s)	CO3	CD1, CD5, CD9
CD4	Mini Projects/Projects	CO4	CD1, CD5, CD9
CD5	Laboratory Experiments/Teaching Aids	CO5	CD1, CD5, CD9
CD6	Industrial/Guest Lectures		
CD7	Industrial Visits/In-plant Training		
CD8	Self- learning such as use of NPTEL Materials and Internets		
CD9	Simulation		

COURSE INFORMATION SHEET

Signals and Systems

Course code: EC205

Course title: Signals and Systems

Pre-requisite(s): EC101 Basics of Electronics & Communication Engineering **Co-requisite(s):**

Credits: L: 3 T: 0 P: 0 C: 3 **Class**

schedule per week: 03 **Class:** B. Tech.

Semester / Level: III/02

Branch: ECE

Name of Teacher:

Course Objectives:

This course enables the students:

1.	To understand the fundamental characteristics of signals and systems.
2.	To understand the concepts of different transforms for signal and system.
3.	To understand signals and systems in terms of both the time and transform domains.
4.	To develop the mathematical skills to solve problems involving convolution, filtering, modulation, and sampling.
5.	To understand the response of LTI systems using Transform theory.

Course Outcomes:

After the completion of this course, a student will be able to

CO1	define signal, systems and its importance in life.
CO2	represent the signal in the time domain as well as in Frequency domain and find the response of the system.
CO3	explain the transform theory and its importance to analyze signal and system.
CO4	identify system properties based on impulse response and Fourier analysis.
CO5	explain Sampling theorem and its importance in discrete time systems representation.

SYLLABUS

MODULE	(NO. OF LECTURE HOURS)
<p>Module – I INTRODUCTION TO SIGNALS AND SYSTEMS: Signals and systems as seen in everyday life and in various branches of engineering and science, Signal properties: periodicity, absolute integrability, determinism, and stochastic character. Some special signals of importance: the unit step, the unit impulse, the sinusoid, the complex exponential, some special time-limited signals; continuous and discrete time signals, continuous and discrete amplitude signals. System properties: linearity: additivity and homogeneity, shift-invariance, causality, stability, realizability.</p>	<p>9</p>
<p>Module – II BEHAVIOR OF CONTINUOUS AND DISCRETE-TIME LTI SYSTEMS: Impulse response and step response, convolution, input-output behavior with aperiodic convergent inputs, cascade interconnections. Characterization of causality and stability of LTI systems. System representation through differential equations and difference equations. State-space Representation of systems. StateSpace Analysis, Multi-input, multi-output representation. State Transition Matrix and its Role. Periodic inputs to an LTI system, the notion of frequency response and its relation to the impulse response.</p>	<p>9</p>
<p>Module – III FOURIER AND LAPLACE TRANSFORMS: Fourier series representation of periodic signals, Waveform Symmetries, Calculation of Fourier Coefficients. Fourier Transform, convolution/multiplication and their effect in the frequency domain, magnitude and phase response, Fourier domain duality, Laplace Transform for continuous-time signals and systems, Transfer/system functions, poles and zeros of system functions and signals, Laplace domain analysis, the solution to differential equations and system behavior.</p>	<p>8</p>
<p>Module – IV Z-TRANSFORM, DTFT, AND DFT: Z-transform, Region of convergence and its properties, Inverse Z transform, properties of ZT, The Discrete-Time Fourier Transform (DTFT) and the Discrete Fourier Transform (DFT), Parseval's Theorem., Properties of DTFT and DFT, convolution property, multiplication property, Duality, Systems Characterized by Linear Constant Coefficient Difference Equation, The z-Transform for discrete time signals and systems, system functions, poles and zeros of systems and sequences, z-domain analysis.</p>	<p>7</p>
<p>Module – V SAMPLING AND RECONSTRUCTION: The Sampling Theorem and its implications. Spectra of sampled signals. Reconstruction: ideal interpolator, zero-order hold, first-order hold. Aliasing and its effects. The relation between continuous and discrete time systems. Applications of signal and system theory: modulation for communication, filtering, feedback control systems.</p>	<p>7</p>

Books recommended:**Textbooks:**

1. A. V. Oppenheim, A. S. Willsky and S. H. Nawab, "Signals and systems", Prentice Hall India, 1997.
2. S. Haykin and B. V. Veen, "Signals and Systems", John Wiley and Sons, 2007.

Reference books:

1. John G. Proakis, Dimitris G. Manolakis, Digital Signal Processing, Principles, Algorithms, and Applications.
2. Robert A. Gable, Richard A. Roberts, Signals & Linear Systems
3. R.F. Ziemer, W.H. Tranter and D.R. Fannin, "Signals and Systems - Continuous and Discrete", 4th edition, Prentice Hall, 1998.
4. Papoulis, "Circuits and Systems: A Modern Approach", HRW, 1980.
5. Douglas K. Lindner, "Introduction to Signals and Systems", McGraw Hill International Edition: c1999.
6. B.P. Lathi, "Signal Processing and Linear Systems", Oxford University Press, c1998.

Gaps in the Syllabus (to meet Industry/Profession requirements)

Signals and Systems is an advance course; hence it only lays down the foundation of pattern recognition and classification problem.

POs met through Gaps in the Syllabus

May be met through laboratory simulations, experiments, and design problems.

Topics beyond syllabus/Advanced topics/Design

1. Application of **Signals and Systems** in the analysis of time varying signal.
2. Extraction of Pattern vector from time varying signal for the development of decision support system for various applications.

POs met through Topics beyond syllabus/Advanced topics/Design

Assignments & Seminars

Course Outcome (CO) Attainment Assessment Tools & Evaluation Procedure**Direct Assessment**

Assessment Tool	% Contribution during CO Assessment
First Quiz	10

Mid Semester Examination	25
Second Quiz	10
Teacher's Assessment	5
End Semester Examination	50

Indirect Assessment

1. Students' Feedback on Course Outcome.

Mapping of Course Outcomes onto Program Outcomes

Course Outcome	Program Outcomes (POs)												Program Specific Outcomes (PSOs)		
	1	2	3	4	5	6	7	8	9	10	11	12	13	14	15
CO1	2	2	3	3	2	3	1	2	3	3	3	3	3	3	2
CO2	2	2	3	3	2	3	1	2	3	3	3	3	3	3	2
CO3	2	2	3	3	2	3	1	3	3	3	3	3	3	3	2
CO4	2	2	3	3	2	3	1	2	3	3	3	3	3	3	2
CO5	1	1	1	1	1	1	1	1	1	1		1	3	3	2

Correlation Levels 1, 2 or 3 as defined below:

1: Slight (Low) 2: Moderate (Medium) 3: Substantial (High)

Mapping between COs and Course Delivery (CD) methods

CD Code	Course Delivery Methods	Course Outcome	Course Delivery Method Used
CD1	Lecture by use of Boards/LCD Projectors	CO1	CD1, CD2, CD5, CD8

CD2	Tutorials/Assignments	CO2	CD1, CD2, CD5, CD8
CD3	Seminars	CO3	CD1, CD2, CD3, CD4, CD5, CD8, CD9.
CD4	Mini Projects/Projects	CO4	CD1, CD2, CD3, CD4, CD5, CD8, CD9.
CD5	Laboratory Experiments/Teaching Aids	CO5	CD4, CD5, CD7, CD9
CD6	Industrial/Guest Lectures		
CD7	Industrial Visits/In-plant Training		
CD8	Self- learning such as use of NPTEL Materials and Internets		
CD9	Simulation		

COURSE INFORMATION SHEET
Electronic Measurements

Course code: EC207

Course title: Electronic Measurements

Pre-requisite(s): EC101 Basics of Electronics & Communication Engineering **Co-requisite(s):**

Credits: L: 3 T: 0 P: 0 C: 3

Class schedule per week: 3

Class: B. Tech

Semester / Level: III/03 *In-depth Specialization/Programme Elective*

Branch: ECE

Name of Teacher:

Course Objectives

This course enables the students to:

1.	Understand the need and concept of measurement, calibration, standards, errors, static and dynamic performance characteristics of measuring instruments.
2.	Demonstrate the operating principles of different analog and digital instruments.
3.	Experiment and analyze various a.c. and d.c. bridges for the measurement.
4.	Explain the operation and construction of analog and digital CRO used for different parameter measurement in the department laboratory.
5.	Solve the problems of measuring non electrical parameters using different transducers.

Course Outcomes

After the completion of this course, students will be able to:

CO1	Find and investigate errors and explain the static and dynamic characteristics of instruments.
CO2	Explain the working of different analog instruments (PMMC, Moving iron) and use them to design multi-range voltage, current and resistance measuring instruments.
CO3	Demonstrate the process of balancing different bridge networks to find the value of unknown arm components.
CO4	Summarize the working of analog and digital CRO.
CO5	Schematize the measurement of non-electrical parameters using different transducers.

SYLLABUS

MODULE	(NO. OF LECTURE HOURS)
<p>Module – I Introduction of measurements and measurement systems: Significance of measurements, different methods of measurements, Instruments used in measurements, Electronic Instruments and its classification, Elements of a Generalized Measurement System. Characteristics of instruments, Static characteristics, Errors in measurements, scale, range, and scale span, calibration, Reproducibility and drift, Noise, Accuracy and precision, Significant figures, Linearity, Hysteresis, Threshold, Dead time, Dead zone, Resolution and Loading Effects.</p>	8
<p>Module – II Analogue Instruments: Classification and Principles of Operation, Working Details Moving Coil (PMMC) and Moving Iron Instruments Construction, DC Ammeter, DC Voltmeter, Series and Shunt type Ohmmeter. Analogue Electronic voltmeter, DC Voltmeter with chopper type DC amplifier.</p>	8
<p>Module – III Introduction of DC and AC Bridges: Wheatstone Bridge, Kelvin Double Bridge, Maxwell's Bridge, and Hay's Bridge, Anderson's Bridge, Schering's Bridge, Wien's Bridge, Sources of errors in Bridges and their elimination by shielding and grounding, Q meter. Oscilloscopes: CRT, Construction, Basic CRO circuits, Block diagram of a modern oscilloscope, Y-amplifiers, X-amplifiers, Triggering, Oscilloscopic measurement. Special CRO's: Dual trace, Dual beam.</p>	8
<p>Module – IV Digital Instruments and D/A and A/D converters: Sample-and-hold circuit, D/A converters: Weighted-resistor D/A Converter, R-2R Ladder type D/A converter, Specifications for D/A Converters, A/D Converters: Parallel-comparator type A/D converter, Successive approximation type A/D converter, Counter type A/D converter, Dual slope converter, Comparison of converter types, Digital Voltmeters, Digital Multimeters, Digital frequency Meter, Sampling oscilloscope, Storage CROs.</p>	8
<p>Module – V Transducers: Definition, Classification, Principle of Analogue transducer: Resistive (Strain Gauge, POT, Thermistor and RTD), Capacitive, Piezoelectric, Thermocouple and Inductive (LVDT) and RVDT) transducer, Working principle of Digital Transducer and Optical transducer. Application of above transducers to be discussed on the basis of Pressure, Displacement, Level, Flow and Temperature measurements.</p>	8

Books recommended:**Textbooks:**

1. “Electrical and Electronic Measurements and Instrumentation” by A. K. Sawhney.
2. “Modern Electronic Instrumentation & Measurement Techniques” by Helfrick & Cooper.

Reference books:

1. “Electronic Instrumentation”, by H. S. Kalsi.

Gaps in the syllabus (to meet Industry/Profession requirements): Visit to CIF, BIT Mesra.

POs met through Gaps in the Syllabus: N/A

Topics beyond syllabus/Advanced topics/Design: N/A

POs met through Topics beyond syllabus/Advanced topics/Design: N/A

Course Outcome (CO) Attainment Assessment Tools & Evaluation Procedure**Direct Assessment**

Assessment Tool	% Contribution during CO Assessment
First Quiz	10
Mid Semester Examination	25
Second Quiz	10
Teacher’s Assessment	5
End Semester Examination	50

Indirect Assessment

1. Students’ Feedback on Course Outcome.

Mapping of Course Outcomes onto Program Outcomes

Course Outcome	Program Outcomes (POs)												Program Specific Outcomes (PSOs)		
	1	2	3	4	5	6	7	8	9	10	11	12	1	2	3
CO1	3	3	2	3	3	1	1			3		3	3	2	1
CO2	3	3	2	3	3	3	2			3		3	3	2	1
CO3	3	3	2	3	3	3	2			3		3	3	2	1

CO4	3	3	2	3	3	2	2			3		3	3	2	1
CO5	3	3	2	3	3	2	2			3		3	3	2	1

Correlation Levels 1, 2 or 3 as defined below:

1: Slight (Low) 2: Moderate (Medium) 3: Substantial (High)

Mapping Between COs and Course Delivery (CD) methods

CD Code	Course Delivery Methods	Course Outcome	Course Delivery Method Used
CD1	Lecture by use of Boards/LCD Projectors	CO1	CD1,CD2,CD5,CD8
CD2	Tutorials/Assignments	CO2	CD1,CD2,CD5,CD8
CD3	Seminars	CO3	CD1,CD2,CD5,CD8
CD4	Mini Projects/Projects	CO4	CD1,CD2,CD5,CD8
CD5	Laboratory Experiments/Teaching Aids	CO5	CD1,CD2,CD5,CD8
CD6	Industrial/Guest Lectures		
CD7	Industrial Visits/In-plant Training		
CD8	Self- learning such as use of NPTEL Materials and Internets		
CD9	Simulation		

COURSE INFORMATION SHEET

NETWORK THEORY

Course code: EC209

Course title: NETWORK THEORY

Pre-requisite(s): Basics of Electrical Engineering

Co- requisite(s): Mathematics

Credits: 3 L:3 T:0 P:0

Class schedule per week: 03

Class: B. Tech

Semester / Level: 02

Branch: ECE Name of

Teacher:

Course Objectives:

This course enables the students to:

- A. list the Properties and discuss the concepts of graph theory
- B. solve problems related to network theorems
- C. illustrate and outline the Multi-terminal network in engineering
- D. select and design of filters

Course Outcomes:

After the completion of this course, students will:

1. be able to solve problems related to DC and AC circuits
2. become adept at interpreting network analysis techniques
3. be able to determine response of circuits consisting of dependent sources
4. analyse linear and non-linear circuits
5. be able to design the filters with help of electrical element

Syllabus:

Module – I

Network Topology: Definition and properties, Matrices of Graph, Network Equations & Solutions: Node and Mesh transformation; Generalized element; Source transformation; Formulation of network equations; Network with controlled sources; Transform networks; Properties of network matrices; Solution of equations; Linear timeinvariant networks; Evaluation of initial conditions; Frequency and impedance scaling.

Module – II

Network Theorem: Substitution theorem, Tellegen's theorem, Reciprocity theorem; State space concept and State variable modelling.

Module – III

Multi-terminal Networks: Network function, transform networks, natural frequency (OCNF and SCNF); Two-port parameters, Equivalent networks.

Module – IV

Elements of Network Synthesis: Positive real function, Reactance functions, RC functions, RL Network, Two-port functions, Minimum phase networks.

Module – V

Approximation: Filter specifications; Butterworth approximation; Chebyshev approximation; Frequency transformation; High pass; Band pass; all pass and notch filter approximation.

Text Books:

1. V.K. Aatre, Network Theory & Filter Design, New Age International Pvt. Ltd., New Delhi. (T1)
2. M.S. Sukhija, T.K.Nagsarkar, Circuits and Networks, Oxford University Press, 2nd ed., New Delhi.(T2)

Reference Books:

1. M.E. Van Valkenberg, Introduction to Modern Network Synthesis, John Wiley & Sons (1 January 1966) (R1)
2. Balabanian, N. and T.A. Bickart, “Electric Network Theory”, John Wiley & Sons, New York, 1969. (R2) 3. C. L. Wadhwa, Network Analysis and Synthesis, New Age International Pvt. Ltd., New Delhi(R2)

Gaps in the syllabus (to meet Industry/Profession requirements):

- i. Practical aspects and demonstration of electrical and non-electrical systems

POs met through Gaps in the Syllabus:

- a) Demonstrate appropriate inter-personal skills to function effectively as an individual, as a member or as a leader of a team and in a multi-disciplinary setting (POi)
- b) Be able to comprehend and write effective reports and design documentations; give and receive clear instructions; make effective presentations and communicate effectively and convincingly on complex engineering issues with engineering community and with society at large. (POj)
- c) Be conscious of financial aspects of all professional activities and shall be able to undertake projects with appropriate management control and control on cost and time. (POk)
- d) Recognize the need for continuous learning and will prepare himself/ herself appropriately for his/her allround development throughout the professional career. (POl)

Topics beyond syllabus/Advanced topics/Design:

- i. Design of filter using operational amplifier

POs met through Topics beyond syllabus/Advanced topics/Design:

Course Delivery methods
Lecture by use of boards/LCD projectors/OHP projectors
Tutorials/Assignments
Seminars
Mini projects/Projects
Laboratory experiments/teaching aids
Industrial/guest lectures
Industrial visits/in-plant training

Self- learning such as use of NPTEL materials and internets

Simulation

Course Outcome (CO) Attainment Assessment tools & Evaluation procedure:

Direct Assessment

Assessment Tool	% Contribution during CO Assessment
Mid Sem Examination Marks	25
End Sem Examination Marks	50
Assignment	05
Quiz (s)	20

Assessment Components	CO1	CO2	CO3	CO4	CO5
Mid Sem Examination Marks	√	√	√		
End Sem Examination Marks	√	√	√	√	√
Assignment				√	√

Indirect Assessment –

1. Student Feedback on Faculty
2. Student Feedback on Course Outcome

Mapping between Objectives and Outcomes:

Mapping of Course Outcomes onto Program Outcomes

Course Outcome #	Program Outcomes											
	a	b	c	d	e	f	g	h	i	j	k	l
1	3	3	2							1	1	1
2	3	3	3	2	1					1	1	1
3	3	3	3	3	2	2				1	1	1
4	3	3	3	3	3	3				2	2	2
5	3	3	3	2	2	3	3	3	3	1	3	3

CD	Course Delivery methods	Course Outcome	Course Delivery Method
CD1	Lecture by use of boards/LCD projectors/OHP projectors	CO1	CD1
CD2	Tutorials/Assignments	CO2	CD1
CD3	Seminars	CO3	CD1 and CD2
CD4	Mini projects/Projects		
CD5	Laboratory experiments/teaching aids		

CD6	Industrial/guest lectures		
CD7	Industrial visits/in-plant training		
CD8	Self- learning such as use of NPTEL materials and internets		
CD9	Simulation		

COURSE INFORMATION SHEET

Probability and Random Processes

Course code: **EC251**

Course title: **Probability and Random Processes**

Pre-requisite(s): EC205 Signals and Systems

Co- requisite(s):NA

Credits: L: 3 T: 0 P: 0 C: 3

Class schedule per week: 03 Class: B.

Tech.

Semester / Level: IV/02

Branch: ECE

Name of Teacher:

Course Objectives:

This course enables the students:

1.	To explain the random phenomena and impart knowledge on the mathematical modelling of the random experiment.
2.	To develop an ability to describe random vectors and their characterization.
3.	To develop an ability to understand the concept of random processes or stochastic processes.
4.	To develop an ability to analyze the stochastic processes with the help of probability models and its characterization
5.	To develop an ability to evaluate different emerging techniques to improve real-time estimation and detection of random parameters.

Course Outcomes:

After the completion of this course, students will be able to:

CO1	Demonstrate an understanding of the mathematical modelling of the random experiment or random phenomena.
CO2	Describe random vectors and their characterization.
CO3	Demonstrate an understanding of the concept of random processes or stochastic processes.
CO4	Analyze the stochastic processes with the help of probability models and their characterization.
CO5	Evaluate the different emerging techniques to improve real-time estimation and detection of random parameters.

SYLLABUS

MODULE	(NO. OF LECTURE HOURS)
<p>Module – I Randomness, Uncertainty and its Description Random experiments/phenomenon, outcomes of the random experiment, Sample Space, Events, Probability of an event, Concepts of sets and probability theory to explain Random experiments, Probability space; Conditional probability, Independence and Bayes theorem; Combinatorial probability and sampling models.</p>	8
<p>Module – II Random Variable and its characterization: Continuous random variables: distribution function, probability density function, Conditional Densities and Distributions, an example of distributions, Gaussian, Rayleigh, and Rician; exponential, chi-squared; gamma. Discrete random variables: distribution function, probability mass function, Example of random variables and distributions (Bernoulli, binomial, Poisson, geometric, negative binomial, etc.), Expectations, Variance, MGF and Characteristics Function of Random Variable, moments of Random Variable.</p>	9
<p>Module – III Random vector and its characterization: Joint Events, Joint CDF and PDF, Properties of Joint CDF and PDF, Bivariate Gaussian Distributions, Joint Moments, Random Vectors, Vector Gaussian Random Variables, Moments of Random Vectors, Independence of two random vectors</p>	9
<p>Module – IV Inequalities, Convergences, and Limit Theorems: Random sequences Markov, Chebyshev and Chernoff bounds; modes of convergence (everywhere, almost everywhere, probability, distribution and mean square); Stochastic convergence, the law of large numbers, central limit theorem, Limit theorems; Strong and weak laws of large numbers.</p>	8
<p>Module – V Random Processes and Linear Systems: Random Data/Signals, stationarity; mean, correlation, and covariance functions, WSS random process; autocorrelation and cross-correlation functions; transmission of a random process through a linear System; power spectral density; white random process; Gaussian process; Poisson process, Application of Probability and Random Processes to understand important domain like digital communication, estimation and information theory.</p>	6

Text Books:

1. Papoulis. A.,” Probability, Random variables, and Stochastic Processes”, McGraw Hill, 2002.
2. H.Stark & J.W.Woods, “Probability, Random Processes and Estimations Theory for Engineers”, (2/e), Prentice Hall, 1994

Reference Book:

1. E.Wong, “Introduction to Random Processes”, Springer Verlag, 1983.
2. W.A.Gardner, “Introduction to Random Processes”, (2/e), McGraw Hill, 1990.
3. Davenport,” Probability and Random Processes for Scientist and Engineers”, McGraw-Hill, 1970.

Gaps in the Syllabus (to meet Industry/Profession requirements)

Probability and Random Processes is an advance course; hence it only lays down the foundation of pattern recognition and classification problem.

POs met through Gaps in the Syllabus

May be met through laboratory simulations, experiments, and design problems.

Topics beyond syllabus/Advanced topics/Design

1. Application of **Probability and Random Processes** in the analysis of time varying signal.
2. Extraction of Pattern vector from time varying signal for the development of decision support system for various applications.

POs met through Topics beyond syllabus/Advanced topics/Design

Assignments & Seminars

Course Outcome (CO) Attainment Assessment Tools & Evaluation Procedure**Direct Assessment**

Assessment Tool	% Contribution during CO Assessment
First Quiz	10
Mid Semester Examination	25
Second Quiz	10

Teacher's Assessment	5
End Semester Examination	50

Indirect Assessment

1. Students' Feedback on Course Outcome.

Mapping of Course Outcomes onto Program Outcomes

Course Outcome	Program Outcomes (POs)												Program Specific Outcomes (PSOs)		
	1	2	3	4	5	6	7	8	9	10	11	12	13	14	15
CO1	2	2	3	3	2	3	1	2	3	3	3	3	3	3	1
CO2	2	2	3	3	2	3	1	2	3	3	3	3	3	3	1
CO3	2	2	3	3	2	3	1	3	3	3	3	3	3	3	1
CO4	2	2	3	3	2	3	1	2	3	3	3	3	3	3	1
CO5	1	1	1	1	1	1	1	1	1	1		1	3	3	1

Correlation Levels 1, 2 or 3 as defined below:

1: Slight (Low) 2: Moderate (Medium) 3: Substantial (High)

Mapping between COs and Course Delivery (CD) methods

CD Code	Course Delivery Methods	Course Outcome	Course Delivery Method Used
CD1	Lecture by use of Boards/LCD Projectors	CO1	CD1, CD2, CD5, CD8
CD2	Tutorials/Assignments	CO2	CD1, CD2, CD5, CD8
CD3	Seminars	CO3	CD1, CD2, CD3, CD4, CD5, CD8, CD9.

CD4	Mini Projects/Projects	CO4	CD1, CD2, CD3, CD4, CD5, CD8, CD9.
CD5	Laboratory Experiments/Teaching Aids	CO5	CD4, CD5, CD7, CD9
CD6	Industrial/Guest Lectures		
CD7	Industrial Visits/In-plant Training		
CD8	Self- learning such as use of NPTEL Materials and Internets		
CD9	Simulation		

COURSE INFORMATION SHEET

Analog Circuits

Course code: EC253 R1

Course title: Analog Circuits

Pre-requisite(s): EC101 Basics of Electronics & Communication Engineering

Co-requisite(s): None

Credits: L: 3 T: 0 P: 0 C: 3.0

Class schedule per week: 03

Class: B. Tech

Semester / Level: 04

Branch: ECE

Name of Teacher:

Course Objectives

This course enables the students:

1.	To help them understand the operation of Transistors for low frequency applications and power amplifiers
2.	To know the operation of multistage amplifiers and transistors for high frequency applications and tuned amplifiers
3.	To help them understand the operation of feedback amplifiers and oscillators
4.	To help them realize the non-linear applications of op-amp and filters
5.	To help them understand sweep circuits and time base generators.

Course Outcomes

After the completion of this course, students will be able to:

CO1	Understand the concept of amplifiers, oscillators and active filter circuits.
CO2	Demonstrate the working of amplifiers, oscillators and active filter circuits.
CO3	Analyze amplifiers, filters at low and high frequency.
CO4	Evaluate amplifiers, oscillator, filters circuits.
CO5	Designing sweep circuits and time base generators.

Syllabus

MODULE	(NO. OF LECTURE HOURS)
Module – I Wave shaping circuits: RC low pass and high pass circuits and their response to sinusoidal, step, pulse, and square wave inputs, clipping and clamping circuits. Review of hybrid and simplified models of CE, CB, CC configurations of BJT. CE amplifier with emitter resistance, Emitter follower, Darlington Circuit, Cascode Amplifier.	10
Module – II Transistor Power Amplifiers: Class A, Class B, Class C and Push-Pull Configurations. Multistage amplifiers: Frequency response of an amplifier, Bandpass of cascaded stages, Low frequency response of RC coupled amplifier. Transistors at High Frequencies: Hybrid model and parameters; high frequency response of CE transistor amplifier, Gain-Bandwidth product, Emitter follower at high frequencies, FET (CS & CD) at high frequencies, Single-tuned amplifier.	10
Module – III Feedback Amplifiers: Classification of amplifiers, feedback concept, transfer gain with feedback, characteristics of negative-feedback amplifier, method of analysis of feedback amplifiers, voltage-series feedback, current-series feedback, current-shunt feedback, voltage-shunt feedback. Concept of stability, gain margin and phase margin. Oscillators: RC phase shift oscillator, Wien bridge oscillator, crystal oscillator. Current mirror circuits.	10
Module – IV Emitter-coupled differential amplifier, transfer characteristics of differential amplifier, IC of operational amplifier: gain stages and output stages, Electronic analog computation using op-amp, Non-linear applications of OP-AMP: zero-crossing detector, precision rectifier, peak detector, logarithmic amplifier, Schmitt trigger. Active filters: Low pass, high pass, band pass and band stop, design guidelines.	7
Module – V Negative resistance switching devices and circuits: Tunnel diode, UJT, Voltage controlled and Current controlled negative resistance circuits, Negative-Resistance Characteristics, Monostable, Bistable, and Astable operations, Applications using Tunnel diode and UJT. Sweep circuits: Time base Signal, Miller and Bootstrap Time base Generators-Basic Principles, Transistor Miller Time Base generator, Transistor Bootstrap Time Base Generator, Transistor Current Time Base Generators, Methods of Linearity improvement.	8

Text books:

1. "Integrated Electronics", Millman & Halkias, TMH
2. "Electronics Circuits: Discrete and Integrated", D. Schilling and C. Belove, McGraw-Hill
3. "Operational Amplifiers and Linear Integrated Circuits" by R. A. Gayakwad, PHI
4. "Digital Integrated Electronics". Taub & Schilling, TMH.

Reference books:

1. "Electronic Devices and Circuit", Millman , Halkias, S Jit, TMH
2. "Micro Electronic Circuits", A. S. Sedra and K. C. Smith, Oxford press

Gaps in the syllabus (to meet Industry/Profession requirements):

POs met through Gaps in the Syllabus:

Topics beyond syllabus/Advanced topics/Design:

POs met through Topics beyond syllabus/Advanced topics/Design:

Course Delivery Methods

CD1	Lecture by use of boards/LCD projectors/OHP projectors
CD2	Assignments
CD3	Laboratory experiments/teaching aids/Seminars
CD4	Industrial/guest lectures
CD5	Industrial visits/in-plant training
CD6	Self- learning such as use of NPTEL materials and internets
CD7	Simulation

Course Outcome (CO) Attainment Assessment tools & Evaluation procedure

Direct Assessment

Assessment Tools	% Contribution during CO Assessment
Continuous Internal Assessment	50
Semester End Examination	50

Continuous Internal Assessment	% Distribution
Mid semester examination	25
Two quizzes	20 (2×10)
Teacher's Assessment	5

Assessment Components	CO1	CO2	CO3	CO4	CO5
Continuous Internal Assessment					
Semester End Examination					

Indirect Assessment

1. Student Feedback on Faculty
2. Student Feedback on Course

Course Delivery Methods

CD1	Lecture by use of boards/LCD projectors/OHP projectors
-----	--

CD2	Assignments
CD3	Laboratory experiments/Teaching aids/Seminars
CD4	Mini Projects
CD5	Industrial visits/in-plant training
CD6	Self- learning such as use of NPTEL materials and internets
CD7	Simulation

Mapping between Course Outcomes and Program Outcomes and Program Specific Outcomes

Course Outcome	Program Outcomes (POs)												Program Specific Outcomes (PSOs)		
	1	2	3	4	5	6	7	8	9	10	11	12	13	14	15
CO1	3	3	2	3	3	1	1			3		3	3	3	3
CO2	3	3	2	3	3	2	1			3		3	3	3	3
CO3	3	3	2	3	3	2	1			3		3	3	3	3
CO4	3	3	2	3	3	3	1			3		3	3	3	3
CO5	3	3	2	3	3	3	1			3		3	3	3	3

< 34% = 1, 34-66% = 2, > 66% = 3

Mapping between Course Outcomes and Course Delivery Method

Course Outcomes	Course Delivery Method
CO1	CD1, CD2, CD3, CD6, CD7
CO2	CD1, CD2, CD3, CD6, CD7
CO3	CD1, CD2, CD3, CD6, CD7
CO4	CD1, CD2, CD3, CD6, CD7
CO5	CD1, CD2, CD3, CD6, CD7

COURSE INFORMATION SHEET

Analog Circuits Lab.

Course code: **EC254 R1**

Course title: **Analog Circuits Lab.**

Pre-requisite(s): EC101 Basics of Electronics & Communication Engineering

Co- requisite(s): Analog Circuits

Credits: L: 0 T: 0 P: 3 C: 1.5

Class periods per week: 03

Class: B. Tech.

Semester / Level: IV

Branch: ECE

Name of Teacher:

Course Objectives

This course enables the students to:

1.	Realize the two-stage amplifier and simple tuned amplifier circuits.
2.	Implement the Feedback amplifier circuits.
3.	Realize the differential amplifier and oscillator.
4.	Realize the active band pass, band stop filter circuits.
5.	Know the operation time base generator circuits.

Course Outcomes

After the completion of this course, students will be able to:

CO1	Design two-stage amplifier and simple tuned amplifier circuits.
CO2	Analyze and analyze the feedback amplifier circuits.
CO3	Characterize and Characterize the differential amplifier and oscillator.
CO4	Characterize the active band pass, band stop filter circuits.
CO5	Design time base generator circuits

List of Compulsory experiments:

Experiment No.	Name of the Experiments
1.	Design of a low pass and high pass RC circuits for a given cutoff frequency and obtain its frequency response and observe the response for square waveform for $T \ll RC$, $T = RC$ and $T \gg RC$. AIM1: Obtain the frequency response of a low pass and high pass RC circuits RC circuit with sine wave input. AIM2: Plot the output for square wave input under $T \ll RC$, $T = RC$ and $T \gg RC$.
2.	Determine the h-parameters: h_{ie} and h_{fe} of a transistor. AIM1: Design a CE transistor circuit to evaluate the h_{ie} . AIM2: Design a CE transistor circuit to evaluate the h_{fe} .
3.	Design and obtain the frequency response characteristics of Darlington pair amplifier.

	<p>AIM1: Design the circuit of a Darlington pair amplifier in emitter follower configuration and find the current gain of Darlington pair.</p> <p>AIM2: Find the frequency response of the Darlington pair amplifier.</p>
4.	<p>Determine the frequency response of Cascode Amplifier and find the input resistance and output resistance of the amplifier.</p> <p>AIM1: Design the BJT based cascode amplifier and find the frequency response.</p> <p>AIM2: Find the input and output resistance of the amplifier.</p>
5.	<p>Find the frequency response of (a) single stage and (b) multistage amplifiers. Determine the mid-band gain and bandwidth of the amplifiers.</p> <p>AIM1: Find the frequency response of single stage CE amplifier and determine the mid-band gain and bandwidth.</p> <p>AIM2: Find the frequency response of multistage CE amplifiers and determine the mid-band gain and bandwidth.</p>
6.	<p>Design a BJT based tuned amplifier. Find its frequency response.</p> <p>AIM1: Design a BJT based tuned amplifier and Find its frequency response.</p> <p>AIM2: Compare the theoretical resonant frequency with the experimental result.</p>
7.	<p>Design (a) current-series, and (b) voltage-shunt feedback amplifier. Find the frequency response of both amplifiers with and without feedback.</p> <p>AIM1: Design current-series feedback amplifier and Find the frequency response.</p> <p>AIM2: Design voltage-shunt feedback amplifier and Find the frequency response.</p>
8.	<p>Design a differential amplifier using BJT and determine the CMRR.</p> <p>AIM1: Design a differential amplifier using BJT and determine the differential mode gain at different frequencies.</p> <p>AIM2: Design a differential amplifier using BJT and determine the common mode gain at different frequencies. Find the CMRR at those frequencies.</p>
9.	<p>Design and determine the characteristics of logarithmic and antilogarithmic amplifiers using op-amp.</p> <p>AIM1: Design a logarithmic amplifiers using op-amp and plot the output.</p> <p>AIM2: Design an antilogarithmic amplifiers using op-amp and plot the output.</p>
10.	<p>Design and determine the characteristics of Active filters: band pass, band stop.</p> <p>AIM1: Design a band pass filter and find frequency response.</p> <p>AIM2: Design a band stop filter and find frequency response.</p>
11.	<p>Design of Miller Sweep circuit and Boot Strap Sweep circuit and plotting of the output waveform.</p> <p>AIM: Design of Miller Sweep circuit and Boot Strap Sweep circuit and plotting of the output waveforms.</p>
12.	<p>Design of Wein bridge oscillator and UJT Relaxation Oscillator</p> <p>AIM1: Design the Wein bridge oscillator and calculate the theoretical gain of the main amplifier.</p> <p>AIM2: Design of UJT relaxation Oscillator with a given frequency and to observe waveforms.</p>

Text books:

1. "Integrated Electronics", Millman & Halkias, McGraw Hill.

Reference books:

1. "Electronic Devices and Circuit Theory", Nashelsky & Boylestead, PHI/Low price edition.

Gaps in the syllabus (to meet Industry/Profession requirements):

POs met through Gaps in the Syllabus:

Topics beyond syllabus/Advanced topics/Design: through experiments involving design/modelling of device/circuits on advanced topics

POs met through Topics beyond syllabus/Advanced topics/Design: through experiments involving design/modelling of device/circuits on advanced topics

Course Delivery Methods

CD1	Lecture by use of boards/LCD projectors/OHP projectors
CD2	Assignments
CD3	Laboratory experiments/teaching aids/Seminars
CD4	Industrial/guest lectures
CD5	Industrial visits/in-plant training
CD6	Self- learning such as use of NPTEL materials and internets
CD7	Simulation

Course Outcome (CO) Attainment Assessment tools & Evaluation procedure

Course Delivery Methods

CD1	Lecture by use of boards/LCD projectors/OHP projectors
CD2	Assignments
CD3	Laboratory experiments/teaching aids/Seminars
CD4	Industrial/guest lectures
CD5	Industrial visits/in-plant training
CD6	Self- learning such as use of NPTEL materials and internets
CD7	Simulation

Course Outcome (CO) Attainment Assessment Tools and Evaluation Procedure

Direct Assessment

Assessment Tools	% Contribution during CO Assessment
Continuous Internal Assessment	60
Semester End Examination	40

Continuous Internal Assessment	% Distribution
Day to day performance & Lab files	30

Quiz(zes)	10
Viva	20

Semester End Examination	% Distribution
Examination Experiment Performance	30
Quiz	10

Assessment Components	CO1	CO2	CO3	CO4	CO5
Continuous Internal Assessment					
Semester End Examination					

Indirect Assessment

1. Student Feedback on Faculty
2. Student Feedback on Course

Course Delivery Methods

CD1	Lecture by use of boards/LCD projectors/OHP projectors
CD2	Assignments
CD3	Laboratory experiments/Teaching aids/Seminars
CD4	Mini Projects
CD5	Industrial visits/in-plant training
CD6	Self- learning such as use of NPTEL materials and internets
CD7	Simulation

Mapping between Course Outcomes and Program Outcomes and Program Specific Outcomes

Course Outcome	Program Outcomes (POs)												Program Specific Outcomes (PSOs)		
	1	2	3	4	5	6	7	8	9	10	11	12	13	14	15
CO1	3	3	2	3	3	1	1			3		3	3	3	3
CO2	3	3	2	3	3	2	1			3		3	3	3	3
CO3	3	3	2	3	3	2	1			3		3	3	3	3
CO4	3	3	2	3	3	3	1			3		3	3	3	3
CO5	3	3	2	3	3	3	1			3		3	3	3	3

< 34% = 1, 34-66% = 2, > 66% = 3

Mapping between Course Outcomes and Course Delivery Method

Course Outcomes	Course Delivery Method
CO1	CD3, CD7
CO2	CD3, CD7
CO3	CD3, CD7
CO4	CD3, CD7
CO5	CD3, CD7

COURSE INFORMATION SHEET
Electromagnetic Field and Waves

Course Code: EC257

Course Title: Electromagnetic Field and Waves

Pre-requisite(s): Engineering Mathematics Co- requisite(s):

Credits: L: 3 T: 0 P: 3

Class schedule per week: 03

Class: B. Tech.

Semester / Level: Four

Branch: Electronics and Communication Engineering

Name of Teacher:

Course Objectives

This course envisions to impart to students to:

1.	To apply the basic skills of mathematics, physics and science to understand, design and develop various engineering problems involving electromagnetic fields.
2.	To lay the foundations of electromagnetic engineering and its applications in modern communications involving both wireless and guided wave medium.
3.	To analyse the electromagnetic wave propagation in guided and unguided medium having different medium properties and different boundary conditions.
4.	To develop an ability to identify, formulate, and solve electromagnetic engineering problems.
5.	To review and present the literature ethically and also develop the skill to work individually or in a team.

Course Outcomes

After the completion of this course, students will be able to:

CO1	Explain the basic concepts of time varying electric and magnetic fields in different electromagnetic media.
CO2	Analyze Maxwell's equation in differential and integral forms and apply them to diverse engineering problems.
CO3	Examine and understand the phenomena of wave propagation in different media and its interfaces as well as in guided medium and its applications in microwave engineering.
CO4	Identify, formulate and solve electromagnetic engineering problems.
CO5	Work in a small team and communicate electromagnetic concepts both orally and in writing following ethical rules.

SYLLABUS

MODULE	(NO. OF LECTURE HOURS)
<p>Module – I Introduction to Maxwell’s Equations: Faraday’s Law, Transformer & Motional EMF, Displacement Current, Maxwell’s Equations (Generalized form). Boundary Conditions and Wave Equation: Electromagnetic Boundary Conditions Time varying Potentials & Fields: Time varying Potentials, Time harmonic fields, Time harmonics Maxwell’s Equations.</p>	8
<p>Module – II EM Wave propagation: Wave Equation & Plane Waves in unbounded homogeneous, plane waves in free space and lossy media, Skin depth, Poynting vector and Power considerations, Polarization of Electromagnetic waves, Reflection of a plane wave at Normal incidence and Oblique incidence. Parallel & Perpendicular Polarization at perfect conducting & dielectric boundaries, Brewster’s Angle.</p>	9
<p>Module – III Transmission lines: Transmission line parameters & Equations, Input Impedance, SWR and Power , The Smith Chart, Quarter Wave Transformer Matching, Single Stub Tuner(Matching), Slotted line (Impedance Measurement, Transients on transmission lines, Microstrip Transmission lines, strip lines, Slot lines and Co-planar lines.</p>	9
<p>Module – IV Waveguides: Transverse Electric and Transverse Magnetic wave propagation in Rectangular Waveguide, Rectangular Cavity Resonator, Circular Cavity Resonator, Quality factor of the rectangular Cavity Resonator.</p>	8
<p>Module – V Antennas: Radiation from the Hertz dipole, Power radiated by Hertzian dipole, Radiation Parameters of antenna, Monopole and Dipole antenna.</p>	6

Text Books:

1. Principle of Electromagnetics, Matthew N.O. *Sadiku* & S.V. Kulkarni, Oxford University Press, Sixth Edition.

Reference Books:

1. Electromagnetics field Theory and Transmission Line G.S.N Raju, Pearson Education
2. Electromagnetic Waves and Radiating Systems, 2/e, E. C. Jordan and K. G. Balmain, PHI.
3. Electromagnetics, David Cheng, Prentice Hall

Gaps in the Syllabus (to meet Industry/Profession requirements)

EM field and Waves is a basic course, hence it only lays down the foundation of Advanced Courses.

POs met through Gaps in the Syllabus

May be met through laboratory simulations, experiments, and design problems.

Topics beyond syllabus/Advanced topics/Design

3. Application of EM fields and Waves in the analysis of EM interference
4. Design of Omni directional Antennas for various applications.

POs met through Topics beyond syllabus/Advanced topics/Design

Assignments & Seminars

Course Outcome (CO) Attainment Assessment Tools & Evaluation Procedure**Direct Assessment**

Assessment Tool	% Contribution during CO Assessment
First Quiz	10
Mid Semester Examination	25
Second Quiz	10
Teacher's Assessment	5
End Semester Examination	50

Indirect Assessment

1. Students' Feedback on Course Outcome.

Mapping of Course Outcomes onto Program Outcomes

Course Outcome	Program Outcomes (POs)												Program Specific Outcomes (PSOs)		
	1	2	3	4	5	6	7	8	9	10	11	12	13	14	15
CO1	3	1	1	1	2				1	1		2	3	1	2
CO2	2	1		1	2				1	1		2	2	2	2
CO3	3	1		1	2				1	1		2	2	2	2
CO4	1	2	1	2	2	1	1	1	1	1	1	2	3	3	3
CO5	1	1	1	1	2	1	1	2	1	1		2	2	2	2

Correlation Levels 1, 2 or 3 as defined below:

1: Slight (Low) 2: Moderate (Medium) 3: Substantial (High)

Mapping between COs and Course Delivery (CD) methods

CD Code	Course Delivery Methods	Course Outcome	Course Delivery Method Used
CD1	Lecture by use of Boards/LCD Projectors	CO1	CD1, CD2, CD5, CD8
CD2	Tutorials/Assignments	CO2	CD1, CD2, CD5, CD8
CD3	Seminars	CO3	CD1, CD2, CD3, CD4, CD5, CD8, CD9.
CD4	Mini Projects/Projects	CO4	CD1, CD2, CD3, CD4, CD5, CD8, CD9.
CD5	Laboratory Experiments/Teaching Aids	CO5	CD4, CD5, CD7, CD9
CD6	Industrial/Guest Lectures		
CD7	Industrial Visits/In-plant Training		
CD8	Self- learning such as use of NPTEL Materials and Internets		
CD9	Simulation		

COURSE INFORMATION SHEET
Electronic Measurements Lab

Course code: **EC208**

Course title: **Electronic Measurements Lab**

Pre-requisite(s): **EC101 Basics of Electronics & Communication Engineering** Co-requisite(s):

Credits: L: T: 0 P: 3 C: 1.5

Class schedule per week: 04 Class: B. Tech.

Semester / Level: III/02 Branch: ECE Name of

Teacher:

Course Objectives

This course enables the students to:

1.	Understand the concepts of calibration and measurement.
2.	Apply the concepts of AC bridges for the measurements of the different electrical parameters.
3.	Explain the basic principles of transducers and their uses for the measurements of different physical parameters.
4.	Demonstrate the signal analysis using digital storage oscilloscope.
5.	Design the signal conditioners and converters for different applications.

Course Outcomes

After the completion of this course, students will be able to:

CO1	To list the functions of various components of a measurement system.
CO2	Describe the balancing of different AC bridges and calculate unknown resistance, inductance, quality of a coil, and capacitance at balance condition.
CO3	Calibrate and measure different physical parameters using measurement systems.
CO4	Find and investigate the errors in measuring a parameter.
CO5	Schematize electronic measurement systems for the measurement of different physical parameters.

SYLLABUS

List of experiments:

1	AC BRIDGES Aim1. Balancing Maxwell's Bridge and measurements of Inductance, DC Resistance, and quality factor of a medium Q coil. Aim2. Balancing Schering's Bridge and measurements of Capacitance, leakage Resistance, and quality factor of a capacitor.
2	RISE-TIME MEASUREMENT OF RC CIRCUIT and WIEN'S Bridge Measurement Aim1. Measurement of the rise time of the RC circuit using Digital Storage Oscilloscope. Aim2. Balancing Wien's Bridge and measurements of frequency of unknown sinusoidal signal. Aim3. Balancing Wien's Bridge and measurements of total harmonic distortion of a 1KHz non-sinusoidal signal.
3	STRAIN GAUGES Aim1. Calibration and measurement of pressure (in Kg/cm ²) using diaphragm and strain gauge.
4	Temperature Transducers Aim1. Calibration and measurement of temperature (in °C) using RTD. Aim2. Calibration and measurement of temperature (in °C) Thermocouple, and Thermistor.
5	SPEED MEASUREMENT Aim1. Measurement of rotating speed in (RPM) using Photo-reflective and Magnetic pickup sensor.
6	LVDT Aim1. Calibration and measurement of displacement (in mm) using LVDT.
7	LEVEL MEASUREMENT Aim1. Calibration and measurement of the level (in cm) using Load Cell
8	TORQUE MEASUREMENT Aim1. Torque Measurement (in kgm) using reaction torque sensor.
9	INSTRUMENTATION AMPLIFIER Aim1. Design and implementation of an instrumentation amplifier for a variable gain of 50, 100 and 200.
10	VOLTAGE TO FREQUENCY CONVERTER Design Analog to Digital convertor using voltage to frequency converter technique.
11	Construction of R-2R Ladder type 4-bit D/A converter. AIM1: Design an R-2R Ladder type 4-bit D/A converter using op-amp and find the analog output voltage for all the digital inputs. AIM2: Find the resolution of the converter.
12	Construction of counter type A/D Converter. AIM1: Design a counter type A/D converter and find the digital output bits for different analog inputs. AIM2: Find the resolution of the converter.

Books recommended:**Textbooks:**

1. “Electrical and Electronic Measurements and Instrumentation” by A. K. Sawhney.
2. “Modern Electronic Instrumentation & Measurement Techniques” by Helfrick & Cooper.

Reference books:

1. “Electronic Instrumentation”, by H. S. Kalsi.

Gaps in the syllabus (to meet Industry/Profession requirements): Visit CIF lab at BIT Mesra.

POs met through Gaps in the Syllabus: N/A.

Topics beyond syllabus/Advanced topics/Design: Smart Sensors and Transmitters

POs met through Topics beyond syllabus/Advanced topics/Design: N/A

Course Outcome (CO) Attainment Assessment Tools and Evaluation Procedure Direct Assessment

Assessment Tools	% Contribution during CO Assessment
Continuous Internal Assessment	60
Semester End Examination	40

Continuous Internal Assessment	% Distribution
Day to day performance & Lab files	30
Quiz	10
Viva	20

Semester End Examination	% Distribution
Examination Experiment Performance	30
Quiz	10

Indirect Assessment**1. Students’ Feedback on Course Outcome****Mapping of Course Outcomes onto Program Outcomes**

Course Outcome	Program Outcomes (POs)												Program Specific Outcomes (PSOs)		
	1	2	3	4	5	6	7	8	9	10	11	12	1	2	3
CO1	3	3	3	3	3	1	1	1		3		3	2	2	1
CO2	3	3	3	3	3	1	1	1		3		3	2	2	1
CO3	3	3	3	3	3	1	1	1		3		3	2	2	1
CO4	3	3	3	3	3	1	1	1		3		3	2	2	1
CO5	3	3	3	3	3	1	1	1		3		3	2	2	1

Correlation Levels 1, 2 or 3 as defined below:

1: Slight (Low) 2: Moderate (Medium) 3: Substantial (High)

Mapping Between COs and Course Delivery (CD) methods

CD Code	Course Delivery Methods	Course Outcome	Course Delivery Method Used
CD1	Lecture by use of Boards/LCD Projectors	CO1	CD1, CD5, CD8, CD9
CD2	Tutorials/Assignments	CO2	CD1, CD5, CD8, CD9
CD3	Seminars	CO3	CD1, CD5, CD8, CD9
CD4	Mini Projects/Projects	CO4	CD1, CD5, CD8, CD9
CD5	Laboratory Experiments/Teaching Aids	CO5	CD1, CD5, CD8, CD9
CD6	Industrial/Guest Lectures		
CD7	Industrial Visits/In-plant Training		
CD8	Self- learning such as use of NPTEL Materials and Internets		
CD9	Simulation		

COURSE INFORMATION SHEET
Analog Communication

Course Code: EC301 R1

Course Title: Analog Communication

Pre-requisite(s): Good understanding of mathematical tools like integration, differentiation etc.

Co- requisite(s):

Credits: L: 3 T: 0 P: 0 C:3

Class schedule per week: 03

Class: B. Tech.

Semester / Level: Fourth/Second

Branch: Electronics & Communication Engineering

Name of Teacher:

Course Objectives

This course envisions to impart to students to:

1.	Explain analog communication system and representation of signals.
2.	Explain different methods of amplitude modulation and demodulation schemes, their design, operation and applications.
3.	Explain different methods of angle modulation and demodulation schemes, their design, operation and applications.
4.	Explain different methods of pulse modulation, their design, operation and applications.
5.	Evaluate the performance of analog communication system in the presence of noise.

Course Outcomes

After the completion of this course, students will be able to:

CO1	Demonstrate an understanding on analog communication system and representation of signals.
CO2	Demonstrate an understanding on different methods of amplitude modulation and demodulation schemes, their design, operation and applications.
CO3	Demonstrate an understanding on different methods of angle modulation and demodulation schemes, their design, operation and applications.
CO4	Demonstrate an understanding on different methods of pulse modulation, their design, operation and applications.
CO5	Evaluate the performance of analog communication system in the presence of noise.

SYLLABUS

MODULE	(NO. OF LECTURE HOURS)
<p>Module – I Signal analysis Time domain and frequency domain representation of a signal, Fourier series, complex Fourier spectrum (discrete spectrum or line spectrum), Fourier transform, properties of Fourier transform, energy and power spectral density spectrum, distortion less transmission, causality and physical realizability, pre-envelope and canonical representation of band pass signals.</p>	10
<p>Module – II Amplitude modulation- demodulation communication systems Amplitude modulation, square law modulator, switching modulator, square law demodulator, envelope detector, double side band suppressed carrier modulation, balanced and ring modulators, single side band modulation, frequency discrimination and phase discrimination modulators, coherent detection of SSB, frequency division multiplexing and time division multiplexing, super heterodyne AM receiver and its characteristics.</p>	7
<p>Module – III Angle modulation - demodulation communication systems Basics of frequency and phase modulation, single tone frequency modulation, NBFM, WBFM, Transmission bandwidth of FM wave, indirect and direct methods of FM generation, frequency discriminator, phase locked loop demodulator, super heterodyne FM receiver.</p>	7
<p>Module – IV Pulse modulation demodulation communication systems Sampling process, pulse amplitude modulation, pulse duration modulation, pulse position modulation.</p>	10
<p>Module – V Noise in communication systems Noise, shot noise, thermal noise, white noise, noise equivalent bandwidth, signal to noise ratio for coherent detection of DSBSC, SNR for coherent reception with SSB modulation, SNR for AM receiver using envelope detection, Noise in FM reception, FM Threshold effect, pre emphasis and de-emphasis.</p>	6

Text Books:

1. Simon Haykin, "Communication Systems", Wiley Eastern Limited, New Delhi, 2016, 4/e.
2. B. P. Lathi and Zhi Ding, "Modern Digital and Analog Communication Systems", Oxford University Press, 2011, 4/e, (Indian Edition)

Reference Books:

1. John G. Proakis and Masoud Salehi, “Fundamentals of Communication Systems” Pearson Education, Inc., New Delhi, 2013.
2. Bruce Carlson and Paul B. Crilly, “Communication Systems: An Introduction to signals and Noise in Electrical Communication”, Tata McGraw Hills Education Pvt. Ltd., New Delhi, 2011, 5/e.

Gaps in the Syllabus (to meet Industry/Profession requirements)**POs met through Gaps in the Syllabus:****Topics beyond syllabus/Advanced topics/Design:****POs met through Topics beyond syllabus/Advanced topics/Design:****Course Outcome (CO) Attainment Assessment Tools & Evaluation Procedure:PO2****Direct Assessment**

Assessment Tool	% Contribution during CO Assessment
First Quiz	10
Mid Semester Examination	25
Second Quiz	10
Teacher’s Assessment	5
End Semester Examination	50

Indirect Assessment

1. Students’ Feedback on Course Outcome.

Mapping of Course Outcomes onto Program Outcomes

Course Outcome	Program Outcomes (POs)												Program Specific Outcomes (PSOs)		
	1	2	3	4	5	6	7	8	9	10	11	12	13	14	15
CO1	3	2	2	1	-	-	-	-	-	-	-	2	3	2	1
CO2	3	3	3	3	2	-	-	-	-	-	-	1	3	2	2
CO3	3	3	3	3	2	-	-	-	-	-	-	1	3	2	1
CO4	3	3	3	3	2	-	-	-	-	-	-	1	3	2	3
CO5	3	3	3	3	3	-	-	-	-	-	-	1	3	2	2

Correlation Levels 1, 2 or 3 as defined below:

1: Slight (Low) 2: Moderate (Medium) 3: Substantial (High) **Mapping
Between COs and Course Delivery (CD) methods**

CD Code	Course Delivery Methods	Course Outcome	Course Delivery Method Used
CD1	Lecture by use of Boards/LCD Projectors	CO1	CD1, CD8
CD2	Tutorials/Assignments	CO2	CD1 ,CD8
CD3	Seminars	CO3	CD1, CD8
CD4	Mini Projects/Projects	CO4	CD1, CD8
CD5	Laboratory Experiments/Teaching Aids	CO5	CD1,CD8
CD6	Industrial/Guest Lectures		
CD7	Industrial Visits/In-plant Training		
CD8	Self- learning such as use of NPTEL Materials and Internets		
CD9	Simulation		

COURSE INFORMATION SHEET
Microprocessors and Microcontrollers

Course code: EC303 R1

Course title: Microprocessors and Microcontrollers

Pre-requisite(s): EC203 Digital system Design

Co- requisite(s):

Credits: L: 3 T: 0 P: 0

Class schedule per week: 03

Class: B.Tech.

Semester / Level: V/03

Branch: ECE

Name of Teacher:

Course Objectives

1.	To explain the basic building blocks of a Microprocessor/ Microcontroller architecture and the operation with relevant timing diagrams.
2.	To demonstrate the knowledge of different addressing modes and instruction set of a Microprocessor/ Microcontroller in developing efficient programing logic.
3.	To develop the interfacing circuits for different applications with appropriate peripherals.
4.	To analyze the evolution of Microprocessor/Microcontroller and compare the different features.
5.	To design a Microprocessor/ Microcontroller based system suitable for industrial applications.

Course Outcomes

After the completion of this course, students shall be able to:

CO1	Define the architectural differences between Microprocessor and Microcontroller.
CO2	Apply the programming concepts for the design of efficient codes.
CO3	Make use of different I/O chips for the desired application by programming them in different modes.
CO4	Illustrate the advancements made to the recent generations Microprocessor/ Microcontroller.
CO5	Develop Microprocessor/ Microcontroller based products to meet the industrial requirements.

SYLLABUS

MODULE	(NO. OF LECTURE HOURS)
Module – I Revision of logic circuits with emphasis on control lines, SAP concepts with stress on timing diagrams, Microinstructions, Microprogramming, Variable machine cycle, Architecture of 8085 Processor, Functions of all signals, Bus concepts, Multiplexed and De-multiplexed Bus. Instruction set, Addressing modes, Timing diagrams. FEO.	8
Module – II 8085 Programming examples on Time delay, Looping, Sorting and Code conversions. 8085 based Microcomputer system, Memory Organization, Memory Interfacing, Memory Mapped I/O, I/O Mapped I/O, Interrupts, Hardware and Software Interrupts, Interrupt instructions, Programmed I/O, Interrupt driven I/O, and DMA.	8
Module – III Introduction to 16-bit processor, 8086 architectures, BIU and EU, Pin description, Maximum and Minimum Mode, Instruction set, Addressing modes. Memory organization, Advantages of memory segmentation, Memory banking (even and odd), Programming Examples.	8
Module – IV Introduction of programmable peripheral interfacing (PPI), Architecture of 8255, Modes of operation, ADC 0801/0808, and its interfacing with 8085/86, DAC 0808 and its interfacing with 8085/86, Sample and Hold. DAS architecture and its programming in automation application. 8253(PIT), Modes of operation, Programming examples.	8
Module – V Introduction to Microcontrollers: Architecture of 8051, Memory structure. Pin descriptions, Instruction set, Addressing modes. Programming examples for simple control applications.	8

Books recommended:

Textbooks:

1. Digital Computer Electronics, 2/e. by A. P. Malvino.
2. Microprocessor Architecture, Programming and Applications with 8085 by R. S. Gaonkar.
3. Advanced Microprocessors and Peripherals by K. M. Bhurchandi and A. K. Ray.
4. The 8051 Microcontroller and Embedded System by Muhammad Ali Mazidi.
5. ARM architecture reference manual, 2/e by David Seal.

Reference books:

1. Intel Manual's for 8085, 8086, 8051 and other peripheral chips.
2. Advanced Microprocessor" by Y. Rajasree.
3. Microprocessor and Interfacing, Programming of Hardware" by Douglas Hall.

Gaps in the syllabus (to meet Industry/Profession requirements):

POs met through Gaps in the Syllabus: N/A

Topics beyond syllabus/Advanced topics/Design: N/A

POs met through Topics beyond syllabus/Advanced topics/Design: N/A

Course Outcome (CO) Attainment Assessment Tools & Evaluation Procedure

Direct Assessment

Assessment Tool	% Contribution during CO Assessment
First Quiz	10
Mid Semester Examination	25
Second Quiz	10
Teacher's Assessment	5
End Semester Examination	50

Indirect Assessment

1. Students' Feedback on Course Outcome.

Mapping of Course Outcomes onto Program Outcomes

Course Outcome	Program Outcomes (POs)												Program Specific Outcomes (PSOs)		
	1	2	3	4	5	6	7	8	9	10	11	12	13	14	15
CO1	3	3	2	3	3	1	1			3		3	3	3	2
CO2	3	3	2	3	3	3	2			3		3	3	3	2
CO3	3	3	2	3	3	3	2			3		3	3	3	2
CO4	3	3	2	3	3	2	2			3		3	3	3	2
CO5	3	3	2	3	3	2	2			3		3	3	3	2

Correlation Levels 1, 2 or 3 as defined below:

1: Slight (Low) 2: Moderate (Medium) 3: Substantial (High)

Mapping Between COs and Course Delivery (CD) methods

CD Code	Course Delivery Methods	Course Outcome	Course Delivery Method Used
CD1	Lecture by use of Boards/LCD Projectors	CO1	CD1,CD2 and CD 8
CD2	Tutorials/Assignments	CO2	CD1
CD3	Seminars	CO3	CD1, CD2
CD4	Mini Projects/Projects	CO4	CD1 and CD2
CD5	Laboratory Experiments/Teaching Aids	CO5	CD1 and CD2
CD6	Industrial/Guest Lectures		
CD7	Industrial Visits/In-plant Training		
CD8	Self- learning such as use of NPTEL Materials and Internets		
CD9	Simulation		

COURSE INFORMATION SHEET
Microprocessors and Microcontrollers Lab

Course code: EC304 R1

Course title: Microprocessors and Microcontrollers Lab

Pre-requisite(s):

Co- requisite(s):

Credits: L: 3 T: 0 P: 0

Class schedule per week: 03 Class:

B. Tech.

Semester / Level: V/ 03

Branch: ECE Name

of Teacher:

Course Objectives

1.	To develop efficient 8085 based program for different tasks.
2.	To develop efficient 8086 based program for different tasks.
3.	To develop efficient 8051 μ c based program for different tasks.
4.	To build interfacing circuits for different tasks.
5.	To be able to develop microprocessor and microcontrollers based systems for industrial applications.

Course Outcomes

After the completion of this course, students shall be able to:

CO1	Demonstrate the programming concepts of 8085/8086/8051 for efficient coding.
CO2	Show the interfacing of different peripherals with 8085/8086/8051.
CO3	Analyse the output of different peripherals when programmed in different modes using 8085/8086/8051.
CO4	Develop the interfacing circuits for different applications with appropriate peripherals.
CO5	Design 8085/8086/8051 based system for various real time applications.

SYLLABUS

Lab is the application of the theory (i.e., hands-on experiments related to the course contents). Therefore, **EC303 Microprocessors and Microcontrollers** is the syllabus for the **EC304 Microprocessors and Microcontrollers Lab**. Following experiments are the guidelines for the students. However, the questions for exams are not limited to this experiment list.

List of experiments:

8085 AND 8086 PROGRAMMING

1. Name of the Experiment

Data Transfers

Aim1: REARRANGING BYTES

Aim2: GROUPING ODD, EVEN, DIVIDE BY 4 AND DIVIDE BY 16 BYTES

Aim3: FORMATION OF A THIRD BLOCK

Aim4: FILLING UP 128 LOCATIONS

2. Name of the Experiment

Arithmetic Operations

Aim1: ADDITION OF 12 BYTES

Aim2: MULTIPLICATION OF SINGLE BYTE BY SINGLE BYTE

Aim3: ADDITION OF 18 BCD NO'S **Aim4:**

ADDITION OF TWO 10-BYTE NO'S

Aim5: ADDITION OF TWO 20-DIGIT BCD NO's:

Aim6: BCD SUBTRACTION

Aim7: MULTIPLICATION OF TWO 5-BYTE BINARY NUMBERS

Aim8: BCD MULTIPLICATION

Aim9: BINARY DIVISION

3. Name of the Experiment

Logical Operations

Aim1: CHECKING BITS OF A WORD

Aim2: LOGICAL OPERATION

4. Name of the Experiment

Data Processing

Aim1: NUMBER OF BITS IN BYTES

Aim2: MAXIMUM AND MINIMUM BYTES

Aim3: SIZE OF A BLOCK ENDING WITH A SPECIFIED BYTE

Aim4: SIZE OF A BLOCK STARTING WITH 00H AND ENDING WITH 60H

Aim5: SIZE OF A BLOCK ENDING WITH THREE ALTERNATE 00H

Aim6: NUMBER OF TIMES FFH OCCURS AS PAIR

Aim7: CONSECUTIVE MEMORY LOCATIONS WITH IDENTICAL DATA

Aim8: COUNT OF SPECIFIED BYTES

Aim9: ADDRESS OF LAST NON-BLANK CHARACTER

Aim10: REPLACING TRAILING ZEROS WITH BLANKS

Aim11: ADDING EVEN PARITY TO ASCII CHARACTERS

5. Name of the Experiment

Sorting

Aim1: SORTING IN DESCENDING ORDER

Aim2: SORTING EVEN AND ODD PARITY BYTES

Aim3: SORTING SIGNED BYTES

Aim4: SORTING SIGNED BINARY BYTES IN ASCENDING ORDER

6. Name of the Experiment

String Operations

Aim1: COMPARISON OF TWO ASCII STRINGS

Aim2: AN ASCII STRING TO BYTE CONVERSION

Aim3: INSERTION TO A LIST

7. Name of the Experiment

Parallel Communication

Aim1: WRITE AN ASSEMBLY LANGUAGE PROGRAM FOR GENERATION OF SQUARE WAVE USING 8255.

Aim2: WRITE AN ASSEMBLY LANGUAGE PROGRAM FOR INPUTTING AN 8-BIT DATA THROUGH PORT A OF 8255 IN MODE – 0

Aim3: WRITE AN ASSEMBLY LANGUAGE PROGRAM FOR INPUTTING AN 8-BIT DATA THROUGH PORT A OF 8255 IN MODE – 1 THROUGH STATUS CHECK.

Aim4: WRITE AN ASSEMBLY LANGUAGE PROGRAM FOR GENERATION OF SQUARE WAVE USING 8253.

Aim5: WRITE AN ASSEMBLY LANGUAGE PROGRAM TO GENERATE TRIANGULAR WAVE USING DAC 0808.

Aim6: WRITE AN ASSEMBLY LANGUAGE PROGRAM TO GENERATE SAW TOOTH WAVE OF MAGNITUDE 0 VOLT TO +4 VOLTS USING DAC 0808.

Aim7: WRITE AN ASSEMBLY LANGUAGE PROGRAM TO CONVERT ANALOG SIGNALS OF MAGNITUDE +3.5 VOLTS TO +5 VOLTS IN STEPS OF 0.1 VOLTS TO DIGITAL EQUIVALENT HEX VALUES.

Aim8: WRITE AN ASSEMBLY LANGUAGE PROGRAM TO CONTROL THE SPEED OF STEPPER MOTOR USING 8255 PPI.

Aim9: WRITE AN ASSEMBLY LANGUAGE PROGRAM TO CONTROL THE TRAFFIC LIGHTS USING 8255 PPI

8. Name of the Experiment

Serial Communication

Aim1: WRITE AN ASSEMBLY LANGUAGE PROGRAM FOR GENERATION OF SQUARE WAVE USING SERIAL OUTPUT PIN

Aim2: WRITE AN ASSEMBLY LANGUAGE PROGRAM FOR INPUTTING AN 8-BIT DATA SERIALLY THROUGH SERIAL INPUT PIN.

9. Name of the Experiment

Interrupts

Aim1: To study the software and hardware interrupts of 8085.

Aim2: To study the Interrupt controller 8259.

Aim3: To study the Interrupt features of 8051.

10. Name of the Experiment Timers

Aim1: WRITE AN ASSEMBLY LANGUAGE PROGRAM TO CALCULATE THE CONVERSION TIME OF ADC USING 8253 TIMER.

Aim2: WRITE AN ASSEMBLY LANGUAGE PROGRAM TO OBSERVE WAVEFORMS OF 8253 TIMER IN DIFFERENT MODES.

11. Name of the Experiment

Keyboard and Display

Aim1: WRITE AN ASSEMBLY LANGUAGE PROGRAM TO FLASH AND ROTATE “HELP US” USING 8259 PIC.

12. Name of the Experiment

Code Conversion

Aim1: BINARY TO BCD CONVERSION

Aim2: BCD TO BINARY CONVERSION

Aim3: CONVERSION OF NIBBLES TO ASCII CODES **Aim4:**

ASCII TO HEXADECIMAL CONVERSION

Books recommended:

Textbooks:

6. Microprocessor Architecture, Programming and Applications with 8085 by R. S. Gaonkar.
7. Advanced Microprocessors and Peripherals by K. M. Bhurchandi and A. K. Ray.
8. The 8051 Microcontroller and Embedded System by Muhammad Ali Mazidi.

Reference books:

4. Intel Manual’s for 8085, 8086, 8051 and other peripheral chips.
5. Advanced Microprocessor” by Y. Rajasree.
6. Microprocessor and Interfacing, Programming of Hardware” by Douglas Hall.

Gaps in the syllabus (to meet Industry/Profession requirements):

POs met through Gaps in the Syllabus: N/A.

Topics beyond syllabus/Advanced topics/Design:

POs met through Topics beyond syllabus/Advanced topics/Design:

Course Outcome (CO) Attainment Assessment Tools and Evaluation Procedure

Direct Assessment

Assessment Tool	% Contribution during CO Assessment
Continuous Internal Assessment	(60)
Attendance Marks	10
Lab file Marks	06
Day-to-day performance Marks	44
End SEM Evaluation	(40)
Lab quiz Marks	08
Lab Viva marks	12
Lab performance Marks	20

Indirect Assessment

1. Student Feedback on Course

Gaps in the syllabus (to meet Industry/Profession requirements): N/A

POs met through Gaps in the Syllabus: N/A

Topics beyond syllabus/Advanced topics/Design:

POs met through Topics beyond syllabus/Advanced topics/Design:

Course Outcome (CO) Attainment Assessment tools & Evaluation procedure

Direct Assessment

Assessment Tool	% Contribution during CO Assessment
Progressive Evaluation	(60)
Attendance Marks	10
Lab file Marks	06
Day-to-day performance Marks	44
End SEM Evaluation	(40)
Lab quiz Marks	08
Lab Viva marks	12
Lab performance Marks	20

Indirect Assessment –

1. Student Feedback on Course Outcome

Mapping of Course Outcomes onto Program Outcomes

Course Outcome	Program Outcomes (POs)												Program Specific Outcomes (PSOs)		
	1	2	3	4	5	6	7	8	9	10	11	12	13	14	15
CO1	3	3	2	3	3	1	1			2		2	2	2	1
CO2	3	3	2	3	3	3	2			2		2	2	2	1
CO3	3	3	2	3	3	3	2			2		2	2	2	1
CO4	3	3	2	3	3	2	2			2		2	2	2	1
CO5	3	3	2	3	3	2	2			2		2	2	2	1

Correlation Levels 1, 2 or 3 as defined below:

1: Slight (Low) 2: Moderate (Medium) 3: Substantial (High)

Mapping Between COs and Course Delivery (CD) methods			
CD	Course Delivery methods	Course Outcome	Course Delivery Method
CD1	Lecture by use of boards/LCD projectors/OHP projectors	CO1	CD5, CD9
CD2	Tutorials/Assignments/Quiz (s)	CO2	CD5, CD9
CD3	Seminars	CO3	CD5, CD9
CD4	Mini projects/Projects	CO4	CD5, CD9
CD5	Laboratory experiments/teaching aids	CO5	CD5, CD9
CD6	Industrial/guest lectures		
CD7	Industrial visits/in-plant training		
CD8	Self- learning such as use of NPTEL materials and internets		
CD9	Simulation		

COURSE INFORMATION SHEET

Signal Processing Techniques

Course Code: EC305 R1

Course Title: Signal Processing Techniques

Pre-requisite(s): Signals and Systems

Co- requisite(s):

Credits: L: 3 T: 1 P: 0

Class schedule per week: 03 Class:

B. Tech.

Semester / Level: 5

Branch: Electronics and Communication Engineering Name

of Teacher:

Course Objectives

This course envisions to impart students to:

1	Understand the basic concepts of signals and system in frequency and Z- domain.
2	Develop transfer function, and structure of digital systems.
3	Develop an ability to design and apply analog filters.
4	Design and implement the digital FIR and IIR filters.
5	Understand the multi-rate signal processing and spectrum estimation.

Course Outcomes

After the completion of this course, students will be able to:

CO1	Study the system representation and characteristics in frequency and Z-transform Domain.
CO2	Design and implement the digital system structures and analyse them.
CO3	Design of analog filters Butterworth filter, Chebyshev filter for various applications.
CO4	Design of digital FIR and IIR filters for various applications.
CO5	Implement multi rate signal processing and spectral estimation.

SYLLABUS

MODULE	(NO. OF LECTURE HOURS)
Module – I Introduction to Discrete-Time signals and system, Difference Equation, Analysis of LTI system in Z-domain, LTI system as frequency selective filter, Inverse system, and de-convolution. Discrete Time Fourier Transform (DTFT) and Discrete Fourier Transform (DFT), Periodic convolution, Fast Fourier Transform (FFT) and its algorithms-Decimation in time and Decimation in frequency.	10
Module – II Digital Filter Structures (FIR & IIR): Direct form I&II, cascade, parallel and ladder realizations, lattice structure, representation of numbers, quantization of filter coefficients, round-off effects.	8
Module – III Filter Function Approximations and Transformations. Review of approximations of ideal analog filter response, Butterworth filter, Chebyshev Type I & II, Elliptic filters. Frequency Transformations: Frequency transformation in analog domain, frequency transformation in digital domain.	8
Module – IV Design of IIR Filter: Design based on analog filter approximations, Impulse invariance method, Matched Z-transformation, Bilinear transformation. Design of FIR Filters: Symmetric and antisymmetric FIR filters, design of linear phase FIR filters using windows and frequency-sampling methods, design of optimum equiripple linear phase FIR filters, comparison of FIR and IIR filters.	8
Module – V Multi rate DSP, Decimators and Interpolators, Sampling rate conversion, multistage decimator & interpolator, Poly phase filters, Estimation of Spectra from Finite-Duration Observations of Signals.	6

Text Books:

1. John G. Proakis, Dimitris G. Marmalakis, Digital Signal Processing, Principles, Algorithms and Applications
2. Alan V. Oppenheim Ronald W. Schaffer, Digital Signal Processing, PHI, India.
3. S. K. Mitra - Digital Signal Processing: A computer based approach, TMH, 2001

Reference Books:

1. Antonious, Digital Filter Design, Mc-Graw-Hill International Editions.

Gaps in the Syllabus (to meet Industry/Profession requirements)

1. Applications of signal processing techniques through hardware platform.

POs met through Gaps in the Syllabus

NA

Topics beyond syllabus/Advanced topics/Design

DSP Processor architectures

POs met through Topics beyond syllabus/Advanced topics/Design

2

Course Outcome (CO) Attainment Assessment Tools & Evaluation Procedure

Direct Assessment

Assessment Tool	% Contribution during CO Assessment
First Quiz	10
Mid Semester Examination	25
Second Quiz	10
Teacher's Assessment	5
End Semester Examination	50

Indirect Assessment

1. Students' Feedback on Course Outcome.

Mapping of Course Outcomes onto Program Outcomes

Course Outcome	Program Outcomes (POs)												Program Specific Outcomes (PSOs)		
	1	2	3	4	5	6	7	8	9	10	11	12	13	14	15
CO1	3	3		2	1				1	1	1	2			
CO2	3	3		2	2				1	2	1	2			
CO3	2	3		2	3				1	1	1	2			
CO4	3	3		2	3				1	1	1	2			
CO5	3	2	1	1	2				1	1	1	2			

Correlation Levels 1, 2 or 3 as defined below:

1: Slight (Low) 2: Moderate (Medium) 3: Substantial (High)

Mapping Between COs and Course Delivery (CD) methods

CD Code	Course Delivery Methods	Course Outcome	Course Delivery Method Used
CD1	Lecture by use of Boards/LCD Projectors	CO1	CD1, CD7, CD 8
CD2	Tutorials/Assignments	CO2	CD1 and CD9
CD3	Seminars	CO3	CD1, CD2 and CD3
CD4	Mini Projects/Projects	CO4	CD1 and CD2
CD5	Laboratory Experiments/Teaching Aids	CO5	CD1 and CD2
CD6	Industrial/Guest Lectures		
CD7	Industrial Visits/In-plant Training		
CD8	Self- learning such as use of NPTEL Materials and Internets		
CD9	Simulation		

COURSE INFORMATION SHEET

Signal Processing Lab

Course Code: EC306

Course Title: Signal Processing Lab

Pre-requisite(s): Signals & Systems Co-requisite(s):

Credits: L: 3 T: 1 P: 0

Class schedule per week: 03 Class:

B. Tech.

Semester / Level: 5

Branch: Electronics and Communication Engineering Name of Teacher:

Course Objectives

This course envisions to impart students to:

1	Understand the basics of Signal Processing algorithms such as convolution and correlation via MATLAB implementation.
2	Design system and analyse its characteristics in transform domain.
3	Design of FIR and IIR filters.
4	Develop skill for MATLAB code and its implementation in DSP processor.
5	Apply the signal Processing techniques in various applications.

Course Outcomes

After the completion of this course, students will be able to:

CO1	Demonstrate understanding of MATLAB with signal processing perspective.
CO2	Design digital system and analyse its characteristics in transform domain.
CO3	Design and implement FIR and IIR filters.
CO4	Apply the knowledge of MATLAB to various set of signal processing problems.
CO5	Develop and apply the signal Processing Algorithms in various applications.

SYLLABUS

Experiments	(NO. OF Sessional Classes)
<p>List of Compulsory experiments:</p> <ol style="list-style-type: none"> 1. Familiarization with MATLAB. Generation of the following sequence and to plot them using MATLAB: <ol style="list-style-type: none"> a. Unit Sample Sequence $\delta[n]$ b. Unit Step Sequence $u[n]$ c. Ramp Sequence $n \cdot u[n]$ d. Exponential Sequences e. Sine / Cosine Sequences 2. To generate the discrete time signal from analog signal using sampling theorem and analyse the aliasing effect. 3. Verification of the following general properties of LTI system. <ol style="list-style-type: none"> a. Linearity b. Time-invariance 4. Computation of the linear convolution of two finite-length sequences. Compare your result with that obtained by theoretical evaluation. 5. To compute the auto correlation/cross-correlation of two finite-length sequences. Compare your result with that obtained by theoretical evaluation. 6. Obtain Inverse Z-Transforms using the Partial Fraction Expansion and test its stability. 7. Cascade realization of the Linear-Phase FIR/ IIR transfer functions using MATLAB. 8. Find out the output of two Periodic Digital sequences using Circular Convolution. Compare your result with that obtained by theoretical evaluation. 9. Computation of N-point DFT and FFT of the length-N sequence using MATLAB and implement using TMS DSP processor. 10. Design of digital filter (LP/HP/BP) and evaluate its performance. 11. To realize the decimation, interpolation and sampling rate conversion of a signal. 12. To write a program and simulate using C language / assembly language for computation of Linear Convolution using TMS DSP Processor 	<p>12</p>

<p>List of Optional experiments:</p> <ol style="list-style-type: none"> 1. To develop a MATLAB program to convert Analog to Digital Frequencies using Bilinear Transformation. 2. To design a Butterworth filter using standard design steps (for LP, HP, BP & BR filters), i.e. find out the order of the filter when Pass Band Gain, Sampling frequency and Pass Band and Stop Band Cut-Off frequencies are given. Then find out the Normalized Transfer Function and Actual Transfer Function 3. To design a Chebyshev filter using standard design steps (general programs for LP, HP, BP & BR filter design) 	<p>8</p>
---	-----------------

Text Books:

1. Getting Started with MATLAB by RudraPratap, Oxford Publication
2. Digital Signal Processing: A computer-Based Approach by Sanjit K. Mitra, Mc-graw Hill
3. Digital Signal Processor: Architecture, Programming and Applications by B. Venkataramani and M. Bhaskar, Tata Mc-graw Hill

Reference Books:

1. Digital Signal Processing using Matlab by Vinay K. Ingle and John J. Proakis, Cengage Learning.

Gaps in the Syllabus (to meet Industry/Profession requirements)

NA

POs met through Gaps in the Syllabus

Topics beyond syllabus/Advanced topics/Design

Through experiments involving design/modelling of device/circuits on advanced topics

POs met through Topics beyond syllabus/Advanced topics/Design

Course Outcome (CO) Attainment Assessment Tools & Evaluation Procedure

Direct Assessment

Assessment Tool	% Contribution during CO Assessment
Progressive Evaluation	(60)
Attendance Marks	12
Lab file Marks	12

Viva Marks	24
Day-to-day performance Marks	12
End SEM Evaluation	(40)
Lab quiz Marks	20
Lab performance Marks	20

Mapping of Course Outcomes onto Program Outcomes

Course Outcome	Program Outcomes (POs)												Program Specific Outcomes (PSOs)		
	1	2	3	4	5	6	7	8	9	10	11	12	13	14	15
CO1	1	2		3	3				1	2		3			
CO2	2	2		3	3				1	2		3			
CO3	2	2		3	3				1	2		3			
CO4	1	2		3	3				1	2		3			
CO5	1	2		3	3				1	2		3			

Correlation Levels 1, 2 or 3 as defined below:

1: Slight (Low) 2: Moderate (Medium) 3: Substantial (High)

Mapping Between COs and Course Delivery (CD) methods

CD Code	Course Delivery Methods	Course Outcome	Course Delivery Method Used
CD1	Lecture by use of Boards/LCD Projectors	CO1	CD5
CD2	Tutorials/Assignments	CO2	CD5
CD3	Seminars	CO3	CD5
CD4	Mini Projects/Projects	CO4	CD5
CD5	Laboratory Experiments/Teaching Aids	CO5	CD5
CD6	Industrial/Guest Lectures		
CD7	Industrial Visits/In-plant Training		
CD8	Self- learning such as use of NPTEL Materials and Internets		
CD9	Simulation		

COURSE INFORMATION SHEET
Control Systems

Course Code: EC307 R1

Course title: Control Systems

Pre-requisite(s): EC205 Signals and Systems

Co- requisite(s):

Course type: Core

Credits: L: 3 T: 0 P: 0

Class schedule per week: 03

Class: B.E

Semester / Level: VII/IV

Branch: ECE

Name of Teacher:

Course Objectives

This course envisions to impart to students to:

1	Basic understanding of control system and its types.
2	Represent any Linear system to using transfer function concept.
3	Explain the concept of system modelling.
4	Explain the time domain analysis to understand the behavior of linear system/Nonlinear system.
5	Analyze the system using Frequency domain approach.

Course Outcomes

After the completion of this course, students will be able to:

CO1	Basic understanding of control system and its types.
CO2	Represent any Linear system to using transfer function concept.
CO3	Explain the concept of system modelling.
CO4	Explain the time domain analysis to understand the behavior of linear system/Nonlinear system.
CO5	Analyze the system using Frequency domain approach.

SYLLABUS

MODULE	(NO. OF LECTURE HOURS)
<p>MODULE – I Introduction:, Examples of control systems and applications, Basic components of control systems, Open loop and closed loop control systems, Effect of feedback on overall gain, Stability and external disturbances, Classification of control system : Linear and nonlinear continuous and digital, Time invariant and time varying, Minimum phase and non-minimum phase systems etc. Linearization of nonlinear systems using Taylor’s series.</p>	6
<p>Module – II Control System Components and Basic Control Actions: Sensors and encoders in control system, Potentiometer, Tachometers, incremental encoders, Synchros, Block Diagrams and Signal Flow Graph: Block diagrams of control systems, Block diagram reduction, Signal Flow Graph (SFG) - Basic properties of SFG, SFG algebra, Gain formula to SGP, Application of gain formula to block diagrams.</p>	10
<p>Module – III Time Response of Control Systems: Transient and steady state response, Time response specifications, typical test signals, Steady state error, and error constant, Stability- Absolute, relative and conditional stability, Dominant poles of transfer function. Root Locus Methods: Root locus concept, Properties and construction of root locus, Determination of relative stability from root locus, Root sensitivity to parameter variation, Root contours, Systems with transportation lag and effect of adding poles or zeros.</p>	8
<p>Module – IV Concepts of State, State Variables: Development of state-space models. State and state equations, State equations from transfer function Transfer function from state equations, State transition matrix, Solution of State equation, Transfer Matrix, State variables and linear discrete time systems, Controllable and observable State models, Asymptotic state observers. Control system design via pole placement. Design of P, PI, PD and PID controllers.</p>	10
<p>Module – V Bode Analysis and Introduction to Design: Frequency response specifications, Correlation between time and frequency domain Bode plot, Determination of stability using Bode plot, Introduction to compensation design using Bode plot. Other Frequency Domain Tools: Nyquist stability criterion, Theory of Magnitude phase plot, Constant M, constant N circle and Nichols chart.</p>	6

Text Books:

1. I. J. Nagrath & Gopal, "Control Systems Engineering", 4th Edition New Age International Publication.
2. K. Ogata, "Modern Control Engineering", 3rd Edition, Pearson Education.

Reference Books:

1. Norman Nise, "Control System Engineering, 4th Edition, Wiley.
2. Graham C. Goodwin, "Control System Design", PHI.
3. B. C. Kuo, "Automatic Control System", 7th Edition, PHI.

Gaps in the syllabus (to meet Industry/Profession requirements): N/A

POs met through Gaps in the Syllabus:

Topics beyond syllabus/Advanced topics/Design:

POs met through Topics beyond syllabus/Advanced topics/Design:

Course Outcome (CO) Attainment Assessment Tools & Evaluation Procedure

Direct Assessment

Assessment Tool	% Contribution during CO Assessment
First Quiz	10
Mid Semester Examination	25
Second Quiz	10
Teacher's Assessment	5
End Semester Examination	50

Indirect Assessment

1. Students' Feedback on Course Outcome.

Mapping of Course Outcomes onto Program Outcomes

Course Outcome	Program Outcomes (POs)												Program Specific Outcomes (PSOs)		
	1	2	3	4	5	6	7	8	9	10	11	12	13	14	15
CO1	2	2	3	3	2	3	1	2	3	3	3	3	3	3	2

CO2	2	2	3	3	2	3	1	2	3	3	3	3	3	3	2
CO3	2	2	3	3	2	3	1	3	3	3	3	3	3	3	2
CO4	2	2	3	3	2	3	1	2	3	3	3	3	3	3	2
CO5	1	1	1	1	1	1	1	1	1	1	2	1	3	3	2

Correlation Levels 1, 2 or 3 as defined below:

1: Slight (Low) 2: Moderate (Medium) 3: Substantial (High)

Mapping Between COs and Course Delivery (CD) methods

CD Code	Course Delivery Methods	Course Outcome	Course Delivery Method Used
CD1	Lecture by use of Boards/LCD Projectors	CO1	CD1, and CD 8
CD2	Tutorials/Assignments	CO2	CD1, and CD 8
CD3	Seminars	CO3	CD1, and CD 8
CD4	Mini Projects/Projects	CO4	CD1, and CD 8
CD5	Laboratory Experiments/Teaching Aids	CO5	CD1, and CD 8
CD6	Industrial/Guest Lectures		
CD7	Industrial Visits/In-plant Training		
CD8	Self- learning such as use of NPTEL Materials and Internets		
CD9	Simulation		

COURSE INFORMATION SHEET
VLSI Systems

Course code: EC319 R1

Course title: VLSI Systems

Pre-requisite(s): EC101 Basics of Electronics & Communication Engineering, EC201 Electronic Devices Co- requisite(s):

Credits: L: 3 T: 0 P: 0 C: 3

Class schedule per week: 03 Class:

B. Tech.

Semester / Level: V/03

Branch: ECE Name

of Teacher:

Course Objectives

This course enables the students to:

1.	Understand the static and dynamic behavior of MOSFET and CMOS inverter.
2.	Interpret the interconnect routing issues, interconnection problems and solutions in integrated circuits and apply the perceived knowledge.
3.	Appraise and analyse the characteristics of combinational logic gates in CMOS.
4.	Design and Evaluate the characteristics of sequential logic circuits.
5.	Create the NMOS/CMOS gain stages for desired gains and analyze their frequency responses.

Course Outcomes

After the completion of this course, students will be able to:

CO1	Describe and illustrate the static and dynamic behavior of MOSFET and CMOS inverter.
CO2	Sketch interconnect parasitics. Explain the interconnect routing issues, interconnection problems and solutions in Integrated Circuit.
CO3	Diagram and explain the combinational logic circuits and illustrate their characteristics and analyse them.
CO4	Schematize the sequential logic circuits, assess their characteristics and summarize their features.
CO5	Design the NMOS/CMOS gain stages for desired gains, schematize their frequency responses and analyze them.

SYLLABUS

MODULE	(NO. OF LECTURE HOURS)
<p>Module – I Static and dynamic behavior of MOSFET and CMOS inverter: The MOS(FET) Transistor: Static Conditions, Dynamic Behavior, Secondary Effects. Static and Dynamic Behaviour of CMOS Inverter: Switching Threshold, Noise Margin formulation, Computing the Capacitances, Propagation Delay, Power, Delay, Power-Delay Product, Energy-Delay Product.</p>	8
<p>Module – II The Wire and Interconnection: Interconnect Parameters, Electrical Wire Models, Capacitive Parasitics, Resistive Parasitics, Inductive Parasitics, Advanced Interconnect Techniques, I/O structures Design: VDD and VSS pads, output & input pads, tri-state and bidirectional pads, application of Schmitt trigger in I/O pads, MOSIS I/O pads, Mixed-Voltage I/O pad.</p>	8
<p>Module – III Designing Combinational Logic Gates in CMOS: Static CMOS Design: Complementary CMOS, Ratioed Logic, Pass-Transistor Logic (PTL), Complementary pass-transistor logic (CPL), Dynamic CMOS Design and issues, Domino logic and issues, np-CMOS, Introduction to the SPICE, Verilog, SystemVerilog with Design examples of inverter, NAND and NOR gates.</p>	8
<p>Module – IV Designing Sequential Logic Circuits: Latches and Registers, Dynamic Latches and Registers, Alternative Register Styles: Pulse Registers, Sense-Amplifier Based Registers; Pipelining: Latch-versus Register-Based Pipelines, NORA-CMOS—A Logic Style for Pipelined Structures; Nonbistable Sequential Circuits, Design examples of latch, flip-flop and register using Verilog, System Verilog HDL.</p>	8
<p>Module – V Basic NMOS/CMOS gain stages and their frequency responses: MOS Amplifier Topologies, Biasing, Realization of Current Sources, CS Core, CS stage With Resistive Load, Current-Source Load, and Diode-Connected Load, CS Stage with Source Degeneration, CG Stage with Biasing, Source Follower with Biasing, Cascode Stage as a Current Source, Cascode Stage as an Amplifier; general frequency response.</p>	8

Textbooks:

1. Jan M. Rabaey, A. Chandrakasan, B. Nikolic, "Digital Integrated Circuits: A Design Perspective", 2nd ed., Prentice Hall, 2003.
2. Neil H. E. Weste, David Money Harris, "CMOS VLSI Design – A Circuits and Systems Perspective," 4th ed., Addison Wesley, 2011.
3. Neil H. E. Weste, David Money Harris, "CMOS VLSI Design – A Circuits and Systems Perspective," 3rd ed., Pearson Education, 2006.

Reference books:

2. Behzad Razavi, "Fundamentals of Microelectronics," Wiley, 2009.
3. Samir Palnitkar, "Verilog HDL: A guide to Digital Design and Synthesis," SunSoft Press, 1996.
4. Stuart Sutherland, Simon Davidmann, Peter Flake, "SystemVerilog Design - A Guide to Using SystemVerilog for Hardware Design and Modeling," 2nd ed., Springer, 2006.

Gaps in the syllabus (to meet Industry/Profession requirements):

1. Hands-on-practical for CMOS IC (Integrated Circuit) fabrication.

POs met through Gaps in the Syllabus:

10

Topics beyond syllabus/Advanced topics/Design:

1. Memory and RF circuits.

POs met through Topics beyond syllabus/Advanced topics/Design:

1. N/A

Course Outcome (CO) Attainment Assessment Tools and Evaluation Procedure

Direct Assessment

Assessment Tool	% Contribution during CO Assessment
First Quiz	10
Mid Semester Examination	25
Second Quiz	10
Teacher's Assessment	5
End Semester Examination	50

Indirect Assessment

1. Students' Feedback on Course Outcome.

Mapping of Course Outcomes onto Program Outcomes

Course Outcome	Program Outcomes (POs)												Program Specific Outcomes (PSOs)		
	1	2	3	4	5	6	7	8	9	10	11	12	13	14	15
CO1	3	3	2	3	3	1	1			3		3	3	2	1
CO2	3	3	2	3	3	3	2			3		3	3	2	1
CO3	3	3	2	3	3	3	2			3		3	3	2	1
CO4	3	3	2	3	3	2	2			3		3	3	2	1
CO5	3	3	2	3	3	2	2			3		3	3	2	1

Correlation Levels 1, 2 or 3 as defined below:

1: Slight (Low) 2: Moderate (Medium) 3: Substantial (High)

Mapping Between COs and Course Delivery (CD) methods

CD Code	Course Delivery Methods	Course Outcome	Course Delivery Method Used
CD1	Lecture by use of Boards/LCD Projectors	CO1	CD1, CD7, CD 8
CD2	Tutorials/Assignments	CO2	CD1 and CD9
CD3	Seminars	CO3	CD1, CD2 and CD3
CD4	Mini Projects/Projects	CO4	CD1 and CD2
CD5	Laboratory Experiments/Teaching Aids	CO5	CD1 and CD2
CD6	Industrial/Guest Lectures		
CD7	Industrial Visits/In-plant Training		
CD8	Self- learning such as use of NPTEL Materials and Internets		
CD9	Simulation		

COURSE INFORMATION SHEET
VLSI Systems Lab

Course code: EC320 R1

Course title: VLSI Systems Lab

Pre-requisite(s): EC101 Basics of Electronics & Communication Engineering, EC201 Electronic Devices

Co- requisite(s): EC319 VLSI Systems

Credits: L: 0 T: 0 P: 3 C: 1.5

Class period per week: 03 **Class:**

B. Tech.

Semester / Level: V/03

Branch: ECE **Name**

of Teacher:

Course Objectives

This course enables the students to:

1.	Understand the structural, behavioural, data-flow models for digital circuits simulation.
2.	Apply their understanding to design digital circuits/universal gates and draw layout of the same.
3.	Analyse the MOS device characteristics and its model parameters.
4.	Integrate basic blocks to build a bigger module and evaluate the results.
5.	Create/develop digital and analog subsystems keeping design goals in consideration.

Course Outcomes

After the completion of this course, students will be able to:

CO1	Translate/express their theoretical knowledge while modelling/designing the basic digital circuits using HDL and Xilinx ISE and observe and explain the simulation results.
CO2	Write HDL RTL codes for designing digital circuits, simulate HDL RTL codes, and observe/examine the results. Interpret the same for the correctness of their functionality. Sketch layouts of universal gates. Simulate and observe/examine the results. Interpret the same for the correctness of their functionality. Apply appropriate bias to the terminals of an nMOSFET/pMOSFET. Simulate and show the output and transfer curves. Determine various MOSFET parameters.
CO3	Outline a VHDL/Verilog model and write RTL codes for Moore/Mealy machines and digital circuits. Test for their operation and analyse the results.
CO4	Evaluate a properly biased short-channel nMOSFET and test it for the short-channel effects.

CO5	Design 2-input NAND gate using SCMOS and pseudo-nMOS logic families and design a 2-input XOR using symbols of 2-input SCMOS NAND gate to achieve design goal. Simulate the designs, test and validate the results. Design/develop single-stage and two-stage CMOS amplifiers. Simulate the design, test and validate the anticipated gain / frequency response.
-----	---

SYLLABUS

Lab is the application of the theory (i.e., hands-on experiments related to the course contents). Therefore, **EC319 VLSI Systems** is the syllabus for the **EC320 VLSI System Lab**. Following experiments are the guidelines for the students. However, the questions for exams are not limited to this experiment list.

List of compulsory experiments:

1. Outline a model of seven-segment decoder to display HEX digits and translate the same into VHDL/Verilog/SystemVerilog RTL code. Simulate the design and find errors, if any. Observe and show the results.
2. Sketch/draw layouts of 2-input CMOS NAND gate and 2-input CMOS NOR gate by the direct translation of their schematics. Perform DRC (design rule checking) on the dawn layout and find design rule errors, if any. Simulate and observe/examine the results. Interpret the same for the correctness of their functionality.
3. Outline a VHDL/Verilog model and write RTL code for a Moore machine with the following state transition diagram. Simulate/compile the same using the Xilinx development software (**Xilinx ISE 8.1i/10.1i**) and find errors, if any. Test for its operation and analyse the results.

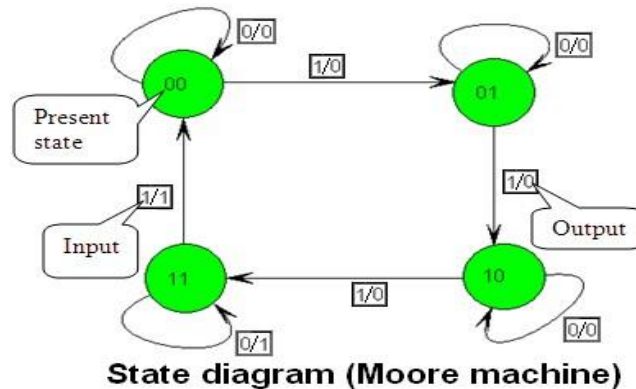

4. Outline a VHDL/Verilog model and write RTL code for a Mealy machine with the following state transition diagram. Simulate/compile the same using the Xilinx development software (**Xilinx ISE 8.1i/10.1i**) and find errors, if any. Test for its operation and analyse the results.

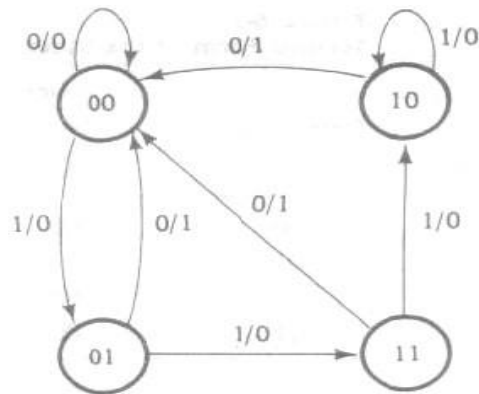

State diagram (Mealy machine)

5. Write a VHDL/Verilog/SystemVerilog RTL code to develop a tri-stated buffer controlled 4channel multiplexer with each channel carrying 4 signals. Simulate/compile the same using the Xilinx development software (**Xilinx ISE 8.1i./10.1i**) and find errors, if any. Test and evaluate the obtained results.
6. Write VHDL/Verilog/SystemVerilog RTL code and develop/design an adder that adds three 8-bit binary number. Simulate using the Xilinx development software (**Xilinx ISE 8.1i./10.1i**) and find errors, if any, test and validate its operation.
7. Apply appropriate bias voltages to the terminals of an nMOSFET/pMOSFET. Change the bias voltage & simulate using Virtuoso Analog Design Environment of Cadence and show the $I_D V_D$ and $I_D - V_G$ curves. Determine MOSFET parameters: r_{on} , μ_n , μ_p , g_m , g_{ds} , C_{gb} , C_{gs} , C_{gd} , V_{tn} , and V_{tp} .
8. Evaluate a properly biased short-channel nMOSFET and test it for the short-channel effects: channel length modulation (CLM), drain-induced barrier lowering (DIBL), V_t rolloff using Virtuoso ADE of Cadence.
9. Design 2-input NAND gate using SCMOS and pseudo-nMOS logic families with given specifications with the Virtuoso ADE of Cadence and design a 2-input XOR using symbols of 2-input SCMOS NAND gate to achieve propagation delay (t_p) not longer than 20 ns and average power consumption (P_{avg}) not higher than 10 μ W. Simulate the designs, test and validate your anticipation. Simulate and report the propagation delay (t_p) and power consumption (P_{avg}) of your XOR gate. Load the input and output of XOR gate with singlestage NAND to make the input and output realistic.
10. Design a common source (CS) amplifier using an nMOSFET (Q_1) with a small-signal gain of at least 3 with respect to ground with the Virtuoso ADE of Cadence. Implement the load current with current source I_{DC} and pMOSFET current mirror, input device of which is Q_3 and output device of which is Q_2 . Simulate the design, test and validate the anticipated gain.
11. Design an inverting differential amplifier with a gain of at least 3 with respect to ground using the Virtuoso ADE of Cadence. Simulate the design, test and validate the anticipated gain.
12. Design an Op Amp based square wave generator with a frequency of at least 1 MHz using the Virtuoso ADE of Cadence. Simulate the design, test and validate the anticipated frequency response.

List of optional experiments:

13. Write a VHDL/Verilog/SystemVerilog model and prepare a Linear-Feedback Shift Register (LFSR). Use the same to develop a Pseudo Random Sequence Generator (PRSG). Simulate and examine the results. Interpret the same for the correctness of its functionality. CO2
14. Write a VHDL/Verilog/SystemVerilog model and develop a Fibonacci LFSR with characteristic polynomial of $1 + x + x^4$. Simulate it with the seed test pattern = 1000 and prepare a table with the results. Interpret the same for its correctness. CO2
15. Write a VHDL/Verilog/SystemVerilog model and develop an 8-bit barrel shifter. Simulate it with the seed test pattern = 11000110 and prepare a table and record the results for consecutive 8 clock pulses. Examine the same for its correctness. CO2
16. Draw the layout of an inverter with donut (round transistor) connection on Microwind 2.6a. Show the advantage of donut connection compared to the layout that is drawn by the direct translation of its schematic.
17. Draw the layout of 2-input NAND gate that has less drain area connected to the output node and show how this layout improves gate performance compared to the layout that is drawn by the direct translation of its schematic.
18. Draw the optimized layout of a 4-input domino AND gate to improve its performance and show how this layout improves gate performance compared to the layout that is drawn by the direct translation of its schematic.
19. Draw the layout of 2-input NOR gate that has less drain area connected to the output and show how this layout improves gate performance compared to the layout that is drawn by the direct translation of its schematic.
20. Write a VHDL/Verilog/SystemVerilog model and develop a 4:1-bit multiplexer. Simulate and synthesize the CPLD design using the Xilinx development software (Xilinx ISE 8.1i.) and find errors, if any. Create the CPLD configuration bitstream file (*.jed), use Spartan-2 CPLD Trainer Kit and download CPLD design (using the iMPACT programming software and the JTAG cable) onto it, demonstrate and interpret the results displayed on the kit.CO2
21. Develop a VHDL/Verilog/SystemVerilog model and design a parameterized N-bit parity generator circuit. The model should provide both an odd parity and an even parity output. Simulate and compile/synthesize the FPGA design using the Xilinx development software, create the FPGA configuration bitstream file (*.bit), download FPGA design (using the iMPACT programming software and the USB cable) onto the prototyping kit (use Spartan-3E FPGA Starter Kit), test and validate its operation. CO5
22. Write a VHDL/Verilog model and develop a 4×16 decoder. Simulate the design using the Xilinx development software (Xilinx ISE 8.1i/10.1i) and find errors, if any. Observe/examine the results. Interpret the same for the correctness of their functionality.
23. Outline a model of 4-bit ripple carry full adder and translate/express the same into VHDL/Verilog RTL code. Simulate/compile the same using the Xilinx development software (Xilinx ISE 8.1i./10.1i) and find errors, if any. Observe and show the results and explain the same.
24. Outline a VHDL/Verilog model and write RTL code for a synchronous counter` with the following states. Simulate/compile the same using the Xilinx Integrated Synthesis Environment (ISE) 8.1i./10.1i) and find errors, if any. Test for its operation and analyse the results.

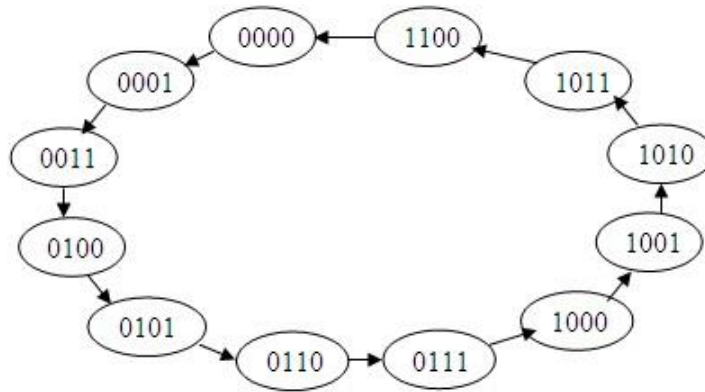

Textbooks:

4. Jan M. Rabaey, A. Chandrakasan, B. Nikolic, “Digital Integrated Circuits: A Design Perspective”, 2nd ed., Prentice Hall, 2003.
5. Neil H. E. Weste, David Money Harris, “CMOS VLSI Design – A Circuits and Systems Perspective,” 4th ed., Addison Wesley, 2011.
6. Neil H. E. Weste, David Money Harris, “CMOS VLSI Design – A Circuits and Systems Perspective,” 3rd ed., Pearson Education, 2006.

Reference books:

5. Behzad Razavi, “Fundamentals of Microelectronics,” Wiley, 2009.
6. Samir Palnitkar, “Verilog HDL: A guide to Digital Design and Synthesis,” SunSoft Press, 1996.
7. Stuart Sutherland, Simon Davidmann, Peter Flake, “SystemVerilog Design - A Guide to Using SystemVerilog for Hardware Design and Modeling,” 2nd ed., Springer, 2006.

Gaps in the syllabus (to meet Industry/Profession requirements):

1. Hands-on-practical for CMOS IC (Integrated Circuit) fabrication.

POs met through Gaps in the Syllabus:

10.

Topics beyond syllabus/Advanced topics/Design:

1. Memory and RF circuits.

POs met through Topics beyond syllabus/Advanced topics/Design:

10

Course Outcome (CO) Attainment Assessment Tools and Evaluation Procedure

Direct Assessment

Assessment Tools	% Contribution during CO Assessment
Continuous Internal Assessment	60

Semester End Examination	40
--------------------------	----

Continuous Internal Assessment	% Distribution
Day to day performance & Lab files	30
Quiz(zes)	10
Viva	20

Semester End Examination	% Distribution
Examination Experiment Performance	30
Quiz	10

Indirect Assessment

1. Students' Feedback on Course Outcome.

Mapping of Course Outcomes onto Program Outcomes

Course Outcome	Program Outcomes (POs)												Program Specific Outcomes (PSOs)		
	1	2	3	4	5	6	7	8	9	10	11	12	13	14	15
CO1	3	3	3	3	3	1	1	1		3		3	3	3	2
CO2	3	3	3	3	3	1	1	1		3		3	3	3	2
CO3	3	3	3	3	3	1	1	1		3		3	3	3	2
CO4	3	3	3	3	3	1	1	1		3		3	3	3	1
CO5	3	3	3	3	3	1	1	1		3		3	3	3	1

Correlation Levels 1, 2 or 3 as defined below:

1: Slight (Low) 2: Moderate (Medium) 3: Substantial (High)

Course Delivery Methods

CD1	Lecture by use of boards/LCD projectors/OHP projectors
CD2	Assignments
CD3	Laboratory experiments/Teaching aids/Seminars
CD4	Mini Projects

CD5	Industrial visits/in-plant training
CD6	Self- learning such as use of NPTEL materials and internets
CD7	Simulation

Mapping between Course Outcomes and Course Delivery Method

Course Outcomes	Course Delivery Method
CO1	CD1, CD3, CD6, CD7
CO2	CD1, CD3, CD6, CD7
CO3	CD1, CD3, CD6, CD7
CO4	CD1, CD3, CD6, CD7
CO5	CD1, CD3, CD6, CD7

COURSE INFORMATION SHEET
Data Communication

Course code: EC351 R1

Course title: Data Communication

Pre-requisite(s): basic concepts of communication

Co- requisite(s):

Credits: L: 3 T: 0 P: 0

Class schedule per week: 03

Class: B.E

Semester / Level: VI

Branch: ECE

Name of Teacher:

Course Objectives:

This course enables the students:

A.	To build an understanding of the fundamental concepts of Data Communication
B.	To analyze the performance of different flow control and error control mechanism and implement Error detection and correction scheme.
C.	Find out a suitable multiplexing scheme for effective utilization of the bandwidth.
D.	Implement different routing algorithm on a given network
E.	To justify the need of protocol and standards in data communication

Course Outcomes:

After the completion of this course, students will be:

CO1	Understand the basic concepts of data encoding and data transmission.
CO2	Explain different Data link control techniques like, error detection, correction, flow control and error control.
CO3	Demonstrate different multiplexing schemes and their practical application.
CO4	Compare the performance of different switching techniques.
CO5	Define the protocols and standards used in data communication

SYLLABUS

MODULE	(NO. OF LECTURE HOURS)
<p>Module – I Data Communication Techniques:: Data Communication model, Transmission line Impairments, Channel Capacity, Guided Transmission media, Digital data to Digital Signal, Different encoding schemes like NRZ, Multilevel Binary, Bi phase, Differential Manchester, Scrambling techniques, Self clocking codes, CODEC and MODEM. Synchronous and Asynchronous transmission, Backward and Forward Error Control, Error detection techniques like CRC, Shift register implementation, Error correction, Block Code principles, Hamming distance, Interfacing standards like V.24/EIA-232.F, CCITT-X.21 Interface.</p>	9
<p>Module – II Data Link Control: Line Configurations, Flow Control using Stop and Wait ARQ, Sliding window protocol, Error control using Stop and Wait ARQ, Go-back-to N ARQ, Selective Reject ARQ, Data Link Control Protocol HDLC, Basic characteristics, Frame structure and operation of HDLC, Data transparency control using bit stuffing, Utilization efficiency of a link, Point-to-Point Protocol (PPP), Introduction to LCP, PAP, CHAP, NCP and IPCP.</p>	9
<p>Module – III Multiplexing and switched Network Frequency Division Multiplexing, Carrier standards, Synchronous Time Division Multiplexing, TDM link control, Digital Carrier systems, SONET/SDH, Statistical Time Division Multiplexing, Performance, Cable Modem, ADSL Design, Discrete multitone, xDSL. Comparison of Circuit switching, Message switching and Packet switching techniques, Digital switching concepts like Space division switching, 3-Stage Space division switch, Control Signalling, Common-channel Signalling, TDM Bus switch, TSI switch, Time Multiplexed Switches like STS and TST, Routing in circuit switched networks.</p>	8
<p>Module – IV Packet Switching: Datagram packet switching and Virtual circuit Packet switching, Use of Least cost algorithms like Dijkstra's and Bellman-Ford algorithms, Routing characteristics, Routing strategies, Example system of ARPANET (all 3 generations) Congestion, Congestion control techniques, Traffic management, Congestion control in Packet switched networks, CCITT X.25 Interface.</p>	7
<p>Module – V Protocols : The need for a Protocol Architecture, OSI layered structure, TCP/IP Protocol Suite, Fundamental differences between OSI and TCP/IP, Primitives and PDUs. Network topology, LAN protocol architecture, Function of LLC and MAC. Connecting devices like Repeaters, Hubs, Bridges, Two-layer switches, Routers and Three layer switches. IP header and IP addressing. QoS in internetworking, Transport protocols TCP and UDP.</p>	7

Text Books:

1. Data and Computer Communication, 7/e. by William Stallings.
2. Data Communication and Networking, 3/e. by Behrouz. A. Forouzan.

Reference Books:

1. Data Communication and Computer Networks by Prakash C. Gupta. Prentice Hall India Pvt., Limited

Gaps in the Syllabus (to meet Industry/Profession requirements)

Hardware implementation and testing of encoding techniques, link layer protocols, multiplexing techniques.

POs met through Gaps in the Syllabus

3, 4, 12

Topics beyond syllabus/Advanced topics/Design

- Network Security
- Application Layer protocol

POs met through Topics beyond syllabus/Advanced topics/Design

2, 3, 4, 12

Course Outcome (CO) Attainment Assessment Tools & Evaluation Procedure**Direct Assessment**

Assessment Tool	% Contribution during CO Assessment
First Quiz	10
Mid Semester Examination	25
Second Quiz	10
Teacher's Assessment	5
End Semester Examination	50

Indirect Assessment

1. Students' Feedback on Course Outcome.

Mapping of Course Outcomes onto Program Outcomes

Course Outcome	Program Outcomes (POs)												Program Specific Outcomes (PSOs)		
	1	2	3	4	5	6	7	8	9	10	11	12	13	14	15
CO1	3	1	1	2	1	-	-	-	-	-	-	2	2	1	3
CO2	3	3	3	2	1	-	-	-	-	-	-	1	3	1	3
CO3	3	3	2	2	2	-	-	-	-	-	-	1	2	2	2
CO4	3	2	1	1	1	-	-	-	-	-	-	1	2	2	2
CO5	3	1	1	2	1	-	-	-	-	-	-	2	2	1	3

Correlation Levels 1, 2 or 3 as defined below:

1: Slight (Low) 2: Moderate (Medium) 3: Substantial (High)

Mapping Between COs and Course Delivery (CD) methods

CD Code	Course Delivery Methods	Course Outcome	Course Delivery Method Used
CD1	Lecture by use of Boards/LCD Projectors	CO1	CD1, CD7, CD 8
CD2	Tutorials/Assignments	CO2	CD1 and CD9
CD3	Seminars	CO3	CD1, CD2 and CD3
CD4	Mini Projects/Projects	CO4	CD1 and CD2
CD5	Laboratory Experiments/Teaching Aids	CO5	CD1 and CD2
CD6	Industrial/Guest Lectures		
CD7	Industrial Visits/In-plant Training		
CD8	Self- learning such as use of NPTEL Materials and Internets		
CD9	Simulation		

COURSE INFORMATION SHEET

Digital Communication

Course Code: EC353 R1

Course Title: Digital Communication

Pre-requisite(s): Knowledge of Analog Communication, Probability and Random Signal Theory

Co- requisite(s): NA

Credits: L: 3 T: 0 P: 0 C:3

Class schedule per week: 03

Class: B. Tech.

Semester / Level: Fifth / Third

Branch: Electronics & Communication Engineering

Name of Teacher:

Course Objectives

This course envisions to impart to students to:

6.	To know the principles of sampling, Quantization and various waveform coding schemes.
7.	To learn the various baseband transmission schemes
8.	To learn the different digital modulation techniques
9.	To know the elements of information theory
10.	To know spread spectrum techniques

Course Outcomes

After the completion of this course, students will be able to:

CO1	Demonstrate the concept of sampling, Quantization and various waveform coding schemes
CO2	Apply the concepts of various baseband transmission schemes.
CO3	Design and develop the different digital modulation systems
CO4	Apply the concepts of information theory for digital communication systems
CO5	Apply the concepts of spread spectrum techniques for digital communication systems

SYLLABUS

MODULE	(NO. OF LECTURE HOURS)
<p>Module – I</p> <p>Introduction to digital communication System, Sampling Process, Sampling Theorems for Low Pass and Bandpass Signals, Types of Sampling, Quantization of Signals, Companding, Different Encoding schemes like NRZ, Multilevel Binary, Bi-phase, Differential Manchester, Pulse Code Modulation, Differential Pulse Code Modulation, Delta Modulation and Adaptive Delta Modulation, Noise in Pulse Code Modulation and Delta Modulation Systems.</p>	10
<p>Module – II</p> <p>Matched Filter, Error Rate due to Noise, Intersymbol Interference, Nyquist Criterion for Distortion-less Baseband Binary Transmission, Geometric Representation of Signals, The Gram-Schmidt Orthogonalization Procedure, Maximum Likelihood Decoding, Correlation Receiver.</p>	8
<p>Module – III</p> <p>Digital Modulation Techniques: Amplitude Shift Keying, Binary Phase Shift Keying, Differential Phase Shift Keying, Quadrature Phase Shift Keying, M-ary PSK, Binary Frequency Shift Keying, M-ary FSK, and Minimum Shift Keying. Error Probability and Power Spectra of ASK, BPSK, QPSK and BFSK, Equalization Techniques, Synchronization and Carrier Recovery for Digital modulation.</p>	8
<p>Module – IV</p> <p>The concept of Amount of Information, Entropy, Information Rate, Shannon Fano and Huffman Source Coding Schemes, Shannon’s theorem, Channel capacity, Capacity of Gaussian Channel, Bandwidth-S/N Trade off.</p>	7
<p>Module – V</p> <p>Characteristics and Applications of Spread Spectrum, Direct Sequence Spread Spectrum, Effect of Thermal Noise, Single Tone Interference and Jamming, Code Division Multiple Access, PN Sequence, Frequency Hop Spread Spectrum, Time Hop Spread Spectrum.</p>	7

Text Books:

1. “Principles of Communication Systems”, 4/e, by H. Taub and D L Schilling, Goutam Saha, Tata McGraw Hills, ND.
2. “Communication Systems”, 4/e by Simon Haykin, John Wiley and Sons, Delhi.

3. “Modern Digital and Analog Communication System” 4/e by B.P.Lathi, Zhi Ding, Oxford University Press

Reference Books:

1. Digital Communications Fundamental and Applications by Bernard Sklar, Pearson Education.
2. Proakis J. G. and Salehi M., "Communication Systems Engineering", Pearson Education, 2002.
3. P Ramakrishna Rao, “Digital Communication” TMH Education Private Limited 2011

Gaps in the Syllabus (to meet Industry/Profession requirements) : NA

POs met through Gaps in the Syllabus : NIL

Topics beyond syllabus/Advanced topics/Design:

1. Estimation Theory for Communication System

POs met through Topics beyond syllabus/Advanced topics/Design Po2, Po3, Po4

Course Outcome (CO) Attainment Assessment Tools & Evaluation Procedure

Direct Assessment

Assessment Tool	% Contribution during CO Assessment
First Quiz	10
Mid Semester Examination	25
Second Quiz	10
Teacher’s Assessment	5
End Semester Examination	50

Indirect Assessment

1. Students’ Feedback on Course Outcome.

Mapping of Course Outcomes onto Program Outcomes

Course Outcome	Program Outcomes (POs)												Program Specific Outcomes (PSOs)		
	1	2	3	4	5	6	7	8	9	10	11	12	1	2	3
CO1	3	3	2	3	3	1	1	3	2	2	1	3	3	2	2
CO2	3	3	2	3	3	1	1	3	2	2	1	3	3	2	2
CO3	3	3	2	3	3	1	1	3	2	2	1	3	1	2	3
CO4	3	3	2	3	3	1	1	3	2	2	1	3	3	2	1
CO5	3	3	2	3	3	1	1	3	2	2	1	3	3	2	1

Correlation Levels 1, 2 or 3 as defined below:

1: Slight (Low) 2: Moderate (Medium) 3: Substantial (High)

Mapping Between COs and Course Delivery (CD) methods

CD Code	Course Delivery Methods	Course Outcome	Course Delivery Method Used
CD1	Lecture by use of boards/LCD projectors/OHP projectors	CO1	CD1, CD 8
CD2	Tutorials/Assignments	CO2	CD1, CD 8 and CD9
CD3	Seminars	CO3	CD1, CD4, CD8 and CD9
CD4	Mini projects/Projects	CO4	CD1 and CD8
CD5	Laboratory experiments/teaching aids	CO5	CD1 and CD8
CD6	Industrial/guest lectures		
CD7	Industrial visits/in-plant training		
CD8	Self- learning such as use of NPTEL materials and internets		
CD9	Simulation		

COURSE INFORMATION SHEET
Communication System Lab.

Course code: EC54 R1

Course title: Communication System Lab.

Pre-requisite(s): Analog Communication

Co-requisite(s): Digital Communication

Credits: L: 0 T: 0 P: 3 C: 1.5 Class

schedule per week: 03 Class: B.

Tech.

Semester / Level: Fifth/Three Branch:

Electronics & Communication Lab

Name of Teacher:

Course Objectives:

This course enables the students:

6.	To develop an understanding about the Analog Modulation Techniques, V-F conversion and Butterworth LPF.
7.	To develop an understanding about the signal sampling, quantization and its reconstruction
8.	To develop an ability to understand and design the various waveform coding techniques
9.	To develop an ability to evaluate and design various digital modulation Techniques
10.	To develop an ability to evaluate and design Time Division Multiplexing Technique

Course Outcomes:

After the completion of this course, students will be able to:

CO1	Demonstrate understanding of the various Analog Modulation Techniques, V-F conversion and Butterworth LPF.
CO2	Analyse the signal sampling, quantization and its reconstruction.
CO3	Design the generation and detection of various waveform coding techniques such as PCM, DM and ADM
CO4	Design the modulators and demodulators for various digital modulation techniques such as ASK, PSK, FSK, QPSK, and QAM
CO5	Design system for Time Division multiplexing Technique

SYLLABUS

List of Compulsory experiments:

- 1. Name of the Experiment: Generation and detection of Amplitude Modulated**
AIM-1: Generation and detection of Amplitude Modulated wave and calculation of percentage modulation using ACL 01 and ACL 02 Kits
AIM-2: Design of Amplitude Modulation, DSB-SC, and SCB-SC Modulation and Demodulation Systems using ALTAIR Solid Thinking Embed/Comm.
- 2. Name of the Experiment: : Generation and detection of Frequency Modulated wave**
AIM-1: Generation and detection of Frequency Modulated wave using ACL 03 and ACL 04 FM trainer Kits
AIM-2: Design of Frequency Modulation and Demodulation Systems using ALTAIR Solid Thinking Embed/Comm.
- 3. Name of the Experiment: Generation and detection of PAM, PWM, PPM**
AIM-1: Generation and detection of PAM, PWM, PPM using DCL 08 Falcon kit.
AIM-2: Design of PAM, PWM, PPM Modulation and Demodulation Systems using ALTAIR Solid Thinking Embed/Comm.
- 4. Name of the Experiment: Design and implementation of 2nd and 4th order Low pass Butterworth filters**
AIM-1: Design and implementation of 2nd and 4th order Low pass Butterworth filters using Multisim
AIM-2: Design and implementation of 2nd and 4th order Low pass Butterworth filters
- 5. Name of the Experiment: Investigation of Signal Sampling and Reconstruction**
AIM-1: Investigation of Signal Sampling and Reconstruction using DCL 01 Falcon kit
AIM-2: Investigation of Signal Sampling and Reconstruction using ALTAIR Solid Thinking Embed/Comm
- 6. Name of the Experiment: Investigation of TDM system**
AIM-1: Investigation of TDM system using DCL02 Falcon kit
- 7. Name of the Experiment: Investigation of practical PCM system**
AIM-1: Investigation of practical PCM system using DCL03 and DCL04 Falcon kit
- 8. Name of the Experiment: Investigation of Delta Modulation system**
AIM-1: Investigation of Delta Modulation and Adaptive Delta modulation system using DCL07 Falcon kit
- 9. Name of the Experiment: Investigation of ASK, FSK, PSK modulation/demodulation**
AIM-1: Investigation of ASK, FSK, PSK modulation/demodulation using trainer kits
AIM-2: Design of ASK, PSK, FSK modulator/demodulator using ALTAIR Solid Thinking Embed/Comm

10. Name of the Experiment: Investigation of MSK modulation/demodulation

AIM-1: Investigation of MSK modulation/demodulation using trainer kits

AIM-2: Design of MSK modulator/demodulator using ALTAIR Solid Thinking Embed/Comm

11. Name of the Experiment: Investigation of QAM modulation and demodulation

AIM-1 : Investigation of QAM modulation and demodulation using ST 2112 QAM trainer kit

AIM-2: Design of QAM modulator/demodulator using ALTAIR Solid Thinking Embed/Comm

12. Name of the Experiment: Investigation of QPSK modulation and demodulation

AIM-1: Investigation of QPSK modulation and demodulation using ST 2112 QAM trainer kit

AIM-2: Design of QPSK modulator/demodulator using ALTAIR Solid Thinking Embed/Comm

Text Book:

1. “Principles of Communication Systems”, 2/e, by H. Taub and DL Schilling, Tata McGraw Hills, ND.
2. “Communication Systems”, 4/e by Simon Haykin, John Wiley and Sons, Delhi.

Reference Books:

1. Simon Haykin, “Communication Systems”, Wiley Eastern Limited, New Delhi, 2016, 4/e.
2. J. Schiller, “Mobile Communication” 2/e, Pearson Education, 2012.

Gaps in the syllabus (to meet Industry/Profession requirements): NA

POs met through Gaps in the Syllabus: N/A.

Topics beyond syllabus/Advanced topics/Design: N/A

POs met through Topics beyond syllabus/Advanced topics/Design: N/A

Course Outcome (CO) Attainment Assessment tools & Evaluation procedure

Direct Assessment

Assessment Tool	% Contribution during CO Assessment
Progressive Evaluation	(60)
Attendance Marks	12
Day-to-day performance Marks	06
Lab Viva marks	20

Lab file Marks	12
Lab Quiz-I Marks	10
End SEM Evaluation	(40)
Lab Quiz-II Marks	10
Lab performance Marks	30

Indirect Assessment –

1. Student Feedback on Faculty
2. Student Feedback on Course Outcome

Mapping of Course Outcomes onto Program Outcomes

Course Outcome	Program Outcomes (POs)												Program Specific Outcomes (PSOs)		
	1	2	3	4	5	6	7	8	9	10	11	12	1	2	3
CO1	3	3	3	3	3	1	1	1	1	2	1	3	2	2	1
CO2	3	3	3	3	3	1	1	1	1	2	1	3	2	2	1
CO3	3	3	3	3	3	1	1	1	1	2	1	3	2	2	1
CO4	3	3	3	3	3	1	1	1	1	2	1	3	2	2	1
CO5	3	3	3	3	3	1	1	1	1	2	1	3	2	2	1

Correlation Levels 1, 2 or 3 as defined below:

1: Slight (Low) 2: Moderate (Medium) 3: Substantial (High)

Mapping Between COs and Course Delivery (CD) methods:

CD Code	Course Delivery Methods	Course Outcome	Course Delivery Method Used
CD1	Lecture by use of Boards/LCD Projectors	CO1	CD1, CD5
CD2	Tutorials/Assignments	CO2	CD1, CD5
CD3	Seminars/ Quiz (s)	CO3	CD1, CD5
CD4	Mini Projects/Projects	CO4	CD1, CD5

CD5	Laboratory Experiments/Teaching Aids	CO5	CD1, CD5
CD6	Industrial/Guest Lectures		
CD7	Industrial Visits/In-plant Training		
CD8	Self- learning such as use of NPTEL Materials and Internets		
CD9	Simulation		

COURSE INFORMATION SHEET

Fiber Optic Communication Lab

Course code: **EC352**

Course title: Fiber Optic Communication Lab

Pre-requisite(s): Basic Electronic Engineering, Analog Circuits

Co- requisite(s):

Credits: L: 0 T: 0 P: 3 C: 1.5

Class periods per week: 03 Class: B. Tech.

Semester / Level: VI

Branch: ECE Name of

Teacher:

Course Objectives

This course enables the students to:

1.	Demonstrate fiber optic analog link and digital link without and with multiplexing.
2.	Illustrate fiber attenuation, coupling losses and numerical measurement.
3.	Inspect different modulation format in fiber optic link.
4.	Design of optical fiber and characterize optical amplifier.
5.	Realize wavelength division multiplexing and de-multiplexing in fiber optic link.

Course Outcomes

After the completion of this course, students will be able to:

CO1	Design single mode and multimode fiber, and measure fiber parameters.
CO2	Choose the modulation techniques for the short haul and long haul fiber optic link.
CO3	Apply multiplexing techniques, and coding schemes in analog and digital fiber optic link.
CO4	Design and characterize the optical amplifier.
CO5	Design modulator based on Mach-Zehnder interferometer

Syllabus

Hands-on experiments related to the course: Fiber Optic Communication.

Experiment No.	Name of the Experiments
1.	Setting up a fiber optic Analog link and setting up a fiber optic Digital link using LED source. AIM1: Setting up a fiber optic Analog link AIM2: Setting up a fiber optic Digital link

2.	Measurement of fiber attenuation of a plastic fiber Measurement of Numerical Aperture (NA) of a multimode fiber. AIM1: Measurement of fiber attenuation. AIM2: Measurement of Numerical Aperture (NA).
3.	Realization of PWM and PPM in fiber optic link. AIM1: Realization of PWM in fiber optic link. AIM2: Realization of PPM in fiber optic link.
4.	Realization of Analog Time Division Multiplexing in fiber optic link. AIM: Realization of Analog Time Division Multiplexing in fiber optic link.
5.	Realization of Digital Time Division Multiplexing and study of framing in fiber optic link. AIM1: Realization of Digital Time Division Multiplexing in fiber optic link. AIM2: Study of framing in fiber optic link.
6.	Manchester Coding and Decoding in optical fiber link. AIM: Study of Manchester Coding and Decoding in optical fiber link.
7.	Measurement of Bit Error Rate (BER) and study of Eye Pattern. AIM1: Measurement of Bit Error Rate (BER) in fiber optic link. AIM2: Study of Eye Pattern.
8.	Realization of Wavelength Division Multiplexing and De-multiplexing in fiber optic communication system. AIM: Realization of Wavelength Division Multiplexing and De-multiplexing in fiber optic communication system.
9.	Excitation of LP modes (LP_{01} , LP_{11} , LP_{02}) and to find their power distributions in the Core and Cladding of optical fiber using Beam-Prop (RSoft) software. AIM: Excitation of LP modes (LP_{01} , LP_{11} , LP_{02}) and to find their power distributions in the Core and Cladding of optical fiber.
10.	Implementation of a Mach-Zehnder electro-optic modulator and plotting of the Power Output vs. Applied Voltage using Beam-Prop (RSoft) software. AIM: Implementation of a Mach-Zehnder electro-optic modulator and plotting of the Power Output vs. Applied Voltage.
11.	Implementation of technique of Manchester Coding and Decoding in optical fiber link using Optisystem (Optiwave) software. AIM: Implementation of technique of Manchester Coding and Decoding in optical fiber link.
12.	Characterization of Erbium Doped Fiber Amplifier (EDFA). AIM1: Setting up the fiber optic link with EDFA. AIM2: Measurement of Gain of EDFA.

Text books:

T1. "Optical Fiber Communications" G.Keiser, 3/e, McGraw Hill **Ref.**

Books:

R1. "Introduction to Fiber Optics", Ghatak&Thyagarajan, Cambridge University Press.

Gaps in the syllabus (to meet Industry/Profession requirements):

POs met through Gaps in the Syllabus:

Topics beyond syllabus/Advanced topics/Design: through experiments involving design/modelling of device/circuits on advanced topics

POs met through Topics beyond syllabus/Advanced topics/Design: through experiments involving design/modelling of device/circuits on advanced topics

Course Delivery Methods

CD1	Lecture by use of boards/LCD projectors/OHP projectors
CD2	Assignments
CD3	Laboratory experiments/teaching aids/Seminars
CD4	Industrial/guest lectures
CD5	Industrial visits/in-plant training
CD6	Self- learning such as use of NPTEL materials and internets
CD7	Simulation

Course Outcome (CO) Attainment Assessment tools & Evaluation procedure

Direct Assessment

Assessment Tool	% Contribution during CO Assessment
Attendance	12
Day to Day Performance	6
Viva	20
Lab Journal	12
Quiz	10
Sub Total	60
<i>End-Sem Evaluation 40%</i>	
Examination Experiment Performance*	30
Quiz	10
Sub total	40
Grand Total	100

Assessment Components	CO1	CO2	CO3	CO4	CO5
Progressive Evaluation	3	3	3	3	3
End SEM Evaluation	3	3	3	3	3

If satisfying < 34% = 1, 34-66% = 2, > 66% = 3

Indirect Assessment

1. Student Feedback on Faculty
2. Student Feedback on Course

Mapping between Course Outcomes and Program Outcomes

Mapping of Course Outcomes onto Program Outcomes

Course Outcome	Program Outcomes (POs)												Program Specific Outcomes (PSOs)		
	1	2	3	4	5	6	7	8	9	10	11	12	13	14	15
CO1	3	3	3	3	3	1	1	1		1		1	2	3	2
CO2	3	3	3	3	3	1	1	1		1		1	1	2	3
CO3	3	3	3	3	3	1	1	1		3		3	1	2	3
CO4	3	3	3	3	3	1	1	1		3		3	2	2	3
CO5	3	3	3	3	3	1	1	1		3		3	3	2	2

< 34% = 1, 34-66% = 2, > 66% = 3

Mapping between Course Outcomes and Course Delivery Method

Course Outcomes	Course Delivery Method
CO1	CD3, CD7
CO2	CD3, CD7
CO3	CD3, CD7
CO4	CD3, CD7
CO5	CD3, CD7

COURSE INFORMATION SHEET
Microwave Theory and Techniques

Course code: EC401 R1

Course title: Microwave Theory and Techniques

Pre-requisite(s): EC257 Electromagnetic Fields and Waves Co- requisite(s): EC324 Microwave Engineering Lab.

Credits: L: 3 T: 0 P: 0 C: 3

Class schedule per week: 03 Class:

B. Tech.

Semester / Level: V/03

Branch: ECE

Name of Teacher:

Course Objectives

This course enables the students to:

6.	To appraise the requirements of Microwave engineering
7.	To develop ability to analyse microwave networks.
8.	To describe and analyse the operation of Microwave sources and amplifiers.
9.	To differentiate, describe, design, and analyse the active and passive microwave components
10.	To differentiate, describe, design, and analyse reciprocal and nonreciprocal components

Course Outcomes

After the completion of this course, students will be able to:

CO1	To describe the characteristics and applications of microwave engineering
CO2	To define microwave network theories and analyse the various microwave networks.
CO3	To design, characterize and describe microwave sources and amplifiers.
CO4	To differentiate, describe, design and analyse the active and passive microwave components
CO5	To differentiate, describe, design and analyse reciprocal and nonreciprocal components

SYLLABUS

MODULE	(NO. OF LECTURE HOURS)
Module – I Introduction to Microwave and Microwave Network Analysis: Microwave Frequency bands, Applications of Microwaves, Equivalent Voltages and currents, Impedance and Admittance Matrices, Scattering Parameters, The Transmission (ABCD) Matrix.	8
Module – II Passive Microwave Devices and Components: Basic Properties of Dividers and Couplers, The T-Junction Power Divider, Wilkinson Power Divider, Waveguide Directional Couplers, Quadrature (90°) Hybrid, Coupled Line Directional Couplers.	8
Module – III Microwave Tubes: Limitations and Losses of conventional Tubes at Microwave Frequencies, Klystron, Travelling Wave Tube, Magnetron	8
Module – IV Microwave Filters: Filter Types and parameters, Realization of Butterworth and Chebyshev type filter, Filter Implementation.	8
Module – V Design of Ferromagnetic Components: Intro to Ferromagnetic Material, Faraday rotation in ferrite, Ferrite Isolators, Ferrite Phase Shifters, Ferrite Circulators.	8

Books recommended:

Textbooks:

1. David M. Pozar, "Microwave Engineering", Third Edition, Wiley India.

Reference books:

1. S. Y. Liao , “Microwave Devices & Circuits”, PHI 2nd Edition
2. R. Ludwig and G. Bogdanov, “RF Circuit Design, Theory and Applications”, Pearson, 2nd Edition.
3. B. R. Vishvakarma, R U Khan, M K. Meshram, “ Introduction to Microwave Measurements”
4. R.E.Collin, "Foundations for Microwave Engineering", Second edition, IEEE Press.

Gaps in the syllabus (to meet Industry/Profession requirements): Hands on experience on realtime industrial projects and management

POs met through Gaps in the Syllabus: PO11

Topics beyond syllabus/Advanced topics/Design: EMI-EMC due to electromagnetic radiations

POs met through Topics beyond syllabus/Advanced topics/Design: PO 6, PO 8

Course Outcome (CO) Attainment Assessment Tools and Evaluation Procedure

Direct Assessment

Assessment Tool	% Contribution during CO Assessment
First Quiz	10
Mid Semester Examination	25
Second Quiz	10
Teacher's Assessment	5
End Semester Examination	50

Indirect Assessment

1. Students' Feedback on Course Outcome.

Mapping of Course Outcomes onto Program Outcomes

Course Outcome	Program Outcomes (POs)												Program Specific Outcomes (PSOs)		
	1	2	3	4	5	6	7	8	9	10	11	12	13	14	15
CO1	3	2		1	1		1	1	1	1	1	3			
CO2	3	3	3	3	3	1	1	1	2	2	1	3			
CO3	3	3	3	3	3	1	1	1	2	2	1	3			
CO4	3	3	2	3	3	1	1	1	2	2	1	3			
CO5	3	3	2	3	3	1	1	1	2	2	1	3			

Correlation Levels 1, 2 or 3 as defined below:

1: Slight (Low) 2: Moderate (Medium) 3: Substantial (High)

Mapping between COs and Course Delivery (CD) methods

CD Code	Course Delivery Methods	Course Outcome	Course Delivery Method Used
CD1	Lecture by use of Boards/LCD Projectors	CO1	CD1, CD2, CD8
CD2	Tutorials/Assignments	CO2	CD1, CD2, CD4,CD5, CD8
CD3	Seminars	CO3	CD1, CD2, CD4, CD5, CD8
CD4	Mini Projects/Projects	CO4	CD1, CD2, CD4, CD5, CD8
CD5	Laboratory Experiments/Teaching Aids	CO5	CD1, CD2, CD4,CD5, CD8
CD6	Industrial/Guest Lectures		
CD7	Industrial Visits/In-plant Training		
CD8	Self- learning such as use of NPTEL Materials and Internets		
CD9	Simulation		

COURSE INFORMATION SHEET
Microwave Lab

Course code: EC402 R1

Course title: Microwave Lab

Pre-requisite(s): Electromagnetic Fields and Waves Co- requisite(s):

Credits: L: 0 T: 0 P: 3 C: 1.5 Class

schedule per week: 03 Class: B. Tech.

Semester / Level: Fifth/Three

Branch: Electronics & Communication Engineering

Name of Teacher: ALL

Course Objectives:

This course enables the students:

11.	To develop an understanding about the measurements of the various microwave passive components.
12.	To develop an understanding about the measurements of the performance parameters of Microwave Crystal Detector and Gunn Diode.
13.	To develop an ability to understand a planar microwave filter.
14.	To develop an ability to understand a planar microwave coupler .
15.	To develop an ability to understand a microstrip planar power divider

Course Outcomes:

After the completion of this course, students will be able to:

CO1	Demonstrate understanding of the measurements of the various microwave passive components.
CO2	Demonstrate understanding of the measurements of the performance parameters of Microwave Crystal Detector and Gunn Diode.
CO3	Design a planar microwave filter.
CO4	Design a planar microwave coupler and power divider
CO5	Design a microstrip planar power divider

Syllabus

List of Compulsory experiments:

1. Name of the Experiment: Rectangular Waveguide

AIM-1: To Determine the Rectangular Waveguide Parameters

2. Name of the Experiment: Waveguide T-Junctions

AIM-1: To Find out the Coupling Coefficients of E-plane and H-plane Tee.

3. Name of the Experiment: Magic Tee

AIM-1: To Find out the Coupling Coefficients and Isolation of Magic Tee

4. Name of the Experiment: Multi Hole Direction Coupler

AIM-1: To Find out the Coupling Factor, Directivity and Insertion Loss of a Multi Hole Direction Coupler

5. Name of the Experiment: Three Port Circulator

AIM-1: To Find out the Coupling Coefficients and Isolation of a three port Circulator

6. Name of the Experiment: Phase Shifter

AIM 1: To Find out the Isolation of an Isolator and amount of phase shift of a phase shifter

7. Name of the Experiment: Variable Attenuator

AIM 1: To Determine the Attenuation of a Variable Attenuator

8. Name of the Experiment:, Design of rectangular micro strip patch antenna using IE3D

AIM 1: To Examine the square law characteristics of a Microwave Crystal Detector

9. Name of the Experiment: Microstrip Low Pass Filter

AIM 1: Using the IE3D, Design a low pass filter whose input and output are matched to a 50Ω impedance and that meets the following specifications: cut-off frequency of 3 GHz, equiripple of 0.5 dB, and rejection of at least 25 dB at approximately 1.5 times the cut-off frequency. Assume a dielectric material that results in a phase velocity of 60 % of the speed of light.

10. Name of the Experiment:, Branch-line Quadrature Hybrid Junction

AIM 1: Using the IE3D, Design a 50Ω branch-line quadrature hybrid junction, and plot the scattering parameter magnitudes from $0.5f_0$ to $1.5f_0$ where f_0 is the design frequency.

11. Name of the Experiment:, Microstrip Power Divider

AIM 1: Using the IE3D, Design a 3 dB equal power divider and plot the scattering parameter magnitudes from $0.5f_0$ to $1.5f_0$ where f_0 is the design frequency

List of Optional experiments:**1. Name of the Experiment:, X-band Pyramidal Horn Antenna**

AIM 1: To Determine the Power gain, Radiation Pattern and 3dB Beamwidth of a X-band Pyramidal Horn Antenna

2. Name of the Experiment:, KU- band Pyramidal Horn Antenna

AIM 1: To Determine the Power gain, Radiation Pattern and 3dB Beamwidth of a KU-band Pyramidal Horn Antenna.

3. Name of the Experiment:, Microstrip Antenna

AIM 1: To Determine the Power gain, Radiation Pattern and 3dB Beamwidth of a Microstrip patch Antenna.

4. Name of the Experiment:, Parabolic Disc Antenna

AIM 1: Measurement of Power gain, Radiation Pattern and 3dB Beamwidth of a Parabolic Disc Antenna.

5. Name of the Experiment:, Coaxial Line

AIM 1: To Find out the Frequency and line parameters for a coaxial line.

6. Name of the Experiment:, VHF Transmission Line

AIM 1: To Find out the frequency and line Parameters of a two wire VHF transmission line.

Text Book:

1. "David M. Pozar, "Microwave Engineering", Third Edition, Wiley India.

Reference Books:

1. S. Y. Liao , "Microwave Devices & Circuits", PHI 2nd Edition
2. R. Ludwig and G. Bogdanov, "RF Circuit Design, Theory and Applications", Pearson, 2nd Edition.
 2. B. R. Vishvakarma, R U Khan, M K. Meshram, " Intoduction to Microwave Measurements"
3. R.E.Collin, "Foundations for Microwave Engineering", Second edition, IEEE Press.

Gaps in the syllabus (to meet Industry/Profession requirements): NA

POs met through Gaps in the Syllabus: N/A.

Topics beyond syllabus/Advanced topics/Design: N/A

POs met through Topics beyond syllabus/Advanced topics/Design: N/A

Course Outcome (CO) Attainment Assessment tools & Evaluation procedure

Direct Assessment

Assessment Tool	% Contribution during CO Assessment
Progressive Evaluation	(60)
Attendance Marks	12
Day-to-day performance Marks	06
Lab Viva marks	20
Lab file Marks	12
Lab Quiz-I Marks	10
End SEM Evaluation	(40)
Lab Quiz-II Marks	10
Lab performance Marks	30

Indirect Assessment –

1. Student Feedback on Faculty
2. Student Feedback on Course Outcome

Mapping of Course Outcomes onto Program Outcomes

Course Outcome	Program Outcomes (POs)												Program Specific Outcomes (PSOs)		
	1	2	3	4	5	6	7	8	9	10	11	12	1	2	3
CO1	3	3	1	1	3	1	-	-	1	3	1	2	2	2	1
CO2	3	3	1	1	3	1	-	-	1	3	1	2	2	2	1
CO3	3	3	3	2	3	1	-	-	1	3	1	3	2	2	1
CO4	3	3	3	2	3	1	-	-	1	3	1	3	2	2	1
CO5	3	3	3	2	3	1	-	-	1	3	1	3	2	2	1

Correlation Levels 1, 2 or 3 as defined below:

- 1: Slight (Low) 2: Moderate (Medium) 3: Substantial (High)

Mapping Between COs and Course Delivery (CD) methods:

CD Code	Course Delivery Methods	Course Outcome	Course Delivery Method Used
CD1	Lecture by use of Boards/LCD Projectors	CO1	CD1, CD5 ,CD8
CD2	Tutorials/Assignments	CO2	CD1, CD5,CD8
CD3	Seminars/ Quiz (s)	CO3	CD1, CD5,CD8, CD9
CD4	Mini Projects/Projects	CO4	CD1, CD5, CD9
CD5	Laboratory Experiments/Teaching Aids	CO5	CD1, CD5, CD9
CD6	Industrial/Guest Lectures		
CD7	Industrial Visits/In-plant Training		
CD8	Self- learning such as use of NPTEL Materials and Internets		
CD9	Simulation		

COURSE INFORMATION SHEET

Advanced Communication Lab

Course code: EC404 R1

Course title: Advanced Communication Lab

Pre-requisite(s): Knowledge of digital, data and mobile cellular communication

Co- requisite(s): N/A

Credits: L: 0 T: 0 P: 3

Class schedule per week: 03

Class: B. Tech

Semester / Level: VI

Branch: ECE

Name of Teacher:

Course Objectives

This course enables the students:

1	To understand the concept of PN sequence, Gold Code, Convolutional encoding and Viterbi decoding.
2	To understand the different wireless technologies like Wi-Fi, ZigBee and RFID.
3	To understand the concept of GPS and Survey plotting.
4	To understand the impact of various factors, like: Transmitter Power, path loss exponent, carrier frequency, receiver antenna height, transmitter antenna height on received signal strength.
5	To understand the concept of AWGN Channel and handover mechanism and different generations of mobile and cellular communication systems

Course Outcomes:

After the completion of this course, students will be able to:

CO1	Explain about the application of PN sequence and gold codes and convolutional encoding and decoding.
CO2	Explain the different wireless technologies like Wi-Fi, ZigBee and RFID.
CO3	Explain the procedure of graphical representation of geographical position using Survey Plotting and GPS link establishment
CO4	Explain the impact of various factors, like: Transmitter Power, path loss exponent, carrier frequency, receiver antenna height, transmitter antenna height on received signal strength.
CO5	Evaluate the impact of path loss and shadowing in estimation of received signal power

Syllabus

List of Experiments:

Compulsory Experiments:

1. Study the PN sequence and examine Gold Code with variable sequence length and analyse its correlation. Also perform the spreading of input binary data and corresponding de-spreading using DSSS scheme in CDMA trainer kit.
2. Set up a link between GPS satellite and GPS trainer kit, and measure the present position using GPS system. Also study the graphical representation of geographical position using Survey Plotting.

3. Study and test the functioning of various applications using RFID system.
4. Configure ZigBee module as an end device and set up a communication link with two ZigBee modules.
5. Study the AT commands related to modem information, phone book and sending SMS using mobile trainer kit.
6. Understanding 3G mobile communication using AT commands on 3G trainer kit.
7. Perform the convolutional encoding and hard decision Viterbi decoding for $K = 7$ and rate $\frac{1}{2}$. Also compare the corresponding result with soft decision Viterbi decoding.
8. Setup the WLAN system and perform study of pure ALOHA and slotted ALOHA protocols using WLAN.
9. Study the behaviour of AWGN samples captured from the Wi-Guy inbuilt SDR receiver.
10. Decoding of the LTE signal using Wi-Guy inbuilt SDR receiver.
11. Evaluate the impact of path loss and shadowing in estimation of received signal power in mobile cellular communication using virtual lab for fading channels and mobile communications.
12. Demonstrate the impact of the received power levels for hand-offs in case of mobile cellular communication using virtual lab for fading channels and mobile communications.

Optional Experiments:

1. Study the GPRS system and use it for sending an email through Wi-GPRS trainer.
2. Study of how to control devices over TCP/IP using Wi-Fi trainer kit.
3. Understanding 4G mobile communication and fault evaluation on 4G trainer kit.
4. Set up the 4G Network using 5-Nine Radio and its signal measurement.

Text Book:

1. Vijay K. Garg, “Wireless Communications and Networks”, Morgan Kaufmann Publishers an Imprint of Elsevier, USA 2009 (Indian reprint).

Reference Books:

1. Simon Haykin, “Communication Systems”, Wiley Eastern Limited, New Delhi, 2016, 4/e.
2. J. Schiller, “Mobile Communication” 2/e, Pearson Education, 2012.

Gaps in the syllabus (to meet Industry/Profession requirements): To know emerging industrial requirements

POs met through Gaps in the Syllabus: PO5

Topics beyond syllabus/Advanced topics/Design: design of antenna with different configuration can be done

POs met through Topics beyond syllabus/Advanced topics/Design: PO2

Course Delivery methods

S. No.	
CD1	Lecture by use of boards/LCD projectors/OHP projectors
CD2	Quizzes
CD3	Assignments/Seminars
CD4	Mini projects/Projects
CD5	Laboratory experiments/teaching aids
CD6	Industrial/guest lectures
CD7	Industrial visits/in-plant training
CD8	Self- learning such as use of NPTEL materials and internets
CD9	Simulation

Course Outcome (CO) Attainment Assessment tools & Evaluation procedure

Direct Assessment

Assessment Tool		% Contribution during CO Assessment	
Progressive Evaluation	Attendance Marks	12	60
	Lab file Marks	12	
	Viva Marks	24	
	Day-to-day performance Marks	12	
End SEM Evaluation	Lab quiz Marks	20	40
	Lab performance Marks	20	
Total		100	

Assessment Components	CO1	CO2	CO3	CO4
Progressive Evaluation				
End SEM Evaluation				

If satisfying < 34% = 1, 34-66% = 2, > 66% = 3

Indirect Assessment

1. Student Feedback on Faculty
2. Student Feedback on Course Outcome

Mapping between Course Outcomes and Program Outcomes

Mapping of Course Outcomes onto Program Outcomes

Course Outcome #	Program Outcomes											
	PO1	PO2	PO3	PO4	PO5	PO6	PO7	PO8	PO9	PO10	PO11	PO12
CO1	3	3	-	-	3	-	-	-	-	3	-	1
CO2	3	3	-	-	3	-	-	-	-	3	-	1
CO3	3	3	3	-	3	-	-	-	-	3	-	1
CO4	3	3	3	-	3	-	-	-	-	3	-	1
CO5	3	3	1	-	3	-	-	-	-	3	-	1

If satisfying < 34% = 1, 34-66% = 2, > 66% = 3

Mapping between Course Outcomes and Course Delivery method

Course Outcomes	Course Delivery Method
CO1	CD1, CD2, CD6, CD8
CO2	CD1, CD2, CD6, CD8
CO3	CD1, CD2, CD6, CD8
CO4	CD1, CD2, CD6, CD8, CD9
CO5	CD1, CD2, CD6, CD8

COURSE INFORMATION SHEET
Industrial Automation Lab

Course code: **EC406 R1**

Course title: **Industrial Automation Lab**

Pre-requisite(s): Electronic Measurement, Sensor and transducers,

Co- requisite(s): Electronic measurement Lab

Credits: L: 0 T: 0 P: 3

Class schedule per week: 03 Class:

B. Tech.

Semester / Level: 03

Branch: ECE Name

of Teacher:

Course Objectives

This course enables the students to:

1.	To provide exposure to various measuring techniques for flow, level, vibration etc.
2.	To demonstrate the working of different actuators.
3.	To introduce virtual instrumentation with Lab VIEW software.
4.	To program PLC for different real time control application.
5.	To demonstrate various controllers parameter tuning.

Course Outcomes

After the completion of this course, students will be able to:

CO1	Demonstrate the measuring techniques for flow, level, vibration etc.
CO2	Actuate control signal using different actuators for controlling valves.
CO3	Able to design measuring instruments using Lab VIEW software.
CO4	Program PLC for given real time application.
CO5	Schematize various control loop for industrial application.

SYLLABUS

List of experiments:

1. Name of the Experiment

FLOW MEASUREMENT

Aim1. Flow Measurement using orifice, U tube Manometer and Rotameter.

2. Name of the Experiment

FLOW CONTROL LOOP

Aim1. Liquid flow control using Flow control loop trainer.

3. Name of the Experiment

VIBRATION MEASUREMENT

Aim1. Displacement Velocity and Acceleration measurement using Piezoelectric acceleration sensor.

4. Name of the Experiment

PNEUMATIC TRAINER

Aim1. Perform actuations using Pneumatic Actuator Trainer.

5. Name of the Experiment

PRESSURE CONTROL LOOP

Aim1. Pneumatic Pressure control using Pressure control loop trainer.

6. Name of the Experiment

LEVEL CONTROL LOOP

Aim1. Liquid Level control using Level control loop trainer

7. Name of the Experiment I to P CONVERTOR

Aim1. Study of current to pressure converter.

8. Name of the Experiment PLC-I

Aim1. Lift control using ABB PLC

9. Name of the Experiment PLC-II

Aim1. Logic gate simulation on ABB PLC.

10. Name of the Experiment

PRESSURE GAUGE TESTER

Aim1. Calibration of pressure instruments using dead weight pressure gauge tester.

11. Name of the Experiment LabVIEW-I

Aim1. Design of function generator using LabVIEW.

12. Name of the Experiment LabVIEW-II

Aim1. Design of CRO using Lab VIEW

Books recommended:

Textbooks:

3. “Computer-Based Industrial Control”, by Krishna Kant, PHI.
4. “Process Control Instrumentation Technology”, by Curtis D Johnson, Pearson Ed.

Reference books:

2. “Sensors and Transducers”, 2/E by D. Patranabis

Gaps in the syllabus (to meet Industry/Profession requirements): Visit CIF lab at BIT Mesra.

POs met through Gaps in the Syllabus: N/A.

Topics beyond syllabus/Advanced topics/Design: N/A

POs met through Topics beyond syllabus/Advanced topics/Design: N/A

Course Outcome (CO) Attainment Assessment Tools and Evaluation Procedure

Direct Assessment

Assessment Tools	% Contribution during CO Assessment
Continuous Internal Assessment	60
Semester End Examination	40

Continuous Internal Assessment	% Distribution
Day to day performance & Lab files	30
Quiz(zes)	10
Viva	20

Semester End Examination	% Distribution
Examination Experiment Performance	30
Quiz	10

Indirect Assessment

1. Student Feedback on Course

Mapping of Course Outcomes onto Program Outcomes

Course Outcome	Program Outcomes (POs)												Program Specific Outcomes (PSOs)		
	1	2	3	4	5	6	7	8	9	10	11	12	1	2	3
CO1	3	3	3	3	3	1	1	1	1	1		1	2	2	1
CO2	3	3	3	3	3	1	1		1	1		1	2	2	1
CO3	3	3	3	3	3	1	1		1	1		1	2	2	1
CO4	3	3	3	2	2	1	1		1	1			2	2	1
CO5	3	3	3	3	3	1	1	1	1	1		1	2	2	1

Correlation Levels 1, 2 or 3 as defined below:

1: Slight (Low) 2: Moderate (Medium) 3: Substantial (High)

Mapping Between COs and Course Delivery (CD) methods

CD Code	Course Delivery Methods	Course Outcome	Course Delivery Method Used
CD1	Lecture by use of Boards/LCD Projectors	CO1	CD5
CD2	Tutorials/Assignments	CO2	CD5
CD3	Seminars	CO3	CD5, CD9
CD4	Mini Projects/Projects	CO4	CD5, CD9
CD5	Laboratory Experiments/Teaching Aids	CO5	CD5, CD8
CD6	Industrial/Guest Lectures		
CD7	Industrial Visits/In-plant Training		
CD8	Self- learning such as use of NPTEL Materials and Internets		
CD9	Simulation		

COURSE INFORMATION SHEET

Fiber Optic Communication

Course code: **EC355 R1**

Course title: **Fiber Optic Communication**

Pre-requisite(s): Knowledge of Semiconductor Devices, Electromagnetic Theory

Co-requisite(s): None

Credits: L: 3 T: 0 P: 0 C: 3

Class schedule per week: 03

Class: B. Tech

Semester / Level: 06

Branch: ECE

Name of Teacher:

Course Objectives

This course enables the students:

1.	To demonstrate the different generations, elements required to establish the fiber optic link, the losses and the dispersion effects in fiber optic communication.
2.	To identify the types of couplers, optical sources for fiber optic communication system.
3.	To identify the types of photodiode, optical receivers in fiber optic communication system and understand system performance through the link power budget and dispersion limitations of digital fiber optic link.
4.	To understand WDM, optical amplifiers, optical switching in fiber optic networks.
5.	To understand different network topologies and nonlinear effects in fiber optic communication.

Course Outcomes

After the completion of this course, students will be able to:

CO1	Identify the elements required to establish the fiber optic link and determine the losses and the dispersion effects in fiber optic communication.
CO2	Choose the appropriate couplers, optical sources for fiber optic communication system.
CO3	Select the types of photodiodes/optical receivers in fiber optic communication system and assess the system performance through the link power budget and dispersion limitations of digital fiber optic link.
CO4	Implement the WDM, optical amplifiers, optical switching for fiber optic networks.
CO5	Analyze the different network topologies and nonlinear effects in fiber optic communication.

Syllabus

MODULE	(NO. OF LECTURE HOURS)
<p>Module – I</p> <p>Generations of optical communication, Basic elements of an optical fiber transmission link, Fiber types and fiber parameters, Fiber material and fabrication methods, Ray and modal analysis in Step Index (SI) and Graded index (GI) fibers, Modes in SI&GI fibers, Power flow in step index fibers, Attenuation mechanisms in optical fibers, Dispersion effects in optical fibers.</p>	10
<p>Module – II</p> <p>Structure and materials of LED and LD sources, Operating characteristics and modulation capabilities of the LED and LD sources, Source to Fiber Power launching and coupling, Lensing scheme for coupling improvement, Fiber to fiber coupling and alignment methods, Splicing techniques, Fiber Connectors.</p>	10
<p>Module – III</p> <p>Principle of PIN photodiode and Avalanche photodiode, Noise in photodetectors, Detector response time, Photodiode materials, Optical receiver configuration and performance, Pre-amplifier design for optical receiver, analog and digital receiver. Optical link design - BER calculation, quantum limit, power penalties, Point to point transmission links, Link power and rise time budget.</p>	7
<p>Module – IV</p> <p>WDM and DWDM operational principles, Optical couplers, Fiber Bragg grating, AWG router/multiplexer, Add/Drop Multiplexer, Optical amplifiers, Amplification mechanism of semiconductor optical amplifier(SOA) and Erbium doped fiber amplifier (EDFA), EDFA architecture, Optical switches, Wavelength converters.</p>	8
<p>Module – V</p> <p>SONET/ SDH architecture, SONET/ SDH Rings, All optical WDM networks, Single hop and multihop networks, Nonlinear effects on network performance, SRS, SBS, Self-phase modulation(SPM), Soliton pulses, Soliton based communication.</p>	5

Text books:

1. “Optical Fiber Communications” G.Keiser, 3/e, McGraw Hill
2. “Optical Fiber Communication”, J. M. Senior, PHI, 2nd Ed.
3. “Optical Networking and WDM”, Walter Goralski, Tata McGraw-Hill

Ref. Books:

1. “Introduction to Fiber Optics”, Ghatak & Thyagarajan, Cambridge University press.
2. “Optical Communications”, J.H.Franz & V.K.Jain Narosa Publishing House.
3. “Fiber Optics Communication”, Harold Kolimbris, Pearson Education.

4. “Fundamentals of Fiber optics in telecommunication and sensor systems”, B.P.Pal, New age International (P) Ltd.
5. “Optical Communication Networks”, B.Mukherjee McGraw Hill.

Gaps in the syllabus (to meet Industry/Profession requirements):

POs met through Gaps in the Syllabus:

Topics beyond syllabus/Advanced topics/Design:

POs met through Topics beyond syllabus/Advanced topics/Design: PO6

Course Delivery Methods

CD1	Lecture by use of boards/LCD projectors/OHP projectors
CD2	Assignments
CD3	Laboratory experiments/teaching aids/Seminars
CD4	Industrial/guest lectures
CD5	Industrial visits/in-plant training
CD6	Self- learning such as use of NPTEL materials and internets
CD7	Simulation

Course Outcome (CO) Attainment Assessment tools & Evaluation procedure

Direct Assessment

Assessment Tool	% Contribution during CO Assessment
Mid Sem Examination Marks	25
End Sem Examination Marks	60
Assignment / Quiz (s)	15

Indirect Assessment

1. Student Feedback on Course Outcome

Mapping between Course Outcomes and Program Outcomes

Course Outcome	Program Outcomes (POs)												Program Specific Outcomes (PSOs)		
	1	2	3	4	5	6	7	8	9	10	11	12	13	14	15
CO1	3	3	2	2	3	1	2		1	2	3	1	3	2	2
CO2	3	3	2	2	3	1	2		1	2	3	2	3	2	2
CO3	3	3	2	3	3	1	2		1	2	3	2	3	2	2
CO4	3	3	2	3	3	2	3	2	2	2	3	2	3	2	3
CO5	3	3	2	3	3	2	3	2	2	2	3	2	3	2	3

Correlation Levels 1, 2 or 3 as defined below:

1: Slight (Low) 2: Moderate (Medium) 3: Substantial (High)

Mapping between Course Outcomes and Course Delivery Method

Course Outcomes	Course Delivery Method
CO1	CD1, CD2, CD3, CD6, CD7
CO2	CD1, CD2, CD3, CD6, CD7
CO3	CD1, CD2, CD3, CD6, CD7
CO4	CD1, CD2, CD3, CD6, CD7
CO5	CD1, CD2, CD3, CD6, CD7

COURSE INFORMATION SHEET
Introduction to Industrial Instrumentation

Course code: EC357 R1

Course title: Introduction to Industrial Instrumentation

Pre-requisite(s): EC208 Electronic Measurements Lab Co-requisite(s):

Credits: L: 3 T: 0 P: 0 C: 3

Class schedule per week: 3x1

Class: B. Tech

Semester / Level: V/03

Branch: ECE Name

of Teacher:

Course Objectives

This course enables the students to:

1.	Understand the role of instrumentation for controlling different electrical or nonelectrical process variables in process industry.
2.	Demonstrate the working of various components of an Automation System.
3.	Summarize the various control schemes used in industry.
4.	Experiment with PLC systems and its programming for controlling industrial processes.
5.	Schematize intelligent controllers for industrial applications.

Course Outcomes

After the completion of this course, students will be able to:

CO1	Reproduce the different working principles of transducers and also design transducers for measurement of non-electrical process variables.
CO2	Explain the role and working of different components of an industrial automation systems.
CO3	Investigate and analyse the various control schemes used in industry.
CO4	Demonstrate the working of PLC and its programming.
CO5	Apply the concept of intelligent controllers as dynamic controller to control the process with dynamic disturbances.

SYLLABUS

MODULE	(NO. OF LECTURE HOURS)
<p>Module – I Review of Transducers: Principles of operations and its classification, Characteristics, Technological trends in making transducers, Silicon sensors for the measurement of pressure, Level, Flow and Temperature, Bio-sensors ,types and its Application .Radiation Sensors, X -ray and Nuclear radiation sensors, Fiber optic sensors for Temperature, Liquid level, Fluid- flow measurement, Electro-analytical sensors: Electrochemical cell, Standard Hydrogen Electrode (SHE), Smart sensors.</p>	10
<p>Module – II Components of Industrial Automation system: Detailed study of each block involved in making of DAS, Signal Conditioners: as DA, IA, Signal Converters (ADC & DAC), Sample and hold, Designing of Pressure, Temperature measuring instrumentation system using DAS, Data logger. Introduction about Automation system, Concepts of Control Schemes, Types of Controllers, Components involved in implementation of Automation system i.e., DAS, DOS, Converter (I to P) and Actuators: Pneumatic cylinder, Relay, Solenoid (Final Control Element).</p>	10
<p>Module – III Control Systems: Concepts of Controllers Schemes, Types of Controllers, Computer Supervisory Control System (SCADA), Direct Digital Control's Structure and Software, Introduction to Distributed Digital Control.</p>	7
<p>Module – IV Programmable Logic Controllers: Introduction of Programmable logic controller, Principles of operation, Architecture of Programmable controllers, Programming the Programmable controller.</p>	8
<p>Module – V Intelligent Controllers: Introduction to Intelligent Controllers, Model based controllers, Predictive control, Artificial Intelligent Based Systems, Experts Controller, Fuzzy Logic System and Controller, Artificial Neural Networks, Neuro-Fuzzy Controller system.</p>	5

Books recommended:

Textbooks:

1. “Computer-Based Industrial Control”, by Krishna Kant, PHI.
2. “Process Control Instrumentation Technology”, by Curtis D Johnson, Pearson Ed.

Reference books: 1. “Sensors and Transducers”, 2/E by D. Patranabis

Gaps in the syllabus (to meet Industry/Profession requirements):

POs met through Gaps in the Syllabus: N/A

Topics beyond syllabus/Advanced topics/Design: N/A

POs met through Topics beyond syllabus/Advanced topics/Design: N/A

Course Outcome (CO) Attainment Assessment Tools & Evaluation Procedure
Direct Assessment

Assessment Tool	% Contribution during CO Assessment
First Quiz	10
Mid Semester Examination	25
Second Quiz	10
Teacher's Assessment	5
End Semester Examination	50

Indirect Assessment

1. Students' Feedback on Course Outcome.

Mapping of Course Outcomes onto Program Outcomes

Course Outcome	Program Outcomes (POs)												Program Specific Outcomes (PSOs)		
	1	2	3	4	5	6	7	8	9	10	11	12	13	14	15
CO1	3	3	2	3	3	1	1			3		3	3	3	1
CO2	3	3	2	3	3	3	2			3		3	3	3	1
CO3	3	3	2	3	3	3	2			3		3	3	3	1
CO4	3	3	2	3	3	2	2			3		3	3	3	1
CO5	3	3	2	3	3	2	2			3		3	3	3	1

Correlation Levels 1, 2 or 3 as defined below:

1: Slight (Low) 2: Moderate (Medium) 3: Substantial (High)

Mapping Between COs and Course Delivery (CD) methods

CD Code	Course Delivery Methods	Course Outcome	Course Delivery Method Used
CD1	Lecture by use of Boards/LCD Projectors	CO1	CD1, CD2, CD7, CD 8
CD2	Tutorials/Assignments	CO2	CD1, CD2, CD7, CD 8
CD3	Seminars	CO3	CD1, CD2, CD7, CD 8
CD4	Mini Projects/Projects	CO4	CD1, CD2, CD7, CD 8
CD5	Laboratory Experiments/Teaching Aids	CO5	CD1, CD2, CD7, CD 8
CD6	Industrial/Guest Lectures		
CD7	Industrial Visits/In-plant Training		
CD8	Self- learning such as use of NPTEL Materials and Internets		
CD9	Simulation		

COURSE INFORMATION SHEET

Information Theory and Coding

Course Code: EC359

Course Title: Information Theory and Coding

Pre-requisite(s): Knowledge of digital electronics, probability theory, basic understanding of communication system.

Co- requisite(s):

Credits: L: 3 T: 0 P: 0 C:3

Class schedule per week: 03 Class:

B. Tech.

Semester / Level: Fifth/Three

Branch: Electronics & Communication Engineering Name of Teacher:

Course Objectives

This course envisions to impart to students to:

1	An understanding of the fundamental knowledge of information
2	An understanding of channel capacity to achieve efficient as well as reliable communication.
3	An understanding of various Source and Channel Coding Techniques
4	Fundamental understanding on block codes, cyclic codes and convolutional codes, also explore its practical challenges.
5	An ability to design and provide solutions for practical low cost, efficient, reliable and secure communication system.

Course Outcomes

After the completion of this course, students will be able to:

CO1	Have an ability to measure information from a discrete as well as continuous source
CO2	Have an ability to compute the capacity of discrete and continuous time channels in presence and absence of noise.
CO3	Have an ability to measure and evaluate entropy for lossy & lossless source coding..
CO4	Have an ability to ensure error free transmission of a discrete/ continuous message source using suitable channel coding techniques like linear block codes, cyclic codes, convolution codes and turbo codes.
CO5	Have an ability to provide practical solutions and apply the subject expertise for the well fare of society

SYLLABUS

MODULE	(NO. OF LECTURE HOURS)
<p>Module – I Source Coding: Information measure, Entropy, Differential Entropy, Conditional Entropy, Relative Entropy, Information rate, Mutual Information, Shannon’s Source Coding Theorem Prefix Coding, Huffman Coding, Shannon-Fano Coding, Arithmetic Coding, Lempel Ziv Algorithm, Rate Distortion Theory.</p>	10
<p>Module – II Channel Capacity & Coding: Channel Coding Theorem, Markov Sources, Discrete Channel with discrete Noise BSC, BEC, Capacity of a Gaussian Channel, channel capacity for MIMO system Bandwidth-S/N Trade-off.</p>	10
<p>Module – III Block Codes: Galois Fields, Hamming Weight and Hamming Distance, Linear Block Code, Encoding and decoding of Linear Block-codes, Parity Check Matrix, Bounds for block codes, Hamming Codes, Syndrome Decoding.</p>	7
<p>Module – IV Cyclic Codes: Introduction to cyclic code, Method for generating Cyclic Codes, Matrix description of Cyclic codes, Cyclic Redundancy Check (CRC) codes, Circuit implementation cyclic codes, Burst error correction, BCH codes.</p>	7
<p>Module – V Convolutional Codes: Introduction to Convolutional Codes, Polynomial description of Convolutional Code, Generating function, Matrix description of Convolutional Codes, Viterbi Decoding Convolutional code, Introduction to Turbo Code, Introduction to Cryptography, Overview of Encryption Techniques.</p>	7

Text Books:

1. “Information Theory, Coding & Cryptography”, by Ranjan Bose, TMH, Second Edition.
2. “Communication Systems”, by S. Haykin, 4th Edition, Wiley-Publication.

Reference Books:

1. “Elements of Information Theory” by Thomas M. Cover, J. A. Thomas, Wiley-Inter science Publication.
2. “Error Correction Coding Mathematical Methods and Algorithms” by Todd K. Moon, Wiley India Edition.
3. “Cryptography and Network Security”, Fourth Edition, by William Stallings

Gaps in the Syllabus (to meet Industry/Profession requirements)**POs met through Gaps in the Syllabus:****Topics beyond syllabus/Advanced topics/Design****POs met through Topics beyond syllabus/Advanced topics/Design: PO1****Course Outcome (CO) Attainment Assessment Tools & Evaluation Procedure****Direct Assessment**

Assessment Tool	% Contribution during CO Assessment
First Quiz	10
Mid Semester Examination	25
Second Quiz	10
Teacher’s Assessment	5
End Semester Examination	50

Indirect Assessment

1. Students’ Feedback on Course Outcome.

Mapping of Course Outcomes onto Program Outcomes

Course Outcome	Program Outcomes (POs)												Program Specific Outcomes (PSOs)		
	1	2	3	4	5	6	7	8	9	10	11	12	13	14	15
CO1	3	1											3	2	1
CO2	3	3				1							3	2	2
CO3	3	3				1							3	2	1
CO4	3	3	1	3		1	1					2	3	2	3
CO5	3	3	1	3		1	1					2	3	2	2

Correlation Levels 1, 2 or 3 as defined below:

1: Slight (Low) 2: Moderate (Medium) 3: Substantial (High)

Mapping Between COs and Course Delivery (CD) methods

CD Code	Course Delivery Methods	Course Outcome	Course Delivery Method Used
CD1	Lecture by use of Boards/LCD Projectors	CO1	CD1, CD8
CD2	Tutorials/Assignments	CO2	CD1 ,CD8
CD3	Seminars	CO3	CD1, CD8
CD4	Mini Projects/Projects	CO4	CD1, CD8
CD5	Laboratory Experiments/Teaching Aids	CO5	CD1,CD8
CD6	Industrial/Guest Lectures		
CD7	Industrial Visits/In-plant Training		
CD8	Self- learning such as use of NPTEL Materials and Internets		
CD9	Simulation		

COURSE INFORMATION SHEET
Mobile and Cellular Communication

Course Code: EC403 R1

Course Title: Mobile and Cellular Communication

Pre-requisite(s): Knowledge of Communication process, probability theory, basic understanding of interference and noise in communication process, basic understanding of communication media.

Co-requisite(s):N/A

Credits: L: 3 T: 0 P: 0 C: 3 **Class**

schedule per week: 03/week

Class: B. Tech.

Semester / Level: Fifth/ Third

Branch: Electronics & Communication Engineering Name of Teacher:

Course Objectives

This course enables the students:

1	To understand cellular concept, cellular architecture and evolution of different generations and standards for mobile cellular communication.
2	To comprehend the impact of interference on the cellular system capacity.
3	To comprehend different channel parameters causing impairments in signal propagation.
4	To understand impairment removal techniques in signal propagation
5	An understanding of multiple access techniques to support mobile cellular communication

Course Outcomes:

After the completion of this course, students will be able to:

CO1	Explain cellular concept, cellular architecture and evolution of different generations and standards for mobile cellular communication.
CO2	Analyze the impact of interference on the cellular system capacity.
CO3	Analyze different channel parameters causing impairments in signal propagation
CO4	Evaluate different methods of Channel impairments removal techniques.
CO5	Explain multiple access techniques to support mobile cellular communication

SYLLABUS

MODULE	(NO. OF LECTURE HOURS)
<p>Module – I The cellular fundamentals: cellular communication and frequency reuse, general architecture of a cellular system, channel assignment strategies, handoff in a cellular system. Evolution of mobile cellular communication: different generations of mobile cellular communication (1G, 2G, 2.5G, 3G and beyond), typical cellular standards (AMPS, GSM, GPRS, WCDMA, LTE, concept of LTE-advanced), 4G features and challenges, 5G vision.</p>	<p>10</p>
<p>Module – II Interference and cellular system capacity: co-channel interference and adjacent channel interference, power control, inter-symbol interference, enhancing cellular system capacity (cell splitting, sectorization, smart antenna technique, link adaptation and small cell deployment).</p>	<p>8</p>
<p>Module – III Signal propagation in mobile communication : mobile cellular environment, multipath propagation and fading, free space propagation model, propagation path loss, outdoor propagation models (Okumura model & Hata model), indoor propagation models, power delay profile, channel parameters (delay spread, doppler spread, coherence bandwidth, coherence time, LCR and ADF).</p>	<p>8</p>
<p>Module – IV Diversity & combining techniques: diversity mechanisms (space, time, frequency and polarization), diversity gain and array gain, combining techniques (SC, MRC, TC and EGC), concept of equalization.</p>	<p>7</p>
<p>Module – V Multiple access schemes: duplexing schemes, FDMA, TDMA, SDMA, spread spectrum technique and CDMA, OFDMA, ALOHA and CSMA.</p>	<p>7</p>

Text Book:

1. Vijay K. Garg, “Wireless Communications and Networks”, Morgan Kaufmann Publishers an Imprint of Elsevier, USA 2009 (Indian reprint).

Reference Books:

1. Simon Haykin and Michael Moher, “Modern Wireless Communications”, Parson Education, Delhi, 2005.
2. Theodore S Rappaport, “Wireless Communication: Principles and Practice” Prentice Hall of India, New Delhi, 2006, 2/e.
3. Sanjay Kumar, “Wireless Communication the Fundamental and Advanced Concepts” River Publishers, Denmark, 2015 (Indian reprint).

Gaps in the syllabus (to meet Industry/Profession requirements): Current technological developments in the field

POs met through Gaps in the Syllabus: PO1 & PO12

Topics beyond syllabus/Advanced topics/Design: Current research findings in the field of mobile cellular communication.

POs met through Topics beyond syllabus/Advanced topics/Design: PO1 & PO12

Course Outcome (CO) Attainment Assessment tools & Evaluation procedure**Direct Assessment**

Assessment Tool	% Contribution during CO Assessment
First Quiz	10
Mid Semester Examination	25
Second Quiz	10
Teacher’s Assessment	5
End Semester Examination	50

Indirect Assessment –

1. Student Feedback on Course Outcome.

Mapping of Course Outcomes onto Program Outcomes

Course Outcome	Program Outcomes (POs)												Program Specific Outcomes (PSOs)		
	1	2	3	4	5	6	7	8	9	10	11	12	1	2	3
CO1	3	2	2	1	1	1	1	1	2	2	1	2	3	2	2
CO2	3	3	2	3	2	1	1	1	2	2	1	1	3	2	2
CO3	3	3	2	3	2	1	1	1	2	2	1	1	1	2	3
CO4	3	3	2	3	3	1	1	1	2	2	1	1	3	2	1
CO5	3	3	2	3	3	1	1	1	2	2	1	1	3	2	1

Correlation Levels 1, 2 or 3 as defined below:

1: Slight (Low) 2: Moderate (Medium) 3: Substantial (High)

Mapping Between COs and Course Delivery (CD) methods

CD Code	Course Delivery Methods	Course Outcome	Course Delivery Method Used
CD1	Lecture by use of boards/LCD projectors/OHP projectors	CO1	CD1,CD2,CD6, CD8
CD2	Tutorials/Assignments	CO2	CD1, CD2, CD6, CD8
CD3	Seminars	CO3	CD1, CD2, CD6, CD8
CD4	Mini projects/Projects	CO4	CD1, CD2, CD6, CD8
CD5	Laboratory experiments/teaching aids	CO5	CD1,CD2,CD3, CD9
CD6	Industrial/guest lectures		
CD7	Industrial visits/in-plant training		
CD8	Self- learning such as use of NPTEL materials and internets		
CD9	Simulation		

COURSE INFORMATION SHEET

Industrial Electronics

Course Code: EC405 R1

Course title: **Industrial Electronics**

Pre-requisite(s): EC253 Analog Electronics Co- requisite(s):

Course type: Core

Credits: L: 3 T: 0 P: 0

Class schedule per week: 03

Class: B.E

Semester / Level: VII/IV

Branch: ECE Name

of Teacher:

Course Objectives

This course envisions to impart to students to:

1	Understand the concepts of power semiconductor devices and their triggering schemes.
2	Apply the concepts of control rectifiers for AC to DC power conversion.
3	Explain the commutation process in power semiconductor devices
4	Understand the operations of Inverter and Choppers
5	Design the DC and AC motor drives for speed control.

Course Outcomes

After the completion of this course, students will be able to:

CO1	Describe the functionality of power semiconductor devices and their triggering schemes.
CO2	Explain the concept of controlled rectifiers for AC to DC power conversion.
CO3	Explain the commutation process in power semiconductor devices
CO4	Demonstrate the operations of Inverter and Choppers
CO5	Design the DC and AC motor drives for speed control.

SYLLABUS

MODULE	(NO. OF LECTURE HOURS)
<p>Module – I Introduction Silicon Controlled Rectifier (SCR), SCR construction, Two transistor analogy, Characteristics, Gate characteristics, Different types of SCR. Construction and characteristics of DIAC and TRIAC.</p> <p>Triggering Schemes: dv/dt, Thermal, Light and Gate Triggering, Gate triggering using R and RC firing circuits, Firing circuit using UJT and 555 Timer, SCR protection.</p>	6
<p>Module – II Controlled Rectifiers: Analysis of single-phase Half Wave and Full Wave controlled rectifiers with resistive load and RL load, Flywheel diode, Circuit operation of Half controlled and fully controlled Bridge Rectifiers with Resistive and RL load. Three phase controlled Rectifiers; Circuit operation of three phase Half Wave and Full Wave controlled Rectifier circuits. DC and AC Voltage Regulators, SMPS.</p>	10
<p>Module – III Commutation: Natural and Forced Commutation, Self-Commutation, Impulse Commutation, Resonant Pulse Commutation, Complementary Commutation, Load Side Commutation, Line Side Commutation.</p>	8
<p>Module – IV Inverters: Principle and operation, Inverter classification, Voltage and Current driven Inverters, Single phase Inverters, Inverter circuits with Mc-Murray Commutation and Mc-Murray Bedford Commutation.</p> <p>Choppers: Basic Chopper Circuit, Types of Choppers, Step up and step-down choppers, Type A Chopper, Type B Chopper, Type C Chopper.</p>	10
<p>Module – V DC and AC Motor Control: DC Motor, One Quadrant and Two Quadrant Single Phase SCR Drive for DC Motor, AC Motor, Speed Control Methods for Induction Motor, Cycloconverters. Non-Motor Industrial Applications; Resistance Welding, Induction Heating, Dielectric Heating.</p>	6

Text Books:

1. Power Electronics by P.C. Sen., Tata McGraw Hill
2. Power Electronics Circuits, Devices and Application, by Muhammad H. Rashid

Reference Books:

Gaps in the syllabus (to meet Industry/Profession requirements): N/A

POs met through Gaps in the Syllabus:

Topics beyond syllabus/Advanced topics/Design:

POs met through Topics beyond syllabus/Advanced topics/Design:

Course Outcome (CO) Attainment Assessment Tools & Evaluation Procedure**Direct Assessment**

Assessment Tool	% Contribution during CO Assessment
First Quiz	10
Mid Semester Examination	25
Second Quiz	10
Teacher's Assessment	5
End Semester Examination	50

Indirect Assessment

1. Students' Feedback on Course Outcome.

Mapping of Course Outcomes onto Program Outcomes

Course Outcome	Program Outcomes (POs)												Program Specific Outcomes (PSOs)		
	1	2	3	4	5	6	7	8	9	10	11	12	13	14	15
CO1															
CO2															
CO3															
CO4															
CO5															

Correlation Levels 1, 2 or 3 as defined below:

1: Slight (Low) 2: Moderate (Medium) 3: Substantial (High)

Mapping Between COs and Course Delivery (CD) methods

CD Code	Course Delivery Methods	Course Outcome	Course Delivery Method Used
CD1	Lecture by use of Boards/LCD Projectors	CO1	CD1, and CD 8
CD2	Tutorials/Assignments	CO2	CD1, and CD 8
CD3	Seminars	CO3	CD1, and CD 8
CD4	Mini Projects/Projects	CO4	CD1, and CD 8
CD5	Laboratory Experiments/Teaching Aids	CO5	CD1, and CD 8
CD6	Industrial/Guest Lectures		
CD7	Industrial Visits/In-plant Training		
CD8	Self- learning such as use of NPTEL Materials and Internets		
CD9	Simulation		

COURSE INFORMATION SHEET
Computer Networking

Course Code: EC407 R1

Course Title: Computer Networking

Pre-requisite(s): Data Communication

Co- requisite(s):

Credits: L: 3 T: 1 P: 0

Class schedule per week: 03 Class:

B. Tech.

Semester / Level: Sixth

**Branch: Electronics & Communication Engineering Name
of Teacher:**

Course Objectives

This course envisions to impart to students to:

1	Understand the different network topologies, transmission media and different MAC sub-layers used in the design of a Local Area Network (LAN) and Wireless LAN's.
2.	Familiarize the layer of operation and working of different intermediate devices, network layer protocols and internet addressing mechanism.
3.	Familiarize with the transport layer protocols to be used as an end-to-end service provider.
4.	Illustrate different encryption and message authentication schemes to provide security at different layers.
5.	To outline the functioning of the Application layer and different protocols of application layers e.g. HTTP, SMTP, WWW, FTP, VOIP etc.

Course Outcomes

After the completion of this course, students will be able to:

CO1	Recall the basic reference model of LAN, their topologies and different types of intermediate systems in a network used.
CO2	Understand the basics of various internet protocols and their functioning.
CO3	Understand the basics of various internet and transport protocols and their functioning.
CO4	Explain the significance of network security in a public network like internet.
CO5	Analyze the different application layer protocols and their functioning.

SYLLABUS

MODULE	(NO. OF LECTURE HOURS)
<p>Module – I</p> <p>Local Area Network: Local Area Networks: Background, Topologies and Transmission Media, LAN standards IEEE 802 reference Model, Logical Link Control.</p> <p>Medium Access Control: Medium Access Control, IEEE 802.3 Medium Access Control, Ethernet, Fast Ethernet, Gigabit Ethernet, Token Ring and FDDI, IEEE 802.5 Transmission Medium Options.</p> <p>Connecting devices and Backbone Networks: Bridges, Functions of a Bridge, Bridge Protocol Architecture, Fixed routing, Spanning tree approach, Connecting devices like Repeaters, Hubs, Bridges ,Two-layer switches, Routers and Three layer switches, Backbone Networks, Bus Backbone, Star Backbone, Connecting remote LANs.</p>	11
<p>Module – II</p> <p>Internetworking Operations: Principles of Internetworking, Requirements, Architectural approaches, Connectionless Internetworking, Addressing, Routing techniques, Static versus Dynamic Routing,</p> <p>Internet Protocols: IPv4, Internet Control Message Protocol (ICMP), IPV6 Structure, Header, CIDR Addressing, ICMPV6.</p> <p>Internet work Operations: Unicast and Multicast routing, Autonomous Systems, Unicast routing protocol OSPF, Internet Group Management Protocol (IGMP), Border Gateway Protocol, Integrated Service Architecture, ISA Approach, Components, Services, Queuing Discipline, Resource Reservation Protocol (RSVP), Differentiated Services (DS).</p>	10
<p>Module – III</p> <p>Transport layer operations: Connection Oriented Transport Protocol Mechanisms, Reliable Sequencing networks services, Unreliable network services, TCP Services, TCP Header Format, TCP Mechanisms, TCP Implementation policy options, TCP Congestion Control, Retransmission Timer Management, Window Management, Quality of Service, User datagram Protocol (UDP).</p>	7
<p>Module – IV</p> <p>Network Security : Passive and Active Attacks, Symmetric Encryption, Encryption Algorithms, Key Distribution, Traffic Padding, Message Authentication, Hash function, Secure Hash function, Public-key Encryption, Digital Signature, RSA Public Key Encryption algorithm, Key Management,</p>	7

Secure Socket layer and Transport layer Security, SSL Architecture, SSL Record Protocol, Change Cipher Spec Protocol, Alert Protocol, Handshake Protocol, IP level security IPSEC, Application layer security PGP, Firewall, Virtual Private Networks.	
Module – V Application Layer Protocols: Distributed Applications: Electronic Mail, Simple Mail Transfer Protocol (SMTP), Multipurpose Internal Mail Extension (MIME), Client Server Model, Socket Interface, Simple Network Management Protocol (SNMP) SNMP V2 and SNMP V3, Hypertext Transfer Protocol (HTTP) Overview Message Entities, World Wide Web (WWW), HTML, Common Gateway Interface (CGI), Voice over IP (VOIP).	5

Text Books:

1. Data and Computer Communication, 7/e. by William Stallings.
2. Data Communication and Networking, 3/e. by Behrouz. A. Forouzan.

Reference Books:

1. The Internet and its protocols: A comparative approach. by Adrian Farrel.
2. Computer Networks 4/e by Andrew S. Tanenbaum.

Gaps in the Syllabus (to meet Industry/Profession requirements):

1. Simulation of different types of networks and their performance comparison.

POs met through Gaps in the Syllabus

3, 4 and 12

Topics beyond syllabus/Advanced topics/Design

1. Hardware implementation of MAC protocols.
2. Hardware implementation of Bridges and Routers.
3. Setting up of a practical internetwork.

POs met through Topics beyond syllabus/Advanced topics/Design

2, 3, 4, 12

Course Outcome (CO) Attainment Assessment Tools & Evaluation Procedure

Direct Assessment

Assessment Tool	% Contribution during CO Assessment
First Quiz	10

Mid Semester Examination	25
Second Quiz	10
Teacher's Assessment	5
End Semester Examination	50

Indirect Assessment

1. Students' Feedback on Course Outcome.

Mapping of Course Outcomes onto Program Outcomes

Course Outcome	Program Outcomes (POs)												Program Specific Outcomes (PSOs)		
	1	2	3	4	5	6	7	8	9	10	11	12	13	14	15
CO1	3	1	1	2	1	-	-	-	-	-	-	2	2	1	3
CO2	3	3	3	2	1	-	-	-	-	-	-	1	3	1	3
CO3	3	3	2	2	2	-	-	-	-	-	-	1	2	2	2
CO4	3	2	1	1	1	-	-	-	-	-	-	1	2	2	2
CO5	3	1	1	2	1	-	-	-	-	-	-	2	2	1	3

Correlation Levels 1, 2 or 3 as defined below:

1: Slight (Low) 2: Moderate (Medium) 3: Substantial (High)

Mapping between COs and Course Delivery (CD) methods

CD Code	Course Delivery Methods	Course Outcome	Course Delivery Method Used
CD1	Lecture by use of Boards/LCD Projectors	CO1	CD1
CD2	Tutorials/Assignments	CO2	CD1
CD3	Seminars	CO3	CD1 CD2
CD4	Mini Projects/Projects	CO4	CD1 and CD2
CD5	Laboratory Experiments/Teaching Aids	CO5	CD1 and CD2
CD6	Industrial/Guest Lectures		
CD7	Industrial Visits/In-plant Training		
CD8	Self- learning such as use of NPTEL Materials and Internets		
CD9	Simulation		

COURSE INFORMATION SHEET

Wireless Communication

Course Code: EC409 R1

Course Title: Wireless Communication

Pre-requisite(s): Knowledge of analog and digital communication

Co- requisite(s):

Credits: L: 3 T: 0 P: 0 C:3

Class schedule per week: 03 Class:

B. Tech.

Semester / Level: Six/Three

**Branch: Electronics & Communication Engineering Name
of Teacher:**

Course Objectives

This course envisions to impart to students to:

1.	An understanding on functioning of wireless communication system and evolution of different wireless communication systems and standards and various multiple access techniques.
2.	An understanding on cellular concept, cellular architecture and evolution of different generations and standards for mobile cellular communication.
3.	An ability to analyze different channel parameters, causes of impairments in signal propagation and impairment removal techniques.
4.	An ability to explain the architecture, functioning and protocols of various wireless communication networks.
5.	An ability to explain the capabilities and application of various wireless communication networks

Course Outcomes

After the completion of this course, students will be able to:

CO1	Demonstrate an understanding on functioning of wireless communication system and evolution of different wireless communication systems and standards and various multiple access techniques.
CO2	Demonstrate an understanding on cellular concept, cellular architecture and evolution of different generations and standards for mobile cellular communication.
CO3	Analyze different channel parameters, causes of impairments in signal propagation and impairment removal techniques.
CO4	Explain the architecture, functioning and protocols of various wireless communication networks.
CO5	Explain the capabilities and application of various wireless communication networks.

SYLLABUS

MODULE	(NO. OF LECTURE HOURS)
<p>Module – I</p> <p>Overview of wireless communication An overview of wireless communication, future vision, history of wireless communication, EM spectrum, basic elements in wireless communication systems, wireless communication system and standards: satellite communication system, GPS, paging system, cordless phone, wireless local loop, RFID.</p>	9
<p>Module – II</p> <p>Cellular communication and frequency reuse General architecture of a cellular system, hand-off in a cellular system, co-channel interference and adjacent channel interference, power control, evolution of mobile cellular communication (1G, 2G, 2.5G, 3G and beyond), typical cellular standards (AMPS, GSM, GPRS, WCDMA, LTE, concept of LTE-advanced).</p>	9
<p>Module – III</p> <p>Mobile cellular environment Multipath propagation and fading, free space propagation model, propagation path loss, outdoor and indoor propagation models, channel parameters (delay spread, doppler spread, coherence bandwidth, coherence time, LCR and ADF).</p>	8
<p>Module – IV</p> <p>Wireless communication networks Wireless personal area networks (Bluetooth, UWB and ZigBee), wireless local area networks (IEEE 802.11, network architecture, medium access methods, WLAN standards), wireless metropolitan area networks (WiMAX), Ad-hoc wireless networks.</p>	8
<p>Module – V</p> <p>Multiple access schemes Duplexing schemes, FDMA, TDMA, SDMA, spread spectrum technique and CDMA, OFDMA, ALOHA and CSMA.</p>	6

Text Books:

1. Vijay K Garg, “Wireless Communications and Networks”, Morgan Kaufmann Publishers an Imprint of Elsevier, USA 2009 (Indian reprint)

Reference Books:

1. Simon Haykin and Michael Moher, “Modern Wireless Communications”, Parson Education, Delhi, 2005
2. Sanjay Kumar, “Wireless Communication the Fundamental and Advanced Concepts” River Publishers, Denmark, 2015 (Indian reprint).

Gaps in the Syllabus (to meet Industry/Profession requirements) :Nil

POs met through Gaps in the Syllabus: NA

Topics beyond syllabus/Advanced topics/Design:

POs met through Topics beyond syllabus/Advanced topics/Design:

Course Outcome (CO) Attainment Assessment Tools & Evaluation Procedure:PO1

Direct Assessment

Assessment Tool	% Contribution during CO Assessment
First Quiz	10
Mid Semester Examination	25
Second Quiz	10
Teacher’s Assessment	5
End Semester Examination	50

Indirect Assessment

1. Students’ Feedback on Course Outcome.

Mapping of Course Outcomes onto Program Outcomes

Course Outcome	Program Outcomes (POs)												Program Specific Outcomes (PSOs)		
	1	2	3	4	5	6	7	8	9	10	11	12	13	14	15
CO1	3	2	1	1	-	-	-	-	-	-	-	2	3	2	1
CO2	3	2	1	1	1	-	-	-	-	-	-	2	3	2	2
CO3	3	2	2	2	2	-	-	-	-	-	-	2	3	2	1
CO4	3	3	3	4	2	-	-	-	-	-	-	2	3	2	3
CO5	3	3	3	4	2	-	-	-	-	-	-	2	3	2	2

Correlation Levels 1, 2 or 3 as defined below:

1: Slight (Low) 2: Moderate (Medium) 3: Substantial (High) **Mapping Between COs and Course Delivery (CD) methods**

CD Code	Course Delivery Methods	Course Outcome	Course Delivery Method Used
CD1	Lecture by use of Boards/LCD Projectors	CO1	CD1, CD8
CD2	Tutorials/Assignments	CO2	CD1, CD8
CD3	Seminars	CO3	CD1, CD8
CD4	Mini Projects/Projects	CO4	CD1, CD8
CD5	Laboratory Experiments/Teaching Aids	CO5	CD1, CD8
CD6	Industrial/Guest Lectures		
CD7	Industrial Visits/In-plant Training		
CD8	Self- learning such as use of NPTEL Materials and Internets		
CD9	Simulation		

COURSE INFORMATION SHEET

Speech and Audio Processing

Course Code: EC411 R1

Course Title: Speech and Audio Processing

Pre-requisite(s): Digital Signal Processing

Co- requisite(s): Probability and Random Processes

Credits: L: 3 T: 0 P: 0

Class schedule per week: 03 Class:

B. Tech.

Semester / Level: 04

**Branch: Electronics and Communication Engineering Name
of Teacher:**

Course Objectives

This course envisions to impart students to:

1	To understand speech production and human auditory model. To analyse structures of speech codecs and classification of speech coding techniques
2	To understand different speech signal processing techniques
3	To understand basics of scalar and vector quantization
4	To understand basic of LPC and its variants for various applications
5	To understand different coding techniques and speech coding standards

Course Outcomes

After the completion of this course, students will be able to:

CO1	Understand the basics of production and auditory models and apply speech codecs for speech coding techniques
CO2	Apply various signal processing techniques to speech signal for its enhancement
CO3	Analyse the quality and properties of speech signal
CO4	Modify and enhance the speech and audio signals using coding techniques
CO5	Design and evaluate the performance of an application based speech recognition system.

SYLLABUS

MODULE	(NO. OF LECTURE HOURS)
<p>Module – I Introduction- Speech production and modelling - Human Auditory System; General structure of speech coders; Classification of speech coding techniques – parametric, waveform and hybrid; Requirements of speech codecs –quality, coding delays, robustness.</p>	8
<p>Module – II Speech Signal Processing- Pitch-period estimation, all-pole and all-zero filters, convolution; Power spectral density, periodogram, autoregressive model, autocorrelation estimation.</p>	8
<p>Module – III Speech Quantization- Scalar quantization–uniform quantizer, optimum quantizer, logarithmic quantizer, adaptive quantizer, differential quantizers; Vector quantization – distortion measures, codebook design, codebook types.</p>	8
<p>Module – IV Linear Prediction of Speech- Basic concepts of linear prediction; Linear Prediction Analysis of non-stationary signals –prediction gain, examples; Levinson-Durbin algorithm; Long term and short-term linear prediction models; Moving average prediction, Scalar Quantization of LPC- Spectral distortion measures, Quantization based on reflection coefficient and log area ratio, bit allocation; Line spectral frequency – LPC to LSF conversions, quantization based on LSF, Linear Prediction Coding- LPC model of speech production; Structures of LPC encoders and decoders; Voicing detection; Limitations of the LPC model.</p>	8
<p>Module – V Code Excited Linear Prediction-CELP speech production model; Analysis-by-synthesis; Generic CELP encoders and decoders; Excitation codebook search – state-save method, zero-input zero-state method; CELP based on adaptive codebook, Adaptive Codebook search; Low Delay CELP and algebraic CELP, Speech Coding Standards-An overview of ITU-T G.726, G.728 and G.729 standards.</p>	8

Text Books:

1. L.R. Rabiner, B. H. Juang and B. Yegnanarayana, “Fundamentals of Speech Recognition”, Pearson, Education 2011
2. A. M. Kondo, “Digital Speech”, Second Edition (Wiley Students Edition), 2004.
3. W. C. Chu, “Speech Coding Algorithms: Foundation and Evolution of Standardized Coders”, Wiley Inter science, 2003.

Reference Books: NA**Gaps in the Syllabus (to meet Industry/Profession requirements)**

25. Applications of speech signal processing techniques through hardware platform.

POs met through Gaps in the Syllabus

NA

Topics beyond syllabus/Advanced topics/Design

Teaching through Research paper

POs met through Topics beyond syllabus/Advanced topics/Design

2

Course Outcome (CO) Attainment Assessment Tools & Evaluation Procedure**Direct Assessment**

Assessment Tool	% Contribution during CO Assessment
First Quiz	10
Mid Semester Examination	25
Second Quiz	10
Teacher’s Assessment	5
End Semester Examination	50

Indirect Assessment

1. Students’ Feedback on Course Outcome.

Mapping of Course Outcomes onto Program Outcomes

Course Outcome	Program Outcomes (POs)												Program Specific Outcomes (PSOs)		
	1	2	3	4	5	6	7	8	9	10	11	12	13	14	15
CO1	3	3	2	2	2	1	1			2	3	3	1	2	2
CO2	3	3	3	3	3	2	2			2	3	3	1	2	3
CO3	3	3	3	3	3	1	2		2	3	3	3	2	3	3
CO4	3	3	2	3	3	2	2	1	2	3	3	3	2	2	3
CO5	3	2	1	1	2	1	1		1	1	1	2	3	3	3

Correlation Levels 1, 2 or 3 as defined below:

1: Slight (Low) 2: Moderate (Medium) 3: Substantial (High)

Mapping Between COs and Course Delivery (CD) methods

CD Code	Course Delivery Methods	Course Outcome	Course Delivery Method Used
CD1	Lecture by use of Boards/LCD Projectors	CO1	CD1, CD2, CD 8
CD2	Tutorials/Assignments	CO2	CD1 and CD9
CD3	Seminars	CO3	CD1, CD2 and CD3
CD4	Mini Projects/Projects	CO4	CD1 and CD2
CD5	Laboratory Experiments/Teaching Aids	CO5	CD1, CD2, CD9
CD6	Industrial/Guest Lectures		
CD7	Industrial Visits/In-plant Training		
CD8	Self- learning such as use of NPTEL Materials and Internets		
CD9	Simulation		

COURSE INFORMATION SHEET

Microcontrollers and Interfacing

Course code: **EC413 R1**

Course title: **Microcontrollers and Interfacing**

Pre-requisite(s): Microprocessors Applications Co-requisite(s):

Credits: L: 3 T: 1 P:

Class schedule per week: 3x

Class: B. Tech

Semester / Level: VI/3

Branch: ECE Name

of Teacher:

Course Objectives

This course enables the students:

1.	Explain the concept of microcontrollers and embedded system architecture.
2.	Develop assembly language programming skill in the student for 8051 microcontroller.
3.	Explain the interrupt and serial I/O features of 8051 microcontroller
4.	To outline the importance of different peripheral devices & their interfacing to 8051.
5.	Introduce embedded microcontrollers and their programming

Course Outcomes

After the completion of this course, students will be able to:

CO1	Demonstrate the knowledge about microcontrollers and embedded systems architecture.
CO2	Write 8051 based assembly language program for given problem.
CO3	Will be able to interface 8051 with peripheral devices.
CO4	Will be able to communicate 8051 with peripheral devices using serial and parallel I/O and design and implement microcontroller based system for given application
CO5	Schematize the microcontroller based real time systems.

SYLLABUS

MODULE	(NO. OF LECTURE HOURS)
<p>Module – I Introduction to Microcontrollers, Microprocessors vs Microcontrollers, History and Applications of Microcontrollers, 8051 Architecture, Introduction, Features, Pin details, Internal Memory organization, General purpose RAM, Bit addressable RAM, Register banks, Special function Registers.</p>	10
<p>Module – II 8051 Addressing Modes, Boolean Processor, External Memory Addressing, Interrupt Structure and priorities, 8051 Instruction types like Data movement, Logic, Arithmetic, Control transfer and Program Control Instructions, Instruction Set in detail. 8051 Programming examples like Arithmetic and Logic operation, Branching, Looping, Stack Operations, Subroutines, Parameter passing, A few Industrial examples, Software and Hardware Development tools, Environments, Assembly Language, Interpreters, Debugging hints.</p>	10
<p>Module – III 8051 Interrupts and Timers/counters: Basics of interrupts, 8051 interrupt structure, Timers and Counters, 8051 timers/counters, programming 8051 timers in assembly and C. 8051 Serial Communication, connections to RS-232, Serial communication Programming in assembly and C.</p>	7
<p>Module – IV Basics of I/O concepts, I/O Port Operation, Interfacing 8051 to LCD, Keyboard, I/O devices interfacing with 8051 using 8255A, parallel and serial ADC, DAC, Stepper motor interfacing and DC motor interfacing and programming.</p>	8
<p>Module – V Introduction to Embedded Microcontrollers, 68 HC11 and 68 HC12 Microcontrollers, Software and Hardware development, I/O Resources, CPU12 Programming model, Basic Assembly Programming techniques, Introduction to Real time I/O and Multitasking.</p>	5

Text books:

1. Mohamed Ali Mazidi, Janice Gillispie Mazidi, “The 8051 microcontroller and embedded systems”, Pearson education, 2004
2. “Programming and Customising the 8051 Microcontroller”, by Myke Predko

Reference books:

1. “Advanced Microprocessor and Microcontrollers”, by S.K. Venkata Ram.

Gaps in the syllabus (to meet Industry/Professional requirements)

POs met through Gaps in the Syllabus

Topics beyond syllabus/Advanced topics/Design

POs met through Topics beyond syllabus/Advanced topics/Design

Course Outcome (CO) Attainment Assessment Tools & Evaluation Procedure

Direct Assessment

Assessment Tool	% Contribution during CO Assessment
First Quiz	10
Mid Semester Examination	25
Second Quiz	10
Teacher’s Assessment	5
End Semester Examination	50

Indirect Assessment

1. Students’ Feedback on Course Outcome.

Mapping of Course Outcomes onto Program Outcomes

Course Outcome	Program Outcomes (POs)												Program Specific Outcomes (PSOs)		
	1	2	3	4	5	6	7	8	9	10	11	12	13	14	15
CO1	3	3	3	2	2	2	2		1	1		1	2	2	1
CO2	3	3	2	3	2	1	1		1	1		1	2	2	1
CO3	3	3	2	3	3	1	1		1	1		1	2	2	1
CO4	3	3	3	2	2	2	2		1	1		1	2	2	1
CO5	3	3	2	3	2	1	1		1	1		1	2	2	1

Correlation Levels 1, 2 or 3 as defined below:

- 1: Slight (Low) 2: Moderate (Medium) 3: Substantial (High)

Mapping Between COs and Course Delivery (CD) methods

CD Code	Course Delivery Methods	Course Outcome	Course Delivery Method Used
CD1	Lecture by use of Boards/LCD Projectors	CO1	CD1,CD5,CD 8
CD2	Tutorials/Assignments	CO2	CD1,CD5,CD 8
CD3	Seminars	CO3	CD1,CD5,CD 8
CD4	Mini Projects/Projects	CO4	CD1,CD5,CD 8
CD5	Laboratory Experiments/Teaching Aids	CO5	CD1,CD5,CD 8
CD6	Industrial/Guest Lectures		
CD7	Industrial Visits/In-plant Training		
CD8	Self- learning such as use of NPTEL Materials and Internets		
CD9	Simulation		

COURSE INFORMATION SHEET
Neural Networks and Fuzzy System

Course Code: EC415 R1

Course Title: Neural Networks and Fuzzy System

Pre-requisite(s): Probability and Random Processes

Co-requisite(s):

Credits: L: 3 T: 0 P: 0

Class schedule per week: 03 Class:

B. Tech.

Semester / Level: 07

**Branch: Electronics and Communication Engineering Name
of Teacher:**

Course Objectives

This course envisions to impart students to:

6.	Understand the Artificial neural network and different learning strategies.
7.	Develop and design various machine learning techniques such as MLP, RBFNN, FLANN, deep Learning
8.	Understand the concept of fuzzy logic and its scope.
9.	Develop and design fuzzy logic techniques for control, clustering and classification tasks.
10.	Develop and analyze real time applications using machine learning and fuzzy logic techniques.

Course Outcomes

After the completion of this course, students will be able to:

CO1	Design and analyze neural network structures and its learning algorithms.
CO2	Develop and apply the neural network techniques to solve the complex pattern recognition, classification, clustering and prediction problems.
CO3	Apply and analyze the advanced machine learning techniques such as FLANN, Deep Learning, CNN
CO4	Create and analyze fuzzy logic theory, techniques and systems.
CO5	Develop fuzzy logic techniques for control, prediction and clustering applications.

SYLLABUS

MODULE	(NO. OF LECTURE HOURS)
Module – I Fundamental concepts, Introduction to artificial neural networks (ANN), Learning strategies: supervised & unsupervised learning, error correction learning, Hebbian learning, competitive learning, Kohonen self-organizing networks, vector quantization learning, reinforcement learning.	8
Module – II Perceptron architecture: Single and multi neuron perceptron, Perceptron learning rule, ADALINE network, LMS algorithm, Linear separable problem, multilayer perceptron networks, back propagation algorithm, virtues and limitations of back propagation, methods of speeding: momentum, variable learning rate, LevenbergMarquardt Algorithm	8
Module – III Radial basis function networks, interpolation problems, covers theorem, regularization networks, functional expansion networks: functional link artificial neural network (FLANN), Cascaded FLANN, Convolutional neural network, Deep learning, applications to classification and prediction.	8
Module – IV Fuzzy set theory & rules: Introduction to fuzzy systems, membership function, fuzzy set theory: fuzzy union, intersection and complement, fuzzy relational operations, Fuzzy rules: Linguistics variables, fuzzy IF-Then rules, Fuzzy reasoning.	8
Module – V Fuzzy inference systems: Introduction, Mamdani fuzzy model, Sugeno fuzzy model, Tekamoto fuzzy model, Neuro-fuzzy systems, applications to fuzzy control, clustering and classification.	8

Text Books:

5. “Neural network Design”- M.T. Hagan, B. Demuth & M. Beale, Thomson Learning, 2002
6. “Neuro-Fuzzy and Soft Computing”- J.S.R. Jang, C. T. Sun and E. Mizutani, PHI, NewDelhi

Reference Books:

1. “Neural Networks: A comprehensive Foundation” – Simon Haykin, Pearson education Gaps in the syllabus (to meet Industry/Profession requirements): N/A

Gaps in the Syllabus (to meet Industry/Profession requirements)

NA

POs met through Gaps in the Syllabus

PO8 will cover through paper writing/ technical report writing/ assignments/mini projects

Topics beyond syllabus/Advanced topics/Design

Teaching through Research paper

POs met through Topics beyond syllabus/Advanced topics/Design**Course Outcome (CO) Attainment Assessment Tools & Evaluation Procedure****Direct Assessment**

Assessment Tool	% Contribution during CO Assessment
First Quiz	10
Mid Semester Examination	25
Second Quiz	10
Teacher's Assessment	5
End Semester Examination	50

Indirect Assessment

1. Students' Feedback on Course Outcome.

Mapping of Course Outcomes onto Program Outcomes

Course Outcome	Program Outcomes (POs)												Program Specific Outcomes (PSOs)		
	1	2	3	4	5	6	7	8	9	10	11	12	13	14	15
CO1	2	2	1	3	1				1	1	1	2	1	2	2
CO2	3	2	3	3	1	1	1		1	1	2	2	1	2	3
CO3	2	2	1	3	1				1	1	1	2	2	3	3
CO4	3	2	3	3	1	1	1		1	1	2	2	2	2	3
CO5	3	2	3	3	2				1	1	1	2	3	3	3

Correlation Levels 1, 2 or 3 as defined below:

1: Slight (Low) 2: Moderate (Medium) 3: Substantial (High)

Mapping Between COs and Course Delivery (CD) methods

CD Code	Course Delivery Methods	Course Outcome	Course Delivery Method Used
CD1	Lecture by use of Boards/LCD Projectors	CO1	CD1, CD2, CD 8
CD2	Tutorials/Assignments	CO2	CD1 and CD9
CD3	Seminars	CO3	CD1, CD2 and CD3
CD4	Mini Projects/Projects	CO4	CD1 and CD2
CD5	Laboratory Experiments/Teaching Aids	CO5	CD1, CD2, CD9
CD6	Industrial/Guest Lectures		
CD7	Industrial Visits/In-plant Training		
CD8	Self- learning such as use of NPTEL Materials and Internets		
CD9	Simulation		

COURSE INFORMATION SHEET
Satellite Communication

Course Code: EC417 R1

Course Title: Satellite Communication

Pre-requisite(s):) Knowledge of Communication process, basic understanding of interference and noise in communication process, basic understanding of communication media.

Co-requisite(s):

Credits: L: 3 T: 0 P: 0 C:3

Class schedule per week: 03 Class:

B. Tech.

Semester / Level: Sixth/Third

Branch: Electronics & Communication Engineering Name of Teacher:

Course Objectives

This course envisions to impart to students to:

1.	An understanding on Satellite communication system
2.	An ability to evaluate the impact of interference on the satellite communication and complete link design.
3.	An ability to analyze different system parameters, causes of impairments in satellite communication system
4.	An understanding of Multiple access techniques to support satellite communication and special satellite systems
5.	An understanding on Satellite system, satellite sub system and earth station.

Course Outcomes

After the completion of this course, students will be able to:

CO1	Demonstrate an understanding on orbital and functional principles of satellite Communication
CO2	Architect, Interpret and select appropriate technologies for implementation of specified satellite communication systems.
CO3	Analyze and evaluate a satellite link and suggest enhancements to improve the link performance
CO4	Demonstrate an understanding of advancement and multiple access techniques to support satellite communication. And various satellite systems
CO5	Demonstrate an understanding on Satellite system, Satellite sub system and Earth station system.

SYLLABUS

MODULE	(NO. OF LECTURE HOURS)
<p>Module – I An overview of satellite communication: Satellite orbits, kepler’s law, Orbital Elements, Look Angles, Orbital perturbation, Coverage angle, slant range, Eclipse effect, Sun transit outage, Placement of a satellite in a geostationary orbit, Multistage rocket launchers and their Performance (trichy), Station keeping and Stabilization</p>	<p>10</p>
<p>Module – II Basic transmission theory: Friss transmission equation, EIRP, Completion Link design, System noise temperature G/T ratio, Noise figure and Noise temperature.</p>	<p>7</p>
<p>Module – III Communication Satellite Sub-systems: Space Platform (Bus) and Communication Subsystem (Payload), Satellite Antennas, Frequency reuse Antennas, Earth station antennas, Tracking, Equipment for earth stations, Equipment Reliability and Space qualification</p>	<p>7</p>
<p>Module – IV Multiple Access Techniques: Analog Satellite Communication Vs Digital Satellite Communication, Multiple Access Techniques, FDMA Concept, MCPC & SCPC, TDMA frame efficiency and super frame structure, Frame Acquisition and Synchronisation, CDMA concept, PN system, Spread spectrum, DSSS, DS CDMA, FHSS, FH CDMA. Demand Assignment Multiple Access, Digital Speech Interpolation and SPADE.</p>	<p>10</p>
<p>Module – V Special Purpose Satellite: INTELSAT, INMARSAT, Direct Broadcast Satellite, Very Small Aperture Terminal Networks, Mobile Satellite Networks and Global Positioning Satellite system</p>	<p>6</p>

Text Books:

1. T. Pratt & C. W. Bostian, Satellite Communication.
2. Tri T. Ha, Digital Satellite communication, McGraw Hill.

Reference Books:

1. Dennis Roddy, Satellite Communication, McGraw Hill

Gaps in the Syllabus (to meet Industry/Profession requirements)

POs met through Gaps in the Syllabus:

Topics beyond syllabus/Advanced topics/Design :

POs met through Topics beyond syllabus/Advanced topics/Design:

Course Outcome (CO) Attainment Assessment Tools & Evaluation Procedure:PO1

Direct Assessment

Assessment Tool	% Contribution during CO Assessment
First Quiz	10
Mid Semester Examination	25
Second Quiz	10
Teacher's Assessment	5
End Semester Examination	50

Indirect Assessment

1. Students' Feedback on Course Outcome.

Mapping of Course Outcomes onto Program Outcomes

Course Outcome	Program Outcomes (POs)												Program Specific Outcomes (PSOs)		
	1	2	3	4	5	6	7	8	9	10	11	12	13	14	15
CO1	3	1	1	2	1	-	-	-	-	-	-	2	3	2	1
CO2	3	3	3	2	1	-	-	-	-	-	-	1	3	2	2
CO3	3	3	2	2	2	-	-	-	-	-	-	1	3	2	1
CO4	3	2	1	1	1	-	-	-	-	-	-	1	3	2	3
CO5	3	1	1	2	1	-	-	-	-	-	-	2	3	2	2

Correlation Levels 1, 2 or 3 as defined below:

- 1: Slight (Low) 2: Moderate (Medium) 3: Substantial (High)

Mapping Between COs and Course Delivery (CD) methods

CD Code	Course Delivery Methods	Course Outcome	Course Delivery Method Used
CD1	Lecture by use of Boards/LCD Projectors	CO1	CD1, CD8
CD2	Tutorials/Assignments	CO2	CD1 ,CD8
CD3	Seminars	CO3	CD1, CD8
CD4	Mini Projects/Projects	CO4	CD1, CD8
CD5	Laboratory Experiments/Teaching Aids	CO5	CD1,CD8
CD6	Industrial/Guest Lectures		
CD7	Industrial Visits/In-plant Training		
CD8	Self- learning such as use of NPTEL Materials and Internets		
CD9	Simulation		

COURSE INFORMATION SHEET
Radar Engineering

Course Code: EC419 R1

Course Title: Radar Engineering

Pre-requisite(s): Knowledge of Electromagnetic fields and waves.

Co- requisite(s):

Credits: L: 3 T: 0 P: 0 C:3

Class schedule per week: 03 Class:

B. Tech.

Semester / Level: Seventh/Four

**Branch: Electronics & Communication Engineering Name
of Teacher:**

Course Objectives

This course envisions to impart to students to:

1.	An understanding on Radar Engineering and its applications
2.	An understanding of MTI and pulse Doppler Radar
3.	An ability to analyze different RADAR clutters
4.	An understanding of object Tracking by RADAR
5.	An understanding on working of RADAR Receiver and various Antennas used for RADAR.

Course Outcomes

After the completion of this course, students will be able to:

CO1	Demonstrate an understanding on RADAR and its functional principles
CO2	Demonstrate an understanding on MTI and pulse Doppler Radar
CO3	Analyze and evaluate performance in the presence of different RADAR clutters
CO4	Demonstrate an understanding of object tracking by RADAR
CO5	Demonstrate an understanding on RADAR Receiver and various Antennas used for RADAR.

SYLLABUS

MODULE	(NO. OF LECTURE HOURS)
Module – I INTRODUCTION TO RADAR Introduction, Basic Radar, Simple form of Radar equation, Radar Block diagram, Radar frequencies, Applications of Radar, Origin of Radar. Radar Range Equation, Detection of signals in noise, Receiver noise and signal to noise ratio, Integration of Radar pulses, Radar Cross Section of Targets, Pulse repetition frequency.	10
Module – II MTI AND PULSE DOPPLER RADAR Introduction to Doppler and MTI Radar, Delay line Cancellers, Digital MTI processing, Moving target Detector, Pulse Doppler Radar, Non Coherent MTI.	7
Module – III TRACKING RADAR Tracking with Radar, Mono-pulse tracking, Conical Scan and sequential lobbing, tracking in Range.	7
Module – IV RADAR CLUTTER Introduction to Radar Clutter, Surface Clutter radar equation, Land Clutter, Sea Clutter.	10
Module – V RADAR RECEIVER Functions of Radar Antennas, Antenna parameters, Antenna radiation pattern and Aperture illumination, Reflector antennas, Electronically steered phase array Antennas. The Radar receiver, Receiver Noise Figure, Super heterodyne receiver, Duplexers and Receiver protectors, Radar Displays	6

Text Books:

1. Introduction to Radar Systems”, M I Skolnik, 3/e, Tata McGraw Hill, New Delhi, 2001

Gaps in the Syllabus (to meet Industry/Profession requirements)

POs met through Gaps in the Syllabus:

Topics beyond syllabus/Advanced topics/Design :

POs met through Topics beyond syllabus/Advanced topics/Design:

Course Outcome (CO) Attainment Assessment Tools & Evaluation Procedure:PO1

Direct Assessment

Assessment Tool	% Contribution during CO Assessment
First Quiz	10
Mid Semester Examination	25
Second Quiz	10
Teacher's Assessment	5
End Semester Examination	50

Indirect Assessment

1. Students' Feedback on Course Outcome.

Mapping of Course Outcomes onto Program Outcomes

Course Outcome	Program Outcomes (POs)												Program Specific Outcomes (PSOs)		
	1	2	3	4	5	6	7	8	9	10	11	12	13	14	15
CO1	3	1	1	2	1	-	-	-	-	-	-	2	3	2	1
CO2	3	3	3	2	1	-	-	-	-	-	-	1	3	2	2
CO3	3	3	2	2	2	-	-	-	-	-	-	1	3	2	1
CO4	3	2	1	1	1	-	-	-	-	-	-	1	3	2	3
CO5	3	1	1	2	1	-	-	-	-	-	-	2	3	2	2

Correlation Levels 1, 2 or 3 as defined below:

- 1: Slight (Low) 2: Moderate (Medium) 3: Substantial (High)

Mapping Between COs and Course Delivery (CD) methods

CD Code	Course Delivery Methods	Course Outcome	Course Delivery Method Used
CD1	Lecture by use of Boards/LCD Projectors	CO1	CD1, CD8
CD2	Tutorials/Assignments	CO2	CD1 ,CD8
CD3	Seminars	CO3	CD1, CD8
CD4	Mini Projects/Projects	CO4	CD1, CD8
CD5	Laboratory Experiments/Teaching Aids	CO5	CD1,CD8
CD6	Industrial/Guest Lectures		
CD7	Industrial Visits/In-plant Training		
CD8	Self- learning such as use of NPTEL Materials and Internets		
CD9	Simulation		

COURSE INFORMATION SHEET
Real Time Embedded System

Course Code: EC421 R1

Course Title: Real Time Embedded System

Pre-requisite(s): Fundamental knowledge of VLSI Design, Digital Electronics, Signal Processing, Communication Systems Co-requisite(s):

Credits: L: 3 T: 0 P: 0

Class schedule per week: 03 Class:

B. Tech.

Semester / Level: VII

Branch: Electronics & Communication Engineering Name

of Teacher:

Course Objectives

This course envisions imparting to students to:

1.	Define the fundamental of embedded systems
2.	Show the correlation between hardware & software in embedded system
3.	Develop the suitable software for embedded system as per demand of present market.
4.	Design the highly secure optimized embedded systems
5.	Develop the tool and techniques for the development of real time system

Course Outcomes

After the completion of this course, students will be able to:

CO1	Recognize the interfacing and integration of component in SoC.
CO2	Design the highly secure ATM.
CO3	Develop the programmable kit to check the entire components in a board.
CO4	Develop the embedded systems & corresponding software as per demand of current market.
CO5	Demonstrate the tool and techniques for the development of real time system

SYLLABUS

MODULE	(NO. OF LECTURE HOURS)
Module – I Custom Input/Output Interfacing with VHDL and FPGA kit: Optical Display Interfacing, Buzzer Control, Liquid Crystal Display Interfacing, General-Purpose Switch Interfacing, Optical Sensor Interfacing,	9
Module – II Interfacing Digital Logic to the Real World with VHDL and FPGA kit: Basics of Signal Conditioning for Sensor Interfacing, Principles of Sensor Interfacing and Measurement Techniques, Multichannel Data Logging.	7
Module – III Real-World Control Device Interfacing with VHDL and FPGA kit: Relay, Solenoid Valve, Opto-Isolator, and Direct Current Motor Interfacing and Control, Servo and BLDC Motor Interfacing and Control, Stepper Motor Control.	8
Module – IV Introduction to IoT: What is the Internet of Things (IoT)? Potential IoT Applications, IoT Enabling Technologies: Sensors and Actuators, RFID and NFC (NearField Communication), LiFi, ZigBee.	8
Module – V Application of IoT: Digital Inputs and Outputs, Analog Inputs and Outputs, Accelerometer and Magnetometer, Digital Interfaces, Networking and Communications.	8

Textbooks:

1. A. Arockia Bazil Raj, “FPGA based embedded system developer's guide”, Taylor & Francis, CRC Press, 2018.
2. Perry Xiao, “Designing Embedded Systems and the Internet of Things (IoT) with the ARM Mbed”, John Wiley & Sons Ltd., 2018.

Reference Books:

1. Ronald Sass, Andrew G. Schmidt, “Embedded Systems Design with Platform FPGAs - Principles and Practices, Morgan Kaufmann Publishers, 2010.
2. Peter Marwedel, “Embedded System Design: Embedded System, Foundations of CyberPhysical Systems, and the internet of Things”, 3rd edition, Springer International, 2018.

Gaps in the syllabus (to meet Industry/Profession requirements): N/A

POs met through Gaps in the Syllabus: PO8 will be met through report writing/presentation based assignment

Topics beyond syllabus/Advanced topics/Design: Teaching through latest research paper

POs met through Topics beyond syllabus/Advanced topics/Design: Teaching through paper

Course Outcome (CO) Attainment Assessment Tools & Evaluation Procedure

Direct Assessment

Assessment Tool	% Contribution during CO Assessment
First Quiz	10
Mid Semester Examination	25
Second Quiz	10
Teacher's Assessment	5
End Semester Examination	50

Indirect Assessment

1. Students' Feedback on Course Outcome.

Mapping of Course Outcomes onto Program Outcomes

Course Outcome	Program Outcomes (POs)												Program Specific Outcomes (PSOs)		
	1	2	3	4	5	6	7	8	9	10	11	12	13	14	15
CO1	3	3	3	3	3	2	3	3	3	2	3	2	2	2	3
CO2	3	3	3	3	3	2	3	3	3	3	3	2	2	2	3
CO3	3	3	3	3	3	2	2	3	2	2	2	2	3	3	3
CO4	3	3	3	2	3	3	2	3	2	3	2	2	3	3	3
CO5	3	3	3	3	3	3	2	3	2	2	3	2	3	3	3

Correlation Levels 1, 2 or 3 as defined below:

1: Slight (Low) 2: Moderate (Medium) 3: Substantial (High)

Mapping Between COs and Course Delivery (CD) methods

CD Code	Course Delivery Methods	Course Outcome	Course Delivery Method Used
CD1	Lecture by use of Boards/LCD Projectors	CO1	CD1, CD7, CD8
CD2	Tutorials/Assignments	CO2	CD1 and CD9
CD3	Seminars	CO3	CD1, CD2 ,CD3
CD4	Mini Projects/Projects	CO4	CD1 and CD2
CD5	Laboratory Experiments/Teaching Aids	CO5	CD1 and CD2
CD6	Industrial/Guest Lectures		
CD7	Industrial Visits/In-plant Training		
CD8	Self- learning such as use of NPTEL Materials and Internets		
CD9	Simulation		

COURSE INFORMATION SHEET
Bio-Medical Electronics & Signal Processing

Course Code: EC423 R1

Course Title: Bio-Medical Electronics & Signal Processing

Pre-requisite(s): Signal Processing Techniques, Time Frequency and Wavelet Transform, Probability and Random Processes, Multichannel Signal Processing **Co- requisite(s):**

Credits: L: 3 T: 0 P: 0

Class schedule per week: 03 Class:

B. Tech.

Semester / Level: VII

Branch: Electronics and Communication Engineering Name

of Teacher:

Course Objectives

This course envisions to impart to students to:

1.	Understand the fundamentals of Digital Signal Processing and Biomedical Signal Processing.
2.	Grasp the concept of stochastic processes to develop advanced Biomedical signal processing concept.
3.	Comprehend Digital Signal Processing and Biomedical Signal Processing.
4.	Grasp how to integrate the concept of matrix algebra, probability models, random processes and linear algebra to Separate information Source using Spatial filters.
5.	To develop and ability to evaluate the performance of BSS algorithm in diverse areas of application with the help of practical examples.

Course Outcomes

After the completion of this course, students will be able to:

CO1	Distinguish Digital Signal Processing and Biomedical Signal Processing.
CO2	Use the concept of stochastic processes to develop advanced Biomedical signal processing concept.
CO3	Analyse Biomedical signals using PCA, BSS and ICA to separate or decorrelate the Multichannel Biomedical Signal.
CO4	Integrate the concept of matrix algebra, probability models, random processes and linear algebra to develop Spatial filters for pattern classification.
CO5	Apply the BSS algorithm as preprocessing method before feature extraction over real time signals

SYLLABUS

MODULE	(NO. OF LECTURE HOURS)
<p>Module – I Acquisition, Generation of Bio-signals, Origin of bio-signals, Types of biosignals, Study of diagnostically significant bio-signal parameters, Electrodes for bio-physiological sensing and conditioning, Electrode-electrolyte interface, polarization, electrode skin interface and motion artefact, biomaterial used for electrode, Types of electrodes (body surface, internal, array of electrodes, microelectrodes), Practical aspects of using electrodes, Acquisition of bio-signals (signal conditioning) and Signal conversion (ADC's DAC's) Processing, Digital filtering</p>	12
<p>Module – II Biomedical signal processing by Fourier analysis, Bio-Medical signal processing by wavelet (time frequency) analysis, Analysis (Computation of signal parameters that are diagnostically significant)</p>	9
<p>Module – III Classification of signals and noise, Spectral analysis of deterministic, stationary random signals and non-stationary signals, Coherent treatment of various biomedical signal processing methods and applications.</p>	8
<p>Module – IV Principal component analysis, Correlation and regression, Analysis of chaotic signals Application areas of Bio–Signals analysis Multiresolution analysis (MRA) and wavelets, Principal component analysis (PCA), Independent component analysis (ICA)</p>	6
<p>Module – V Pattern classification–supervised and unsupervised classification, Neural networks, Support vector Machines, Hidden Markov models. Examples of biomedical signal classification examples</p>	6

References:

1. W. J. Tompkins, “Biomedical Digital Signal Processing”, Prentice Hall, 1993.
2. Eugene N Bruce, “Biomedical Signal Processing and Signal Modeling”, John Wiley & Son’s _publication, 2001.

Reference Book:

1. Myer Kutz, “Biomedical Engineering and Design Handbook, Volume I”, McGraw Hill, 2009._
2. D C Reddy, “Biomedical Signal Processing”, McGraw Hill, 2005.
3. Katarzyn J. Blinowska, Jaroslaw Zygierewicz, “Practical Biomedical Signal Analysis Using MATLAB”, 1st Edition, CRC Press, 2011.

Gaps in the Syllabus (to meet Industry/Profession requirements)

Multi-Channel Signal Processing is an advance course; hence it only lays down the foundation of multichannel biomedical signal processing, pattern recognition and classification problem.

POs met through Gaps in the Syllabus

May be met through laboratory simulations, experiments, and design problems.

Topics beyond syllabus/Advanced topics/Design

7. Application of Multi-Channel Signal Processing helps to analyze the multi-channel biomedical signal.
8. Extraction of Pattern vector from independent components for the development of decision support system for various applications.

POs met through Topics beyond syllabus/Advanced topics/Design

Assignments & Seminars

Course Outcome (CO) Attainment Assessment Tools & Evaluation Procedure**Direct Assessment**

Assessment Tool	% Contribution during CO Assessment
First Quiz	10
Mid Semester Examination	25
Second Quiz	10
Teacher’s Assessment	5
End Semester Examination	50

Indirect Assessment

1. Students’ Feedback on Course Outcome.

Mapping of Course Outcomes onto Program Outcomes

Course Outcome	Program Outcomes (POs)												Program Specific Outcomes (PSOs)		
	1	2	3	4	5	6	7	8	9	10	11	12	13	14	15
CO1	2	2	3	3	2	3	1	2	3	3	3	3	3	3	2
CO2	2	2	3	3	2	3	1	2	3	3	3	3	3	3	2
CO3	2	2	3	3	2	3	1	3	3	3	3	3	3	3	2
CO4	2	2	3	3	2	3	1	2	3	3	3	3	3	3	2
CO5	1	1	1	1	1	1	1	1	1	1		1	1	1	1

Correlation Levels 1, 2 or 3 as defined below:

1: Slight (Low) 2: Moderate (Medium) 3: Substantial (High)

Mapping between COs and Course Delivery (CD) methods

CD Code	Course Delivery Methods	Course Outcome	Course Delivery Method Used
CD1	Lecture by use of Boards/LCD Projectors	CO1	CD1, CD2, CD5, CD8
CD2	Tutorials/Assignments	CO2	CD1, CD2, CD5, CD8
CD3	Seminars	CO3	CD1, CD2, CD3, CD4, CD5, CD8, CD9.
CD4	Mini Projects/Projects	CO4	CD1, CD2, CD3, CD4, CD5, CD8, CD9.
CD5	Laboratory Experiments/Teaching Aids	CO5	CD4, CD5, CD7, CD9
CD6	Industrial/Guest Lectures		
CD7	Industrial Visits/In-plant Training		
CD8	Self- learning such as use of NPTEL Materials and Internets		
CD9	Simulation		

COURSE INFORMATION SHEET
Low Power VLSI Circuits

Course code: EC425 R1

Course title: Low Power VLSI Circuits

Pre-requisite(s): EC101 Basics of Electronics & Communication Engineering, EC201

Electronic Devices Co- requisite(s):

Credits: L: 3 T: 0 P: 0 C: 3

Class schedule per week: 03 **Class:** B.

Tech.

Semester / Level: VII/04

Branch: ECE

Name of Teacher:

Course Objectives

This course enables the students to:

A.	Understand nanometre transistor models, power and energy basics.
B.	Interpret the power optimization techniques during design time at circuit, architecture and system level and apply the perceived knowledge.
C.	Appraise and analyse the power optimization techniques @ design time for memory, interconnect and clock.
D.	Appraise and evaluate power optimization techniques @ Standby for memory, circuits and systems.
E.	Create/design low-power/low-voltage analog circuits in weak inversion.

Course Outcomes

After the completion of this course, students will be able to:

CO1	Describe and illustrate the nanometre transistor models, power and energy basics.
CO2	Make use of power optimization techniques @ design time at circuit, architecture and system level; sketch and explain with examples.
CO3	Experiment with power optimization techniques @ design time for memory, interconnect and clock. Illustrate the benefits of those techniques with design examples and analyse them.
CO4	Apply power optimization techniques @ standby for memory, circuits and systems; Schematize design examples, assess power optimization techniques and summarize their benefits.
CO5	Design and schematize low-power/low-voltage analog circuits in weak inversion region.

Syllabus

MODULE	(NO. OF LECTURE HOURS)
<p>Module – I Nanometer Transistor Models, Power and Energy Basics: Nanometer transistor behavior and models, velocity saturation model, alpha power model, leakage currents in a nanometer MOSFET, variability, sources of variability, device and technology innovations; Digital design metrics – power, delay and energy metrics, power-delay and energy– delay trade-offs, dynamic power, short-circuit power, static power, sources of static power dissipation, optimizing power at design time.</p>	8
<p>Module – II Optimizing Power @ Design Time: Circuit Level Techniques, Architecture, Algorithms, and Systems: Optimization framework for energy–delay trade-off, dynamic-power optimization, multiple supply voltages, transistor sizing, technology mapping, static-power optimization, multiple thresholds, Transistor stacking; The architecture/system trade-off space, concurrency improves energy-efficiency, exploring alternative topologies, removing inefficiency, and the cost of flexibility.</p>	8
<p>Module – III Optimizing Power @ Design Time: Memory, Interconnect and Clocks: Role of memory in ICs, Cache Memory Architectures, SRAM Metrics, Power breakdowns of SRAM, Power-saving techniques for SRAM, Non-traditional cells, 6T SRAM Cell with Feedback; Interconnect basics, ITRS projection on interconnect and clock, Increasing Impact of Interconnect, Novel interconnect media, Lower Bounds on Interconnect Energy, Reducing Interconnect Power/Energy, Wire Energy–Delay Trade-off.</p>	8
<p>Module – IV Optimizing Power @ Standby: Memory, Circuits and Systems: Standard SRAM cells and SRAM metrics, optimizing power @ standby, data retention voltage (DRV) and transistor sizes, RBB and VSS raising. Sleep Mode Management, Trade-Off between Sleep Modes and Sleep Time, Dynamic power in standby – Clock gating to reduce power, Sleep Transistor sizing and Placement, Power gating, Dynamic Body Biasing, Supply voltage ramping, Boosted-Gate MOS (BGMOS), Boosted-Sleep MOS, Virtual Supplies.</p>	8
<p>Module – V Design of Low-Power/Low-Voltage Analog Circuits in Weak Inversion Minimum Saturation Voltage, Cascode mirror in weak or moderate inversion, low-voltage amplifiers: CMOS inverter-amplifier, Maximum Transconductance to-Current Ratio: Differential Pair, Linearized differential pair; Single-Stage Operational Transconductance Amplifiers (OTA): Voltage follower for a resistive load; Exponential Characteristics: Voltage and Current Reference, Minimum Energy Point Analysis.</p>	8

Textbooks:

6. Jan M. Rabaey, “Low power essentials”, First Edition, Springer, 2009, ISBN 978-0-38771712-8.
7. Alice Wang, Benton H. Calhoun, A. P. Chandrakasan “Sub-threshold Design for Ultra Low-Power Systems”, Springer, 2006, ISBN-13: 978-0387335155.

Reference Book:

1. Kaushik Roy, Sharat Prasad, “Low power CMOS VLSI circuit design”, John Wiley sons Inc., 2000.
2. Jan M. Rabaey, “Digital Integrated Circuits - A Design Perspective”, 2nd Edition, Prentice Hall, 2003.
3. P. Rashinkar, Paterson and L. Singh, “Low Power Design Methodologies”, Kluwer Academic, 2002.

Gaps in the syllabus (to meet Industry/Profession requirements):

1. Hands-on-practical for CMOS IC (Integrated Circuit) fabrication.

POs met through Gaps in the Syllabus:

10

Topics beyond syllabus/Advanced topics/Design:

1. RF circuits.

POs met through Topics beyond syllabus/Advanced topics/Design:

10

Course Outcome (CO) Attainment Assessment Tools and Evaluation Procedure**Direct Assessment**

Assessment Tool	% Contribution during CO Assessment
First Quiz	10
Mid Semester Examination	25
Second Quiz	10
Teacher’s Assessment	5
End Semester Examination	50

Indirect Assessment

1. Students’ Feedback on Course Outcome.

Mapping of Course Outcomes onto Program Outcomes

Course Outcome	Program Outcomes (POs)												Program Specific Outcomes (PSOs)		
	1	2	3	4	5	6	7	8	9	10	11	12	13	14	15
CO1	3	3	2	3	3	1	1			3		3	3	2	1
CO2	3	3	1	3	3	3	2			3		3	3	1	1
CO3	3	3	2	3	3	3	1			3		3	3	2	1
CO4	3	3	1	3	3	2	2			3		3	3	1	1
CO5	3	3	2	3	3	2	2			3		3	3	2	1

Correlation Levels 1, 2 or 3 as defined below:

1: Slight (Low) 2: Moderate (Medium) 3: Substantial (High)

Mapping Between COs and Course Delivery (CD) methods

CD Code	Course Delivery Methods	Course Outcome	Course Delivery Method Used
CD1	Lecture by use of Boards/LCD Projectors	CO1	CD1, CD7, CD 8
CD2	Tutorials/Assignments	CO2	CD1 and CD9
CD3	Seminars	CO3	CD1, CD2 and CD3
CD4	Mini Projects/Projects	CO4	CD1 and CD2
CD5	Laboratory Experiments/Teaching Aids	CO5	CD1 and CD2
CD6	Industrial/Guest Lectures		
CD7	Industrial Visits/In-plant Training		
CD8	Self- learning such as use of NPTEL Materials and Internets		
CD9	Simulation		

COURSE INFORMATION SHEET

ASIC Design

Course Code: EC427 R1

Course Title: ASIC Design

Pre-requisite(s): VLSI Systems, Digital System Design

Co- requisite(s):

Credits: L: 3 T: 0 P: 0

Class schedule per week: 03 Class:

B. Tech.

Semester / Level:

**Branch: Electronics & Communication Engineering Name
of Teacher:**

Course Objectives

This course envisions imparting to students to:

1.	Recognize the fundamental of Semicustom IC Design
2.	Show the importance of VHDL in Semicustom IC Design
3.	Analyze the Sequential processing in System Design
4.	Design the highly secure optimized systems
5.	Develop a processor using VHDL.

Course Outcomes

After the completion of this course, students will be able to:

CO1	Recognize the importance of Semicustom ICs Design.
CO2	Design the optimize architecture using VHDL.
CO3	Develop the sequential processing unit for customized system.
CO4	Develop the highly secure system for various applications.
CO5	Design a processor using VHDL.

SYLLABUS

MODULE	(NO. OF LECTURE HOURS)
Module – I Introduction to VHDL: System design with uses, History of VHDL, Simulation fundamentals, Modeling hardware, and Language basics, Building blocks in VHDL, Design units and library.	8
Module – II Sequential Processing: Process statement, Signal vs variable assignment, Sequential statements, For loop, While loop, Condition statements, Examples of half adder and full adder, Test bench.	8
Module – III Data Types and Subprograms: Data types, Scalar, Composite, Access type, File type; Arrays; Objects, Signal variables, Constants and files, Association lists, Interface lists, Structural description, Examples, Subprogram, Functions, Conversion function, Resolution functions, Procedures.	8
Module – IV Packages and VHDL Synthesis: Packages, Package declaration, deferred constants, Subprogram declaration. Simple gate - concurrent assignment, IF control flow statement, Case control flow statement, Simple sequential statements, Asynchronous reset, Asynchronous preset and clear, Complex sequential statements.	8
Module – V Combinational & Sequential Circuit Design using VHDL: Multiplexers, Decoders, Encoder, Code Converter, Flip-flops, Counters, Registers, Memory design, processor design.	8

Text Books:

1. “VHDL” by Douglas Perry, TMH, 1999.
2. **VHDL SYNTHESIS** by J. Bhasker, BS Publication 2004.

Reference Books:

1. Fundamental of Digital Logic with VHDL DESIGN, by Stephen Brown I Zvonko Vranesic, The McGraw-Hill Companies.

Gaps in the syllabus (to meet Industry/Profession requirements): N/A

POs met through Gaps in the Syllabus: PO8 will be met though report writing/presentation based assignment

Topics beyond syllabus/Advanced topics/Design: Teaching through paper

POs met through Topics beyond syllabus/Advanced topics/Design: Teaching through latest research paper

Course Outcome (CO) Attainment Assessment Tools & Evaluation Procedure

Direct Assessment

Assessment Tool	% Contribution during CO Assessment
First Quiz	10
Mid Semester Examination	25
Second Quiz	10
Teacher's Assessment	5
End Semester Examination	50

Indirect Assessment

1. Students' Feedback on Course Outcome.

Mapping of Course Outcomes onto Program Outcomes

Course Outcome	Program Outcomes (POs)												Program Specific Outcomes (PSOs)		
	1	2	3	4	5	6	7	8	9	10	11	12	13	14	15
CO1	3	3	3	3	3	2	3	3	3	2	3	2	2	3	2
CO2	3	3	3	3	3	2	3	3	3	3	3	2	2	3	2
CO3	3	3	3	3	3	2	2	2	2	2	2	2	2	3	1
CO4	3	3	3	2	3	3	2	3	2	3	2	2	2	3	1
CO5	3	3	3	3	3	3	2	2	2	2	3	2	2	3	1

Correlation Levels 1, 2 or 3 as defined below:

1: Slight (Low) 2: Moderate (Medium) 3: Substantial (High)

Mapping Between COs and Course Delivery (CD) methods

CD Code	Course Delivery Methods	Course Outcome	Course Delivery Method Used
CD1	Lecture by use of Boards/LCD Projectors	CO1	CD1, CD7, CD8
CD2	Tutorials/Assignments	CO2	CD1 and CD9
CD3	Seminars	CO3	CD1, CD2 and CD3
CD4	Mini Projects/Projects	CO4	CD1 and CD2
CD5	Laboratory Experiments/Teaching Aids	CO5	CD1 and CD2
CD6	Industrial/Guest Lectures		
CD7	Industrial Visits/In-plant Training		
CD8	Self- learning such as use of NPTEL Materials and Internets		
CD9	Simulation		

COURSE INFORMATION SHEET
Time Frequency and Wavelet Transform

Course Code: EC429 R1

Course Title: Time Frequency and Wavelet Transform

Pre-requisite(s): Signals and Systems, Signal Processing Techniques, Probability and Random Processes

Co- requisite(s):

Credits: L: 3 T: 0 P: 3

Class schedule per week: 03 Class:

B. Tech.

Semester / Level: VI

Branch: Electronics and Communication Engineering Name of Teacher:

Course Objectives

This course envisions to impart to students to:

1	Understand the mathematical basis of the wavelet transform and its performance in the analysis of non-stationary signals.
2	Understand the concepts and properties of Continuous Wavelet Transform, MultiResolution Analysis, Discrete Wavelet Transform and Wavelet Packets.
3	Learn to implement Discrete Wavelet transform using Filter banks and Fast Lifting Scheme.
4	Learn the time domain and frequency domain approaches for the construction of wavelets.
5	Implement Discrete Wavelet Transform and Wavelet Packet Transform for various applications like

Course Outcomes

After the completion of this course, students will be able to:

CO1	Demonstrate understanding on the wavelet transform and its performance in the analysis of non-stationary signals.
CO2	Describe the concept and properties of Continuous Wavelet Transform, Multi-Resolution Analysis, Discrete Wavelet Transform and Wavelet Packets.
CO3	Demonstrate understanding on Discrete Wavelet transform using Filter banks and Fast Lifting Scheme. And time domain and frequency domain approaches for the construction of wavelets.
CO4	Analyse the impact of Discrete Wavelet Transform and Wavelet Packet Transform for various applications like Signal compression, de-noising, detection of anomalies in ECG, EEG etc.
CO5	Apply the time frequency wavelet transform to extract the feature from real time signals

SYLLABUS

MODULE	(NO. OF LECTURE HOURS)
<p>Module – I Why wavelet transform? Stationary and Non-stationary Signal, Limitations of standard Fourier analysis, Introduction to time frequency analysis, Windowed Fourier transforms (STFT), Signal representation with continuous and discrete STFT, concept of time-frequency resolution, Resolution problem associated with STFT, Heisenberg's Uncertainty principle and time frequency tiling, Stock-well transform, Wigner-Ville transform, Cohen's Class distribution.</p>	8
<p>Module – II Continuous time wavelet transforms, Wavelet function and its properties, energy spectrum of wavelet, Nyquist Filters, Half band filters, Introduction, M-channel Filter banks, QMF banks, Perfect reconstruction systems, Alias free filter banks, Paraunitary perfect reconstruction Filter banks, Linear phase perfect reconstruction QMF banks.</p>	9
<p>Module – III Discrete wavelet transforms, Filter bank analysis of DWT, tiling of the timefrequency plane, dyadic grid sampling, Scaling function, Fast wavelet algorithm, compactly supported wavelets, Cascade algorithm, Franklin and spline wavelets.</p>	9
<p>Module – IV Wave Packet Analysis, Hilbert space frames. Frame representation. Representation of signals by frames. Iterative reconstruction. Frame algorithm. Construction of wavelets. Multiresolution analysis, Introduction to frames and biorthogonal wavelets.</p>	8
<p>Module – V Signal Analysis and synthesis, two-dimensional wavelet systems, Application of wavelet theory to signal denoising, image and video compression, multi-tone digital communication, transient detection.</p>	6

Text Books:

1. Y.T. Chan, Wavelet Basics, Kluwer Publishers, Boston, 1993.
2. I. Daubechies, Ten Lectures on Wavelets, Society for Industrial and Applied Mathematics, Philadelphia, PA, 1992.
3. C. K. Chui, An Introduction to Wavelets, Academic Press Inc., New York, 1992.
4. A.N. Akansu and R.A. Haddad, Multiresolution signal Decomposition: Transforms, Subbands and Wavelets, Academic Press, Oranld, Florida, 1992.

Reference Book:

1. Gerald Kaiser, A Friendly Guide to Wavelets, Birkhauser, New York, 1995.
2. P. P. Vaidyanathan, Multirate Systems and Filter Banks, Prentice Hall, New Jersey, 1993.
3. B.Boashash, Time-Frequency signal analysis, In S.Haykin, (editor), Advanced Spectral Analysis, pages 418--517. Prentice Hall, New Jersey, 1991.

Gaps in the Syllabus (to meet Industry/Profession requirements)

Time frequency and wavelet transform is an advance course; hence it only lays down the foundation of pattern recognition and classification problem.

POs met through Gaps in the Syllabus

May be met through laboratory simulations, experiments, and design problems.

Topics beyond syllabus/Advanced topics/Design

Application of **Time frequency and wavelet transform** in the analysis of time varying signal. Extraction of Pattern vector from time varying signal for the development of decision support system for various applications.

POs met through Topics beyond syllabus/Advanced topics/Design

Assignments & Seminars

Course Outcome (CO) Attainment Assessment Tools & Evaluation Procedure

Direct Assessment

Assessment Tool	% Contribution during CO Assessment
First Quiz	10
Mid Semester Examination	25
Second Quiz	10
Teacher's Assessment	5
End Semester Examination	50

Indirect Assessment

1. Students' Feedback on Course Outcome.

Mapping of Course Outcomes onto Program Outcomes

Course Outcome	Program Outcomes (POs)												Program Specific Outcomes (PSOs)		
	1	2	3	4	5	6	7	8	9	10	11	12	13	14	15
CO1	2	2	3	3	2	3	1	2	3	3	3	3			
CO2	2	2	3	3	2	3	1	2	3	3	3	3			
CO3	2	2	3	3	2	3	1	3	3	3	3	3			
CO4	2	2	3	3	2	3	1	2	3	3	3	3			
CO5	1	1	1	1	1	1	1	1	1	1		1			

Correlation Levels 1, 2 or 3 as defined below:

1: Slight (Low) 2: Moderate (Medium) 3: Substantial (High) **Mapping between COs and Course Delivery (CD) methods**

CD Code	Course Delivery Methods	Course Outcome	Course Delivery Method Used
CD1	Lecture by use of Boards/LCD Projectors	CO1	CD1, CD2, CD5, CD8
CD2	Tutorials/Assignments	CO2	CD1, CD2, CD5, CD8
CD3	Seminars	CO3	CD1, CD2, CD3, CD4, CD5, CD8, CD9.
CD4	Mini Projects/Projects	CO4	CD1, CD2, CD3, CD4, CD5, CD8, CD9.
CD5	Laboratory Experiments/Teaching Aids	CO5	CD4, CD5, CD7, CD9
CD6	Industrial/Guest Lectures		
CD7	Industrial Visits/In-plant Training		
CD8	Self- learning such as use of NPTEL Materials and Internets		
CD9	Simulation		

COURSE INFORMATION SHEET
Digital Image and Video Processing

Course Code: EC431 R1

Course Title: Digital Image and Video Processing

Pre-requisite(s): Digital Signal processing.

Co-requisite(s):

Credits: L: 3 T: 0 P: 0

Class schedule per week: 03 Class:

B. Tech.

Semester / Level: VII/04

**Branch: Electronics and Communication Engineering Name
of Teacher:**

Course Objectives

This course envisions to impart students to:

1.	To gain understanding on digital image formation, characteristics and its processing steps.
2.	To demonstrate the use of different spatial and frequency domain processing techniques to improve the image quality.
3.	To apply various segmentation and compression techniques of an image.
4.	To introduce various image description and representation methods for computer vision applications.
5.	To understand the basic video processing and coding methods.

Course Outcomes

After the completion of this course, students will be able to:

CO1	Develop an understanding on the image formation, pixel characteristics and video processing step.
CO2	Have an ability to analyze the image quality using transformed and spatial domain filters.
CO3	Have an ability to segment and represent the image for computer vision tasks. Have an ability to analyze the different image and video compression techniques and to evaluate its performance.
CO4	Develop an ability to apply video segmentation, motion detection and coding procedures.
CO5	Design the basic building blocks of image/video compression techniques

SYLLABUS

MODULE	(NO. OF LECTURE HOURS)
<p>Module – I Fundamental steps in Digital Image Processing, Components of an Image processing system, Digital Image Representation, Basic relationship between pixels, Basic Arithmetic/Logic operations on image: Image subtraction, Image averaging, Color image processing fundamentals: Color Modules, RGB, HIS, Lab color modules, Convolution and Correlation theorem.</p>	8
<p>Module – II Gray Level Transformations, Histogram Processing, Smoothing and Sharpening with Spatial Domain Filters, Fourier Transform, Fast Fourier Transform, Discrete Cosine Transform, Wavelet Transforms, Smoothing and Sharpening with Frequency Domain filters, Homomorphic filtering, Pseudo Color Image Enhancement, Introduction to Image Restoration.</p>	8
<p>Module – III Detection of Discontinuities, Point Detection, Line detection, Edge Detection, Thresholding , Optimal Global and Adaptive thresholding, Region-based Segmentation, Textural Images, Textural Feature extraction from Co-occurrence matrices, Chain codes, Signatures, Boundary Segments, Skeletons, Boundary Descriptors, Regional Descriptors.</p>	8
<p>Module – IV Fundamentals of image compression, Redundancy, Image Compression Models, Coding Theorems, Error-free Compression techniques like Variable-length Coding and Lossless Predictive Coding, Lossy Compression techniques like Lossy Predictive Coding and Wavelet Coding, Image Compression Standards.</p>	8
<p>Module – V Fundamentals of Video Coding- Inter-frame redundancy, motion estimation techniques – full-search, fast search strategies, forward and backward motion prediction, frame classification – I, P and B; Video sequence hierarchy – Group of pictures, frames, slices, macro-blocks and blocks; Elements of a video encoder and decoder; Video coding standards – MPEG and H.26X, Introduction to Video Segmentation.</p>	8

Text Books:

1. Digital Image Processing. 2/E by Rafael C. Gonzalez and Richard E. Woods. Pearson Education.
2. Digital Image Processing and Analysis. by B. Chanda and D. Dutta Mujumdar PHI

- Ed. Al Bovik ,”Handbook of Image and Video Processing”, 2nd Edition, Academic Press, 2000.

Reference Books:

- Fundamentals of Digital Image Processing. By Anil K. Jain, PHI Publication
- Image Processing, Analysis and Machine Vision. Milan Sonka and Vaclav Hlavac.
- A. M. Tekalp, “Digital Video Processing”, 2nd Edition, Prentice Hall, 2015.

Gaps in the Syllabus (to meet Industry/Profession requirements)

NA

POs met through Gaps in the Syllabus

NA

Topics beyond syllabus/Advanced topics/Design

Teaching through Research paper

POs met through Topics beyond syllabus/Advanced topics/Design

2

Course Outcome (CO) Attainment Assessment Tools & Evaluation Procedure

Direct Assessment

Assessment Tool	% Contribution during CO Assessment
First Quiz	10
Mid Semester Examination	25
Second Quiz	10
Teacher’s Assessment	5
End Semester Examination	50

Indirect Assessment

- Students’ Feedback on Course Outcome.

Mapping of Course Outcomes onto Program Outcomes

Course Outcome	Program Outcomes (POs)												Program Specific Outcomes (PSOs)		
	1	2	3	4	5	6	7	8	9	10	11	12	13	14	15
CO1	2	3		3	1				1	2		2	1	2	2
CO2	2	3		3	1				1	2	1	2	1	2	3
CO3	2	3	2	3	1				1	2	1	2	2	3	3
CO4	2	2	2	2	1				1	2	1	2	2	2	3
CO5	3	2	1	1	2				1	1	1	2	3	3	3

Correlation Levels 1, 2 or 3 as defined below:

1: Slight (Low) 2: Moderate (Medium) 3: Substantial (High)

Mapping Between COs and Course Delivery (CD) methods

CD Code	Course Delivery Methods	Course Outcome	Course Delivery Method Used
CD1	Lecture by use of Boards/LCD Projectors	CO1	CD1, CD2, CD 8
CD2	Tutorials/Assignments	CO2	CD1 and CD9
CD3	Seminars	CO3	CD1, CD2 and CD3
CD4	Mini Projects/Projects	CO4	CD1 and CD2
CD5	Laboratory Experiments/Teaching Aids	CO5	CD1, CD2, CD9
CD6	Industrial/Guest Lectures		
CD7	Industrial Visits/In-plant Training		
CD8	Self- learning such as use of NPTEL Materials and Internets		
CD9	Simulation		

COURSE INFORMATION SHEET

Wireless Sensor Networks

Course Code: EC433 R1

Course Title: Wireless Sensor Networks

Pre-requisite(s): Knowledge of digital electronics, probability theory, basic understanding of communication system.

Co-requisite(s):

Credits: L: 3 T: 0 P: 0 C:3

Class schedule per week: 03 Class:

B. Tech.

Semester / Level: Seventh/Fourth

Branch: Electronics & Communication Engineering Name

of Teacher:

Course Objectives

This course envisions to impart to students to:

51.	An understanding of the concept of wireless sensor network and its major challenges.
52.	An understanding of WSN architecture and its design principles.
53.	Fundamental understanding on MAC protocols.
54.	Fundamental understanding on routing protocols.
55.	An ability to design and provide solutions for practical low cost, energy efficient, reliable and secure wireless sensor network.

Course Outcomes

After the completion of this course, students will be able to:

CO1	Have an ability to evaluate wireless sensor network based on its performance and minimize the design challenges.
CO2	Have an ability to demonstrate several architectures of WSN and provide a new design solutions according to the required applications.
CO3	Have an ability to design several MAC protocols for WSNs.
CO4	Have an ability to design several Routing and transport protocols for WSNs.
CO5	Have an ability to provide practical solutions and apply the subject expertise for the welfare of society.

SYLLABUS

MODULE	(NO. OF LECTURE HOURS)
<p>Module – I INTRODUCTION TO WIRELESS SENSOR NETWORKS Fundamentals of Wireless Communication Technology, The Electromagnetic Spectrum, Radio propagation Mechanisms, Characteristics of the Wireless Channel, mobile ad hoc networks (MANETs) and wireless sensor networks (WSNs) :concepts and architectures, Applications of Ad Hoc and Sensor networks, Design Challenges in Ad hoc and Sensor Networks.</p>	<p>10</p>
<p>Module – II SINGLE NODE AND NETWORK ARCHITECTURE single node architecture: hardware and software components of a sensor node , WSN Network Architecture: typical network architectures-data relaying and aggregation strategies, Energy consumption of sensor nodes, Operating system and execution environments, sensor network scenarios, Optimization goals and figures of merit, Design principles of WSNs</p>	<p>7</p>
<p>Module – III MAC PROTOCOLS FOR WIRELESS SENSOR NETWORKS Fundamental of MAC protocols, MAC protocols for WSNs, Low duty cycle protocols and wakeup concepts, contention based and scheduled based protocols (LEACH, SMACS, and TRAMA), IEEE 802.15.4 MAC protocols, Topology control and clustering.</p>	<p>7</p>
<p>Module – IV ROUTING AND TRANSPORT CONTROLS PROTOCOL Routing challenges and design issues in WSNs, Wireless network routing protocols, Energy efficient unicast routing, energy efficient broadcast /multicast routing, Geographical routing, traditional transport control protocols, Design issues of transport control protocols, CODA, ESRT, RMST, PSFQ, GRAUDA and Ad hoc Transport protocols (ATP)</p>	<p>10</p>
<p>Module – V LOCALIZATION AND POSITIONING: Properties of localization and positioning procedures, possible approaches: Proximity, Trilateration and Triangulation, Mathematical basics for the lateration problem, single hop localization, positioning in multihop environment.</p>	<p>6</p>

Text Books:

1. Kazem Sohraby, Daniel Minoli, Taieb Znati, “Wireless Sensor Networks’, John Wiley & Sons Inc. Publication, 2007
2. Holger Karl, and Andreas Willig, “Protocols and Architectures for Wireless Sensor Networks” John Wiley & Sons Inc. Publication.

Gaps in the Syllabus (to meet Industry/Profession requirements)

POs met through Gaps in the Syllabus:

Topics beyond syllabus/Advanced topics/Design :

POs met through Topics beyond syllabus/Advanced topics/Design:

Course Outcome (CO) Attainment Assessment Tools & Evaluation Procedure:PO1

Direct Assessment

Assessment Tool	% Contribution during CO Assessment
First Quiz	10
Mid Semester Examination	25
Second Quiz	10
Teacher's Assessment	5
End Semester Examination	50

Indirect Assessment

1. Students' Feedback on Course Outcome.

Mapping of Course Outcomes onto Program Outcomes

Course Outcome	Program Outcomes (POs)												Program Specific Outcomes (PSOs)		
	1	2	3	4	5	6	7	8	9	10	11	12	13	14	15
CO1	3	1											3	2	1
CO2	3	3				1							3	2	2
CO3	3	3				1							3	2	1
CO4	3	3				1							3	2	3
CO5	3	3	1	3		1	1					2	3	2	2

Correlation Levels 1, 2 or 3 as defined below:

- 1: Slight (Low) 2: Moderate (Medium) 3: Substantial (High)

Mapping Between COs and Course Delivery (CD) methods

CD Code	Course Delivery Methods	Course Outcome	Course Delivery Method Used
CD1	Lecture by use of Boards/LCD Projectors	CO1	CD1, CD8
CD2	Tutorials/Assignments	CO2	CD1 ,CD8
CD3	Seminars	CO3	CD1, CD8
CD4	Mini Projects/Projects	CO4	CD1, CD8
CD5	Laboratory Experiments/Teaching Aids	CO5	CD1,CD8
CD6	Industrial/Guest Lectures		
CD7	Industrial Visits/In-plant Training		
CD8	Self- learning such as use of NPTEL Materials and Internets		
CD9	Simulation		

COURSE INFORMATION SHEET
Nanoelectronics

Course code: EC435 R1

Course title: Nanoelectronics

Pre-requisite(s): EC101 Basics of Electronics and Communication Engineering, EC201 Electronic Devices Co- requisite(s):

Credits: L: 3 T: 0 P: 0 C: 3

Class schedule per week: 03 **Class:** B.
Tech.

Semester / Level: VI/03

Branch: ECE **Name**
of Teacher:

Course Objectives

This course enables the students to:

1	Understand the theory of Classical Particles, Classical Waves, Quantum Particles, Quantum Mechanics of Electrons, Free and Confined electrons.
2	Interpret the various aspects of Electrons Subject to a Periodic Potential – Band Theory of Solids and apply the perceived knowledge.
3	Appraise and analyse the characteristics of the theory of Coulomb Blockade and the Single-Electron Transistor.
4	Perceive models of Semiconductor Quantum Wells, Quantum Wires and Quantum Dots and evaluate their characteristics.
5	Apprehend Nanowires, Ballistic Transport and Spin Transport models and develop/integrate them for their applications.

Course Outcomes

After the completion of this course, a student will be able to:

CO1	Describe and illustrate the theory of Classical Particles, Classical Waves, Quantum Particles, Quantum Mechanics of Electrons, Free and Confined electrons.
CO2	Sketch and explain various aspects of Electrons Subject to a Periodic Potential – Band Theory of Solids.
CO3	Illustrate with the sketch of theory of Coulomb Blockade and the Single-Electron Transistor, diagram their characteristics and analyse them.
CO4	Appraise the models of Semiconductor Quantum Wells, Quantum Wires and Quantum Dots, schematize their characteristics, assess and summarize their features.
CO5	Schematize the structure of Nanowires, and and design Field Effect Transistors that have carrier with Ballistic Transport and Spin Transport. Schematize their characteristics and prepare an inference.

SYLLABUS

MODULE	(NO. OF LECTURE HOURS)
<p>Module – I Classical Particles, Classical Waves, Quantum Particles, Quantum Mechanics of Electrons, Free and Confined electrons: Introduction to nanoelectronics, Origins of Quantum Mechanics, Light as Wave, Light as a Particle, Electrons as Particles, Electrons as Waves, Wave packets and Uncertainty, General Postulates of Quantum Mechanics, Time-Independent Schrodinger’s Equation, Free Electrons, Free Electron Gas theory of Metals, Electrons Confined to a Bounded Region of Space and Quantum Numbers, Quantum Dots, Wires and Wells.</p>	8
<p>Module – II Electrons Subject to a Periodic Potential – Band Theory of Solids: Crystalline Materials, Electrons in a Periodic Potential, Kronig-Penney Model of Band Structure, Band theory of Solids, Graphene and Carbon Nanotubes, Tunneling Through a potential Barrier, Potential Energy Profiles for Material Interfaces, Applications of Tunnelling.</p>	8
<p>Module – III Coulomb Blockade and the Single-Electron Transistor: Coulomb Blockade, The Single-Electron Transistor, Single Electron Transistor logic; Other SET and FET Structures: Carbon Nanotube Transistors (FETs and SETs), Semiconductor Nanowire FETs and SETs, Molecular SETs and Molecular Electronics; Density of States, Classical and Quantum Statistics.</p>	8
<p>Module – IV Models of Semiconductor Quantum Wells, Quantum Wires and Quantum Dots: Semiconductor Heterostructures and Quantum Wells, Quantum Wires and Nanowires; Quantum Dots and Nanoparticles, Fabrication Techniques for Nanostructures: Lithography, Nanoimprint Lithography, Split-Gate Technology, Self-Assembly.</p>	8
<p>Module – V Nanowires, Ballistic Transport and Spin Transport: Classical and Semiclassical Transport, Ballistic Transport, Carbon Nanotubes and Nanowires, Transport of Spin, and Spintronics: The Transport of Spin,-Spintronic Devices and Applications.</p>	8

Textbooks:

1. George W. Hanson, Fundamentals of Nanoelectronics, Pearson, 2009.
2. W. Ranier, Nanoelectronics and Information Technology (Advanced Electronic Material and Novel Devices), Wiley-VCH, 2003.
3. K.E. Drexler, Nanosystems, Wiley, 1992.

Reference books:

1. John H. Davies, The Physics of Low-Dimensional Semiconductors, Cambridge University Press, 1998.
2. Charles P. Poole, F. J. Owens, Introduction to Nanotechnology, Wiley, 2003.

Gaps in the syllabus (to meet Industry/Profession requirements):

1. Hands-on-practical for Device fabrication.

POs met through Gaps in the Syllabus:

10

Topics beyond syllabus/Advanced topics/Design:

1. TFET
2. MTJ
3. Memristor
4. RTD.

POs met through Topics beyond syllabus/Advanced topics/Design:

10

Course Outcome (CO) Attainment Assessment Tools and Evaluation Procedure Direct Assessment

Assessment Tool	% Contribution during CO Assessment
First Quiz	10
Mid Semester Examination	25
Second Quiz	10
Teacher's Assessment	5
End Semester Examination	50

Indirect Assessment

1. Students' Feedback on Course Outcome.

Mapping of Course Outcomes onto Program Outcomes

Course Outcome	Program Outcomes (POs)												Program Specific Outcomes (PSOs)		
	1	2	3	4	5	6	7	8	9	10	11	12	13	14	15
CO1	3	3	1	3	3	1	1			3		3	3	2	1
CO2	3	3	2	3	3	3	1			3		3	3	2	1
CO3	3	3	1	3	3	3	1			3		3	3	2	1
CO4	3	3	1	3	3	1	1			3		3	3	2	1
CO5	3	3	2	3	3	3	1			3		3	3	2	1

Correlation Levels 1, 2 or 3 as defined below:

1: Slight (Low) 2: Moderate (Medium) 3: Substantial (High)

Mapping Between COs and Course Delivery (CD) methods

CD Code	Course Delivery Methods	Course Outcome	Course Delivery Method Used
CD1	Lecture by use of Boards/LCD Projectors	CO1	CD1, CD7, CD 8
CD2	Tutorials/Assignments	CO2	CD1 and CD9
CD3	Seminars	CO3	CD1, CD2 and CD3
CD4	Mini Projects/Projects	CO4	CD1 and CD2
CD5	Laboratory Experiments/Teaching Aids	CO5	CD1 and CD2
CD6	Industrial/Guest Lectures		
CD7	Industrial Visits/In-plant Training		
CD8	Self- learning such as use of NPTEL Materials and Internets		
CD9	Simulation		

COURSE INFORMATION SHEET
Sensors and Transducers

Course Code: EC259 R1

Course title: **Sensors and Transducers (Open elective)**

Pre-requisite(s):

Co- requisite(s):

Course type: Elective

Credits: L: 3 T: 0 P: 0

Class schedule per week: 03

Class: B.E

Semester / Level: VI

Branch: ECE Name

of Teacher:

Course Objectives

This course envisions to impart to students to:

11.	To describe the operation of various sensors and their application
12.	To select an appropriate sensor for a given application
13.	Design a smart sensor using conventional sensors and microcontroller
14.	Compare analog and digital transducer.
15.	To discuss the latest technology in sensor development

Course Outcomes

After the completion of this course, students will be able to:

CO1	Understand the principle of operation of different sensors and their applications
CO2	Classify sensors on different basis
CO3	Differentiate between smart sensor and conventional sensor
CO4	Demonstrate the operation of various digital transducer
CO5	Be updated on the recent trends in sensor technologies.

SYLLABUS

MODULE	(NO. OF LECTURE HOURS)
<p>Module – I</p> <p>Introduction Introduction about sensors and transducers, Principles of operation and their classification, characteristics of sensors, Errors in measurement.</p>	6
<p>Module – II</p> <p>Resistive and Inductive Transducer Resistive transducers: Potentiometers, metal and semiconductor strain gauges and signal conditioning circuits, strain gauge applications: load and torque measurement, RTD, Thermistor, LDR, Self and mutual inductive transducers, LVDT, RVDT, eddy currents transducer</p>	10
<p>Module – III</p> <p>Capacitive and Piezoelectric transducer The parallel plate capacitive sensor, variable permittivity capacitive sensor, stretched diaphragm variable capacitive transducer, piezoelectric transducers and their signal conditioning, photoelectric transducers, Hall Effect sensors.</p>	10
<p>Module – IV</p> <p>Smart Sensor Principle, design approach, interface design, configuration supports, communication in smart transducer network. HART protocol.</p>	8
<p>Module – V</p> <p>Recent trends in sensor technology Digital transducer, Principles and applications of Fibre optic sensor, MEMS sensor, Bio sensor, Silicon sensor, sensors for robotics.</p>	6

Text Books:

1. Sensors and Transducers, by D. Patranabis. 2nd Edition
2. Elctrical & Electronics Measurements and Instrumentation by A.K Sawhney, Dhanpat Rai & Sons.
3. Transducers and Instrumentation, by Murthy D. V. S., Prentice Hall, 2nd Edition, 2011.

Reference Books:

1. Sensor and signal conditioning by John G. Webster, Wiley Inter Science, 2nd edition, 2008

Gaps in the syllabus (to meet Industry/Profession requirements): N/A

POs met through Gaps in the Syllabus: PO8 will be met though report-writing/presentationbased assignment

Topics beyond syllabus/Advanced topics/Design: Teaching through paper/ latest standards in data communication

POs met through Topics beyond syllabus/Advanced topics/Design: Teaching through paper

Course Outcome (CO) Attainment Assessment Tools & Evaluation Procedure

Direct Assessment

Assessment Tool	% Contribution during CO Assessment
First Quiz	10
Mid Semester Examination	25
Second Quiz	10
Teacher's Assessment	5
End Semester Examination	50

Indirect Assessment

1. Students' Feedback on Course Outcome.

Mapping of Course Outcomes onto Program Outcomes

Course Outcome	Program Outcomes (POs)												Program Specific Outcomes (PSOs)		
	1	2	3	4	5	6	7	8	9	10	11	12	13	14	15
CO1	3	2	3	3		3	1	2	3	3	3	3	2	2	1
CO2	2	3	3	3		3	1	2	3	3	3	2	2	2	1
CO3	2	3	3	3		3	1	3	3	3	3	2	2	2	1
CO4	2	2	3	3	1	3	1	2	3	3	3	2	2	2	1
CO5	2	3	3	2	1	3	1	2	3	3	3	2	2	2	1

Correlation Levels 1, 2 or 3 as defined below:

1: Slight (Low) 2: Moderate (Medium) 3: Substantial (High)

Mapping Between COs and Course Delivery (CD) methods

CD Code	Course Delivery Methods	Course Outcome	Course Delivery Method Used
CD1	Lecture by use of Boards/LCD Projectors	CO1	CD1, and CD 8
CD2	Tutorials/Assignments	CO2	CD1, and CD 8
CD3	Seminars	CO3	CD1, and CD 8
CD4	Mini Projects/Projects	CO4	CD1, and CD 8
CD5	Laboratory Experiments/Teaching Aids	CO5	CD1, and CD 8
CD6	Industrial/Guest Lectures		
CD7	Industrial Visits/In-plant Training		
CD8	Self- learning such as use of NPTEL Materials and Internets		
CD9	Simulation		

COURSE INFORMATION SHEET
Introduction to Communication System

Course Code: EC321 R1

Course Title: Introduction to Communication System (Open elective)

Pre-requisite(s): Good understanding of mathematical tools like integration, differentiation etc.

Co- requisite(s):

Credits: L: 3 T: 0 P: 0

Class schedule per week: 03 Class:

B. Tech.

Semester / Level: OE/Three

Branch: Electronics & Communication Engineering Name

of Teacher:

Course Objectives

This course envisions to impart to students to:

1	Explain basics of analog and digital communication system and modulation-demodulation schemes
2	Explain the method to design analog and digital modulation-demodulation system
3	Explain the concept of sampling, quantization and coding required for various Pulse modulation schemes.
4	Explain the concept of multiplexing schemes
5	Explain to evaluate the performance of communication system in the presence of noise.

Course Outcomes

After the completion of this course, students will be able to:

CO1	Demonstrate an understanding on communication system and representation of signals.
CO2	Demonstrate an understanding on different methods of Analog and Digital modulation and demodulation schemes.
CO3	Demonstrate an understanding on design, operation and applications of Analog and Digital modulation and demodulation schemes
CO4	Demonstrate an understanding on Multiplexing Scheme and Heterodyne receiver
CO5	Evaluate the performance of communication system in the presence of noise.

SYLLABUS

MODULE	(NO. OF LECTURE HOURS)
<p>Module – I Overview of electronic communication systems, need for modulation, amplitude modulation, generation and detection of AM waves, DSB-SC modulation, generation and detection of DSB-SC waves, SSB modulation and demodulation, comparison between AM, DSB-SC and SSB, frequency division multiplexing, noise in communication system, signal to noise ratio, Shannon’s theorem, channel capacity, bandwidth S/N trade-off.</p>	10
<p>Module – II Angle modulation, frequency modulation and phase modulation, NBFM, WBFM, generation of FM wave, demodulation of FM wave, superheterodyne receiver, Frequency Division Multiplexing.</p>	10
<p>Module – III Pulse modulation: sampling theorem, pulse amplitude modulation, time division multiplexing, PAM modulator and demodulator, pulse duration modulation, PDM modulator and demodulator, pulse position modulation, PPM modulator and demodulator. Analog to digital conversion:, quantization process, pulse code modulation, differential pulse code modulation, delta modulation</p>	7
<p>Module – IV Digital modulation and transmission: BFSK, DPSK, QPSK, M-ary PSK, QASK, BFSK, M-ary FSK, MSK, pulse shaping to reduce inter-channel and inter-symbol interference. Spread spectrum modulation and its use, PN sequence generation and its characteristics,</p>	6
<p>Module – V Noise in communication system, various types of noise, equivalent noise band width, noise temperature, signal to noise ratio, noise figure, shannon’s theorem, channel capacity, bandwidth S/N trade-off, mutual information and channel capacity</p>	7

Text Books:

1. Herbert Taub, Donald L Schilling and Gautam Saha “Communication Systems” McGraw Hill Education (India), pvt. Ltd., New Delhi, 4th edition, 2013.

Reference Books:

1. Simon Haykin, “Communication Systems” Wiley, 4th edition, 2001.
2. D. Roddy & J. Coolen, “Electronics Communication”, 4th Edition, PHI, 2005

Gaps in the Syllabus (to meet Industry/Profession requirements)**POs met through Gaps in the Syllabus:****Topics beyond syllabus/Advanced topics/Design****POs met through Topics beyond syllabus/Advanced topics/Design: PO2****Course Outcome (CO) Attainment Assessment Tools & Evaluation Procedure****Direct Assessment**

Assessment Tool	% Contribution during CO Assessment
First Quiz	10
Mid Semester Examination	25
Second Quiz	10
Teacher’s Assessment	5
End Semester Examination	50

Indirect Assessment

1. Students’ Feedback on Course Outcome.

Mapping of Course Outcomes onto Program Outcomes

Course Outcome	Program Outcomes (POs)												Program Specific Outcomes (PSOs)		
	1	2	3	4	5	6	7	8	9	10	11	12	1	2	3
CO1	3	2	2	1	-	-	-	-	-	-	-	2	3	2	1
CO2	3	3	3	3	2	-	-	-	-	-	-	1	3	2	2
CO3	3	3	3	3	2	-	-	-	-	-	-	1	3	2	1
CO4	3	3	3	3	3	-	-	-	-	-	-	1	3	2	3
CO5	3	3	3	3	2	-	-	-	-	-	-	1	3	2	2

Correlation Levels 1, 2 or 3 as defined below:

- 1: Slight (Low)
- 2: Moderate (Medium)
- 3: Substantial (High)

Mapping Between COs and Course Delivery (CD) methods

CD Code	Course Delivery Methods	Course Outcome	Course Delivery Method Used
CD1	Lecture by use of Boards/LCD Projectors	CO1	CD1, CD8
CD2	Tutorials/Assignments	CO2	CD1 ,CD8
CD3	Seminars	CO3	CD1, CD8
CD4	Mini Projects/Projects	CO4	CD1, CD8
CD5	Laboratory Experiments/Teaching Aids	CO5	CD1,CD8
CD6	Industrial/Guest Lectures		
CD7	Industrial Visits/In-plant Training		
CD8	Self- learning such as use of NPTEL Materials and Internets		
CD9	Simulation		

COURSE INFORMATION SHEET
Introduction to MEMS

Course code: EC361 R1

Course title: Introduction to MEMS (open elective)

Pre-requisite(s): Fundamental concept of Mechanical Engg, Electrical Engg, Instrumentation, Physics & Material Science

Co- requisite(s): Basics of transducer and sensor

Credits: L:3 T :0 P :0 C:3

Class schedule per week: 03/week

Class: B. Tech

Semester / Level: Seventh

Branch: ECE Name

of Teacher:

Course Objectives

This course enables the students:

1.	To understand the Fundamental concepts of MEMS technology
2.	To classify different micro sensors and micro actuators
3.	To acquire basic knowledge about application of MEMS in different areas and physical modeling used in MEMS Design.
4.	To understand different Microfabrication techniques, MEMS materials and design issues
5.	To understand the integration and packaging of MEMS devices.

Course Outcomes

After the completion of this course, students will be able to :

CO1.	Demonstrate knowledge on fundamental principles and concepts of MEMS Technology
CO2.	Analyze various techniques for building micro-devices in silicon, polymer, metal and other MEMS materials
CO3.	Apply different fabrication methodology used in MEMS devices.
CO4.	Analyze micro-systems technology for technical feasibility as well as practicality using modern tools and relevant simulation software to perform design and analysis.
CO5.	Design and analyze Different MEMS Devices using physical, chemical, mechanical and electrical properties of MEMS material. and principles involved in the design and operation of micro-devices

SYLLABUS

MODULE	(NO. OF LECTURE HOURS)
<p>Module – I</p> <p>Introduction : The History of MEMS Development ,Intrinsic characteristics of MEMS .</p> <p>Introduction to microfabrication.: Essential overview of frequently used micro fabrication processes. Thin film deposition techniques ,wafer bonding Silicon Based MEMS processes ,MEMS Materials</p>	10
<p>Module – II</p> <p>Essential Electrical and Mechanical Concepts: General Scalar relation between Tensile stress and strain, Mechanical properties of silicon and related thin films, Flexural Beam bending Analysis ,Dynamic System ,Resonant Frequency and quality factor ,Electromechanical and Direct Analogy in Electrical and Mechanical domain.</p>	9
<p>Module – III</p> <p>Sensing and Actuation schemes: Electrostatic Sensors and Actuators, Thermal sensors and actuators, Piezoresistive Sensors, Piezoelectric Sensors and Actuators, Magnetic Actuators.</p>	8
<p>Module – IV</p> <p>Introduction of MEMS switches .MEMS Inductor and MEMS capacitor – classification and design issues. MEMS Packaging and Integration. . Role of MEMS packages.</p>	7
<p>Module – V</p> <p>Case studies for selected MEMS Products: Blood Pressure Sensor, Microphone, Accelerometer, Performance and Accuracy</p>	6

Text Books:

1. Foundations of MEMS by Chang Liu, Second Edition ,Pearson, ISBN 978-81-317-6475-6
2. RF MEMS and Their Applications, Vijay K.Varadan, K.J.Vinoy and K.A.Jose, Wiley India Pvt Ltd.,Wiley India Edition, ISBN 978-81-265-2991-9

Reference Book:

1. MarcMadou, Fundamentals of Microfabrication by, CRC Press, 1997. Gregory Kovacs, Micromachined Transducers Sourcebook WCB McGraw-Hill, Boston, 1998.
2. M.-H. Bao, Micromechanical Transducers: Pressure sensors, accelerometers, and gyroscopes by Elsevier, New York, 2000.

Gaps in the Syllabus (to meet Industry/Profession requirements)

By attending workshop and hands on training in Industry or Institute -IISC Bangalore, IITs Through INUP **The Indian Nanoelectronics Users Program**

POs met through Gaps in the Syllabus 3,5,9

Topics beyond syllabus/Advanced topics/Design :

Simulation and Modelling and analysis , MEMS device characterization-

POs met through Topics beyond syllabus/Advanced topics/Design

2,3,4,12

Course Outcome (CO) Attainment Assessment tools & Evaluation procedure

Direct Assessment

Assessment Tool	% Contribution during CO Assessment
Mid SEM Examination Marks	25
End SEM Examination Marks	50
Quizzes	10+10
Assessment by teacher	5

Indirect Assessment

2. Students' Feedback on Course Outcome.

Mapping of Course Outcomes onto Program Outcomes

Course Outcome	Program Outcomes (POs)												Program Specific Outcomes (PSOs)		
	1	2	3	4	5	6	7	8	9	10	11	12	13	14	15
CO1	3	3	3	1					2	2			3	1	1
CO2	3	3	3	3	2		2		2	3	1		3	1	1
CO3		3	3	1	3		3		2	3			3	2	1
CO4	3	3	3	1			1					2	3	2	1
CO5	3	1			1				1		1		3	2	1

Correlation Levels 1, 2 or 3 as defined below:

1: Slight (Low) 2: Moderate (Medium) 3: Substantial (High)

Mapping Between COs and Course Delivery (CD) methods

CD Code	Course Delivery Methods	Course Outcome	Course Delivery Method Used
CD1	Lecture by use of Boards/LCD Projectors	CO1	CD1, CD2, CD7,CD 8
CD2	Tutorials/Assignments	CO2	CD2,CD5, CD4
CD3	Seminars	CO3	CD2, CD6,CD 8,CD9
CD4	Mini Projects/Projects	CO4	CD4,CD5,CD6 ,CD7
CD5	Laboratory Experiments/Teaching Aids	CO5	CD1,CD6 ,CD8,
CD6	Industrial/Guest Lectures		
CD7	Industrial Visits/In-plant Training		
CD8	Self- learning such as use of NPTEL Materials and Internets		

COURSE INFORMATION SHEET
Introduction to Signal Processing

Course Code: EC437 R1

Course Title: Introduction to Signal Processing (Open elective)

Pre-requisite(s): NIL Co- requisite(s):

Credits: L: 3 T: 0 P: 0

Class schedule per week: 03 Class:

B. Tech.

Semester / Level: 7

**Branch: Electronics and Communication Engineering Name
of Teacher:**

Course Objectives

This course envisions to impart students to:

46.	Understand the fundamentals of signal and system.
47.	Interpret the different transform techniques of signal processing.
48.	Understand time domain and frequency domain signal analysis
49.	Demonstrate the analog and digital filtering process.
50.	Explain the concept of random variables and parameter estimation in signal processing.

Course Outcomes

After the completion of this course, students will be able to:

CO1	Explain the fundamentals of signal and system
CO2	Interpret the different transform techniques of signal processing.
CO3	Implement the time domain and frequency domain signal analysis for particular applications.
CO4	Design and apply the analog and digital filters.
CO5	Apply digital filtering and signal estimation to retrieve information from noisy data.

SYLLABUS

MODULE	(NO. OF LECTURE HOURS)
<p>Module – I</p> <p>Introduction and Basics: Signals and Systems; Classification of Signals, System Properties; Linear Algebra Basics-Vectors, Orthogonality, Eigenvalues and Eigenvectors.</p>	6
<p>Module – II</p> <p>Continuous Signals and Systems: Laplace Transform, Fourier Transform, Transfer Functions, Causality and Stability, Poles/Zeros; Differential Equations, Steady State and Transient Responses, and Convolution Integral.</p>	8
<p>Module – III</p> <p>Discrete-Time Signals and Systems: LTI Systems; Z-transform; Digital filters; Difference Equations; Causality and stability; Convolution and Correlation; Discrete Fourier Transform (DFT), FFT and Window Function; Frequency Analysis of Signals and Systems; Data Acquisition: Sampling theorem; Sampling of Bandpass Signals; Quantization; A/D conversion; D/A conversion; Sampling and Reconstruction; Interpolation and Decimation.</p>	10
<p>Module – IV</p> <p>Digital Filter Design: Butterworth, Elliptic, Chebyshev low-pass filters. Filter Realizations; Conversion to high-pass, band-pass, band-stop filters. Discrete-time filters: IIR and FIR. Linear phase filters. Frequency sampling filters.</p>	8
<p>Module – V</p> <p>Probability and Random Signals: Random variables; probability density functions (PDFs); Moments and Cumulants; Multivariate distributions; Time averages, Ensemble averages, Autocorrelation functions, Crosscorrelation function; Estimation of parameters of random signals; Linear prediction; Auto-regressive model; Nonlinear models of signals; Analysis of Nonstationary signals</p>	8

Text Books:

2. Oppenheim, A. S. Willsky and H. Nawab, "Signals and Systems," 2nd Ed., Prentice-Hall, 1996.
3. Papoulis and S. U. Pillai, "Probability, Random Variables, and Stochastic Processes," McGraw Hill, 2001.

Reference Books:

1. 1. A. V. Oppenheim, Ronald W. Schafer and John R. Buck, "Discrete-Time Signal Processing," 2nd Ed., Prentice Hall, 1999.
2. J. G. Proakis, and D. K. Manolakis, "Digital Signal Processing," 4th Ed., Prentice Hall, 2006.

Gaps in the Syllabus (to meet Industry/Profession requirements)

NA

POs met through Gaps in the Syllabus**Topics beyond syllabus/Advanced topics/Design**

Teaching through research paper

POs met through Topics beyond syllabus/Advanced topics/Design**Course Outcome (CO) Attainment Assessment Tools & Evaluation Procedure****Direct Assessment**

Assessment Tool	% Contribution during CO Assessment
First Quiz	10
Mid Semester Examination	25
Second Quiz	10
Teacher's Assessment	5
End Semester Examination	50

Indirect Assessment

1. Students' Feedback on Course Outcome.

Mapping of Course Outcomes onto Program Outcomes

Course Outcome	Program Outcomes (POs)												Program Specific Outcomes (PSOs)		
	1	2	3	4	5	6	7	8	9	10	11	12	13	14	15
CO1	2	2		2	1				1	1	1	2			
CO2	3	3		2	2				1	2	1	2			
CO3	2	3	1	1	3				1	1	1	2			
CO4	3	3		2	3				1	1	1	2			
CO5	3	2	1	1	2				1	1	1	2			

Correlation Levels 1, 2 or 3 as defined below:

1: Slight (Low) 2: Moderate (Medium) 3: Substantial (High)

Mapping Between COs and Course Delivery (CD) methods

CD Code	Course Delivery Methods	Course Outcome	Course Delivery Method Used
CD1	Lecture by use of Boards/LCD Projectors	CO1	CD1, CD7, CD 8
CD2	Tutorials/Assignments	CO2	CD1 and CD9
CD3	Seminars	CO3	CD1, CD2 and CD3
CD4	Mini Projects/Projects	CO4	CD1 and CD2
CD5	Laboratory Experiments/Teaching Aids	CO5	CD1 and CD2
CD6	Industrial/Guest Lectures		
CD7	Industrial Visits/In-plant Training		
CD8	Self- learning such as use of NPTEL Materials and Internets		
CD9	Simulation		

COURSE INFORMATION SHEET

Embedded System Design

Course code: EC323 R1

Course title: Embedded System Design

Pre-requisite(s): Digital Electronics, Signal Processing, Communication Systems.

Co- requisite(s):

Credits: L: 3 T: 0 P: 0

Class schedule per week: 3 L

Class: B.Tech

Semester / Level: V

Branch: ECE

Name of Teacher:

Course Objectives

This course enables the students to:

A.	Define the fundamental of embedded systems
B.	Show the correlation between hardware & software in embedded system
C.	Show the application of embedded system in present market
D.	Design the highly secure optimized embedded systems
E.	Develop the suitable software for embedded system

Course Outcomes

After the completion of this course, students will be able to:

1.	Recognize the interfacing and integration of component in SoC.
2.	Design the highly secure ATM.
3.	Develop the programmable kit to check the entire components in a board.
4.	Develop the embedded systems & corresponding software as per demand of current market.

Syllabus

Module 1:

Introduction to Embedded System:

The concept of embedded systems design, Embedded microcontroller cores, embedded memories, Examples of embedded systems, system partitioning, partition by feature, partition with CPU, finding missing interrupts.

Module 2:

Technological aspects of embedded systems:

Interfacing between analog and digital blocks, signal conditioning, digital signal processing, ISR Debugging, Measuring performance, Guesstimatching performance, a poor man's performance analyzer, RTOS.

Module 3:

Sub-System Design & Interfacing:

Sub-system interfacing, interfacing with external systems, user interfacing; hacking peripheral driver, selecting stack size, the curse of Malloc(), Banking, logical to physical, hardware issues, software, predicting ROM requirements, RAM diagnostic, Inverting bits, noise issues, notes of software prototyping.

Module 4:**Design Trade Off:**

Design tradeoffs due to process compatibility, thermal considerations; Debug gable design, test point galore, resistors, unused inputs, clocks, reset, small CPUs, watchdog timers, making PCBs, changing PCB, Planning.

Module 5:**Software aspects of embedded systems:**

Real time programming languages and operating systems for embedded systems; Emulators, BDMs, ROM Monitors, ROM emulators, Oscilloscopes, Scoping Tricks, Fancy tools and big bucks, Tool woes, reliable connections, nonintrusive myths, add debugging resources, ROM burnout, speed up by slowing down.

Text books:

1. J.W. Valvano, "Embedded Microcomputer System: Real Time Interfacing", Brooks/Cole, 2000.
2. Jack Ganssle, "The Art of Designing Embedded Systems", Newnes, 1999.

Reference Books:

1. V.K. Madisetti, "VLSI Digital Signal Processing", IEEE Press (NY, USA), 1995.
2. David Simon, "An Embedded Software Primer", Addison Wesley, 2000.
3. K.J. Ayala, "The 8051 Microcontroller: Architecture, Programming, and Applications", Penram Intl, 1996.

Gaps in the syllabus (to meet Industry/Profession requirements): N/A

POs met through Gaps in the Syllabus: PO8 will cover through paper writing/ technical report writing/ assignments/mini projects

Topics beyond syllabus/Advanced topics/Design : Covered with technical papers related to the course

POs met through Topics beyond syllabus/Advanced topics/Design: Teaching with research papers

Course Delivery methods
Lecture by use of boards/LCD projectors/OHP projectors
Tutorials/Assignments
Seminars
Mini projects/Projects
Laboratory experiments/teaching aids
Industrial/guest lectures
Industrial visits/in-plant training
Self- learning such as use of NPTEL materials and internets
Simulation

COURSE INFORMATION SHEET

Embedded System Design Lab

Course Code: EC324 R1

Course Title: Embedded System Design Lab

Pre-requisite(s): Fundamental knowledge of VLSI Design, Digital Electronics

Co- requisite(s):

Credits: L: 0 T: 0 P: 2 C:1

Class schedule per week: 02 Class:

B. Tech.

Semester / Level: VII

**Branch: Electronics & Communication Engineering Name
of Teacher:**

Course Objectives

This course envisions imparting to students to:

1.	Recognize the programmable hardware and its programming.
2.	Develop an ability to write 8051based assembly language/ C programs.
3.	Write the program for different-2 on-chip peripherals to work with Microcontroller.
4.	Develop industrial potentials to develop product in prototype as per demand of market.
5.	Develop the tools and techniques for complex chip design & debugging

Course Outcomes

After the completion of this course, students will be able to:

CO1	Recognize the concept of programmable hardware and its programming.
CO2	Recognize to write 8051based assembly language/ C programs.
CO3	Write the efficient program for various on-chip peripherals to work with Microcontroller.
CO4	Develop industrial competency to develop product in prototype as per demand of market and capability to debug the complex chip problems.
CO5	Demonstrate the tool and techniques for the design & debugging the complex chip

List of Experiments

1. Design a 2-bit adder using System Generator on Xilinx ISE 10.1i. Synthesize the circuit, download the configuration file to the prototyping board (use Spartan-3E Starter kit) and verify its operation with Chip Scope Pro.
2. Design a 4-bit Johnson counter using Verilog on Xilinx ISE 10.1i. Synthesize the circuit, download the configuration file to the prototyping board (use Xilinx XC9572 CPLD in Milman VLSI Trainer kit) and verify its operation.
3. Design a circuit to implement GCD (greatest common divisor) algorithm using Verilog on Xilinx ISE 8.1i. Synthesize the circuit, download the configuration file to the prototyping board (use Spartan-3E Starter kit) and verify its operation.
4. Develop a digital system to display “DIAT” on a multi-segment LED display panel. The scrolling of the word has to be in the right-to-left direction. Assume each segment of the LED display panel has eight rows and eight columns.
5. Develop a digital system to display digital pulses on pages 1 and 6 of a GLCD. Use both segments and display two cycles in each page. Use the onboard DIP switch for resetting the GLCD.
6. Outline and write a VHDL/Verilog code for designing a 2-bit adder using System Generator. Test your VHDL/Verilog code by simulating it, find error, if any; synthesize the error free RTL code; experiment your design downloading the configuration file into the Xilinx XC9572 CPLD in Milman VLSI Trainer kit /Spartan-3E Starter kit and verify its operation without Chip Scope Pro.
7. Sixteen LEDs are connected to the FPGA in common cathode configuration. Develop VHDL/Verilog code to make the first eight LEDs glow in a downward direction while the other eight LEDs glow in an upward direction. This has to happen five times; then all the LEDs have to blink two times. Simulate your VHDL/Verilog code, find error, if any; synthesize the error free RTL code; experiment your design downloading the configuration file into the Xilinx XC9572 CPLD in Milman VLSI Trainer kit and show the results.
8. Develop a digital system in FPGA to drive a buzzer at different duty cycles 0%, 40%, 80%, and 100% whenever the input (data_in) is ($0 \leq \text{data_in} \leq 10$), ($10 < \text{data_in} \leq 100$), ($100 < \text{data_in} \leq 200$) and ($200 < \text{data_in}$), respectively. Assume that the inputs are given via a port of eight bits. Simulate your VHDL/Verilog code, find error, if any; synthesize the error free RTL code; experiment your design downloading the configuration file into the Xilinx XC9572 CPLD in Milman VLSI Trainer kit and show the results.
9. Develop a digital system in the FPGA to control appliances from a remote station using DTMF (Dual-Tone Multifrequency Decoder) tones as per the following requirements.
 - a) There are nine electrical appliances that have to be controlled.
 - b) DTMF tone “0” has to be used to switch off all the appliances.
 - c) DTMF tone data (1–9) have to be used to select a particular appliance.
 - d) “*” and “#”, that is, A (“1010”) and C (“1100”), have to be used to switch the appliances “on” and “off”, respectively.
10. Develop a FPGA-based digital system to continuously monitor and automatically fill the chemical fluid in a tank. A proximity sensor is placed inside the tank so as to get IR radiation

reflected back to the phototransistor from the chemical fluid surface. The output of the phototransistor is given to an 8-bit A/D convertor. Hence, the fluid level is measured by A/D and given to the FPGA via 8-bit data. The system has to indicate the fluid level in the first row of an LCD and switch on the fluid inlet motor if the level goes below “00001111”.

11. Write a program to read two digital inputs from pins D6 and D7, performs the logical AND, and sets it to D9 pin for output.
12. Write a program to read the analog input from pin A0, multiply it by 10, and set it to the analog output pin DAC0_OUT for output.

Optional Experiments

13. Write a program, so that it can create a sine wave on the analog output pin DAC0_OUT pin.
14. Write a program to read both the accelerometer and the magnetometer values.
15. Write program to read lowercase characters from a computer serial port, convert them to uppercase, and echo them back.
16. Write a program read three integer numbers from computer serial port; numbers are separated by “ , ”.
17. Write a program to read characters from a computer serial port, send them to the device serial interface (D4, D5), and vice versa.
18. Write a program so that one FRDM-K64F board can communicate with another FRDMK64F board (or LPC1768 board) through a serial interface (D4, D5).
19. Write two programs so that the SPI server can read the digital input pin D0 and send a value to SPI clients.
20. Write two programs so that the I2C server can send 10 data to I2C clients.
21. Write a program to read the analog pin A0, and sends the value to CAN1 (Controller Area Network).
22. Write a program to read the analog inputs A0, A1, A2 and display the values as a table in HTTP body message.
23. Write TCP client/server programs so that the server receives the message from the client, changes it to uppercase, then echoes it back to the client.
24. Write UDP client/server programs so that the server reads the digital pin D0 and sends the value to the client.
25. Write a program to continuously read the temperature sensor values and send it to the WebSocket server.

Textbooks:

3. A. Arockia Bazil Raj, “FPGA based embedded system developer's guide”, Taylor & Francis, CRC Press, 2018.
4. Perry Xiao, “Designing Embedded Systems and the Internet of Things (IoT) with the ARM Mbed”, John Wiley & Sons Ltd., 2018.

Reference Books:

3. Ronald Sass, Andrew G. Schmidt, "Embedded Systems Design with Platform FPGAs - Principles and Practices, Morgan Kaufmann Publishers, 2010.
4. Peter Marwedel, "Embedded System Design: Embedded System, Foundations of CyberPhysical Systems, and the internet of Things", 3rd edition, Springer International, 2018.

Gaps in the syllabus (to meet Industry/Profession requirements): N/A

POs met through Gaps in the Syllabus: PO8 will be met through report writing/presentation based assignment

Topics beyond syllabus/Advanced topics/Design:

1. Teaching through latest research paper

POs met through Topics beyond syllabus/Advanced topics/Design:

1. Teaching through paper

Course Outcome (CO) Attainment Assessment Tools & Evaluation Procedure

Direct Assessment

Assessment Tool	% Contribution during CO Assessment
Progressive Evaluation	60
End Sem Evaluation	40

Indirect Assessment

1. Students' Feedback on Course Outcome.

Mapping of Course Outcomes onto Program Outcomes

Course Outcome	Program Outcomes (POs)												Program Specific Outcomes (PSOs)		
	1	2	3	4	5	6	7	8	9	10	11	12	13	14	15
CO1	3	3	3	3	3	2	3	3	3	2	3	2	3	3	3
CO2	3	3	3	3	3	2	3	3	3	3	3	2	3	3	2
CO3	3	3	3	3	3	2	2	3	2	2	2	2	3	3	3
CO4	3	3	3	2	3	3	2	3	2	3	2	2	3	3	1
CO5	3	3	3	3	3	3	2	3	2	2	3	2	3	3	3

Correlation Levels 1, 2 or 3 as defined below:

1: Slight (Low) 2: Moderate (Medium) 3: Substantial (High)

Mapping Between COs and Course Delivery (CD) methods

Code	Course Delivery Methods	Course Outcome	Course Delivery Method Used
CD1	Lecture by use of Boards/LCD Projectors	CO1	CD1, CD7, CD8
CD2	Tutorials/Assignments	CO2	CD1 and CD9
CD3	Seminars	CO3	CD1,CD2,CD3
CD4	Mini Projects/Projects	CO4	CD1 and CD2
CD5	Laboratory Experiments/Teaching Aids	CO5	CD1 and CD2
CD6	Industrial/Guest Lectures		
CD7	Industrial Visits/In-plant Training		
CD8	Self- learning such as use of NPTEL Materials and Internets		
CD9	Simulation		

Course Information Sheet
Advanced Signal Processing Techniques

Course Code: EC363 R1

Course Title: Advanced Signal Processing Techniques

Pre-requisite(s): Signal Processing, Signal & System

Co-requisite(s):

Credits: L:3 T:0 P:0

Class schedule per week: 03

Class: B.Tech.

Semester / Level: VI

Branch: ECE

Name of Teacher:

Course Objectives:

This course aims to develop

1	To understand the concept of signals and systems and filters.
2	To impart knowledge on various transformation techniques.
3	To impart knowledge on multirate signal processing and its applications.
4	An understanding on optimum linear filters and power spectral estimation.
5	To understand the concept of adaptive filters and its applications.

Course Outcomes

On the completion of this course, the students will be able to:

CO1	Develop an understanding to concept of signal processing, systems and to design filters.
CO2	Have an ability to analyze and apply various single and multi-domain transformation techniques.
CO3	Have an ability to apply multirate signal processing on various engineering applications.
CO4	Develop an ability to apply use optimum linear filters and power spectral estimation.
CO5	Devise filtering solutions for optimising the cost function indicating error in estimation of parameters and apply the adaptive system.

Syllabus

Module 1: DSP Transforms: Fourier transform, Discrete cosine transform, Discrete Hartely transform, Wigner-Ville transform, Short time Fourier transform, Wavelet transform, Stockwell transform, Hilbert-Huang transform.

Module 2: Multi rate DSP, Decimators and Interpolators, Sampling rate conversion, multistage decimator & interpolator, poly phase filters, QMF, digital filter banks, Multi resolution signal analysis, wavelet decomposition, Applications in subband coding.

Module 3: Linear prediction and Optimum Linear Filters: Random signals and power spectra, Forward and backward Linear prediction, solutions of the normal equations, AR lattice and ARMA lattice-ladder filters, Wiener filters.

Module 4: Power spectrum estimation: Estimation of Spectra from Finite-Duration Observations of Signals. Nonparametric Methods for Power Spectrum Estimation, Parametric Methods for Power Spectrum Estimation, Minimum-Variance Spectral Estimation, Eigenanalysis Algorithms for Spectrum Estimation

Module 5: Adaptive systems: definitions and characteristics, Adaptive linear combiner: input signal and weight vector, the performance function, gradient and minimum mean square error, alternative expression of gradient, LMS, FXLMS, RLS, transform domain LMS algorithms.

Text Books:

1. J.G.Proakis and D.G.Manolakis“Digital signal processing: Principles, Algorithm and Applications”, 4th Edition, Prentice Hall, 2007.
2. N. J. Fliege, “Multirate Digital Signal Processing: Multirate Systems -Filter Banks – Wavelets”, 1st Edition, John Wiley and Sons Ltd, 1999.
3. B.Widrow and S. D. Sterns, Adaptive Signal Processing, Pearson Education, 2nd Indian reprint, 2002.
4. S. Haykin and T. Kailath, Adaptive Filter Theory, Pearson Education, 4th Edition, 2005.
5. C. K. Chui, An Introduction to Wavelets, Academic Press Inc., New York, 1992.

Reference Books:

1. Digital Signal Processing 3/E by S.K.Mitra TMH Edition.
2. Fundamentals of adaptive filtering, A. H. Sayed, Wiley, 2003.
3. Monson H. Hayes, Statistical Digital Signal Processing and Modelling, Wiley, 2002
4. Y.T. Chan, Wavelet Basics, Kluwer Publishers, Boston, 1993.

Gaps in the syllabus (to meet Industry/Profession requirements): Nil

POs met through Gaps in the Syllabus: N/A

Topics beyond syllabus/Advanced topics/Design:

Current technological developments advanced optimization techniques

Course Information Sheet
Advanced Signal Processing Techniques Lab

Course Code: EC364 R1

Course title: Advanced Digital Signal Processing Techniques Lab

Pre-requisite(s): Basic courses on Signal and System, DSP

Co-requisite(s):

Credits: L: 0 T: 0 P: 2 C:1 **Class**

schedule per week: 04 **Class:** M. Tech.

Semester / Level: I/05

Branch: ECE **Name of**

Teacher:

Course Objectives:

This course enables the students to:

A.	To understand the basics of signals and systems and its characteristics.
B.	To develop basic and advanced techniques in signal processing.
C.	To implement various basic DSP and Advanced DSP techniques in Hardware Platform (DSP Processor kit).
D.	Develop an understanding in analysing a signal and system behaviour in transform domain.
E.	To develop to apply advanced DSP techniques to various engineering applications.

Course Outcomes:

At the end of the course, a student should be able to:

1.	Demonstrate the theoretical knowledge acquired in Digital Signal Processing.
2.	To illustrate various techniques for signal modeling, representation, synthesis and analysis.
3.	Demonstrate applications of DSP to analyse signal in transformed domain.
4.	To apply various DSP algorithms in real life applications with hardware platform.
5.	Aspire for pursuing a carrier in signal processing, robotics and IOT, recognize the need to learn and adapt to the change in technology and play role of team leader or supporter of team.

SYLLABUS LIST OF

EXPERIMENTS:

1. Computation of the linear convolution and circular convolution of two finite-length sequences.
2. Obtain the Partial Fraction Expansion of the Z-Transform expression and to find its Inverse Z-Transforms. Test the stability of a Discrete Time System.
3. To write a program for finding the DFT and FFT of a Discrete time finite length sequence and implement it in TMS 320C6416 DSK Processor
4. Implement the Linear Convolution using TMS 320C6416 DSK Processor.
5. Development of the program for finding out DFT and FFT of a finite length sequence using TMS 320C6416 DSK Processor.

6. To write a program for designing a Digital Filter using TMS320C641 DSK Processor.
7. Implement LMS and RLS algorithm and perform the convergence analysis.
8. Representation of stationary and non-stationary signals using wavelet transformation.
9. Implementation of sub-band filtering approach using MATLAB.
10. Implement the system identification task in TMS 320C6713 DSK Processor.
11. Write a program for channel equalization and implement in TMS 320C6416 DSK Processor.
12. Write a program to implement the Image enhancement in Image.
13. Analyse the recording of an ECG Signals to measuring Heart Rate Variability.
14. Write an algorithm to perform the Noise cancellation using Adaptive filtering.

COURSE INFORMATION SHEET
Digital Systems Design with FPGAs

Course code: EC325 R1

Course title: Digital Systems Design with FPGAs

Pre-requisite(s): EC101 Basics of Electronics & Communication Engineering, EC201

Electronic Devices Co- requisite(s):

Credits: L: 3 T: 0 P: 0 C: 3

Class schedule per week: 03 Class:

B. Tech.

Semester / Level: VI/03

Branch: ECE

Name of Teacher:

Course Objectives

This course enables the students to:

1.	Understand Implementation strategies for digital ICs.
2.	Interpret timing Issues in digital circuits and apply the perceived knowledge.
3.	Appraise and analyse the arithmetic building blocks.
4.	Design and Evaluate the characteristics of memory and array structures.
5.	Validate and test manufactured circuits.

Course Outcomes

After the completion of this course, students will be able to:

CO1	Describe and illustrate with diagram the Implementation strategies for digital ICs.
CO2	Sketch and explain timing Issues in digital circuits.
CO3	Diagram and explain the arithmetic building blocks, illustrate their characteristics and analyse them.
CO4	Design and schematize the memory cell and array structures, assess their characteristics and summarize their features.
CO5	Schematize and write the principles of manufactured circuit test techniques. Integrate the techniques with circuit to be tested, validate and test the circuit.

SYLLABUS

MODULE	(NO. OF LECTURE HOURS)
<p>Module – I Implementation strategies for digital ICs: From Custom to Semicustom and Structured Array Design Approaches, Custom Circuit Design, Cell-Based Design Methodology, Array-Based Implementation Approaches: Pre-diffused (or MaskProgrammable) Arrays, Pre-wired Arrays: The write-once or fuse-based FPGA, The non-volatile FPGA, The volatile or RAM-Based FPGA, Implementation Platforms of the Future.</p>	8
<p>Module – II Timing Issues in digital circuits:Timing Classification of Digital Systems, Synchronous Design: Synchronous Timing Basics, Sources of Skew and Jitter, Clock-Distribution Techniques; Self-Timed Circuit Design: Self-Timed Adder Circuit, Completion-Signal Generation with an example of DCVSL, Self-Timed Signaling with an example of Muller C-element, Practical Examples of SelfTimed Logic such as Self-resetting 3-input OR; Synchronizers and Arbiters: Static Timing Analysis (STA), Design examples of clock and test bench using Verilog/SystemVerilog HDL.</p>	8
<p>Module – III Designing arithmetic building blocks: Full Adder Circuit Design Considerations, Multiplier Design Considerations; Power and Speed Tradeoff's in Datapath Structures: Design Time Power-Reduction Techniques, RunTime Power Management, Reducing the Power in Standby (or Sleep) Mode, Design examples of Datapath using Verilog/ SystemVerilog HDL.</p>	8
<p>Module – IV Designing memory and array structures: Memory classification, Memory Architectures and Building Blocks; The Memory Core: Read-Only Memories, Flash Memory, Static Random Access Memory (SRAM), Memory Peripheral Circuitry: The Address Decoders, Sense Amplifiers, Voltage References, Drivers/Buffers.</p>	8
<p>Module – V Validation and test of manufactured circuits: Boundary-Scan Design, Built-in Self-Test (BIST), Test-Pattern Generation, Fault Models: Stuck-At Faults, ShortCircuit and Open-Circuit Faults, Fault Coverage, Delay Fault Testing, Automatic Test-Pattern Generation (ATPG), FPGA-assisted testing.</p>	8

Textbooks:

1. J. Rabaey, A. Chandrakasan, B. Nikolic, "Digital Integrated Circuits: A Design Perspective", 2nd Edition, Prentice Hall, 2003.
2. Neil H. E. Weste and David Money Harris, CMOS VLSI Design – A Circuits and Systems Perspective, Addison Wesley, 4/e, 2011.

Reference books:

1. Samir Palnitkar, Verilog HDL: A guide to Digital Design and Synthesis, SunSoft Press, 1996.
2. Stuart Sutherland, Simon Davidmann, Peter Flake, SystemVerilog Design - A Guide to Using SystemVerilog for Hardware Design and Modeling, 2/e, Springer, 2006.

Gaps in the syllabus (to meet Industry/Profession requirements):

1. Hands-on-practical for CMOS IC (Integrated Circuit) fabrication.

COURSE INFORMATION SHEET
Digital Systems Design with FPGAs Lab

Course code: EC326 R1

Course title: Digital Systems Design with FPGAs Lab

Pre-requisite(s): EC101 Basics of Electronics & Communication Engineering, EC201 Electronic Devices

Co- requisite(s): EC361 Digital Systems Design with FPGAs

Credits: L: 0 T: 0 P: 2 C: 1.0

Class schedule per week: 03 Class:

B. Tech.

Semester / Level: VI/03

Branch: ECE Name

of Teacher:

This course enables the students to:

A.	Understand the modelling styles of HDLs such as VHDL, Verilog and SystemVerilog for designing/developing digital circuits.
B.	Apply their understanding to design/develop given digital circuits using various modelling styles of VHDL/Verilog/SystemVerilog.
C.	Analyse and explain the outputs displayed on the prototyping board.
D.	Appraise the simulated/compiled/synthesized/downloaded CPLD/FPGA designs and evaluate the results.
E.	Develop CPLD/FPGA designs and create necessary configuration bitstream files and download them on the prototyping kit.

Course Outcomes

After the completion of this course, students will be able to:

CO1	Outline models of digital circuits and translate the same into VHDL/Verilog/SystemVerilog program. Simulate, compile, synthesize, and download CPLD designs onto the prototyping kit and demonstrate/show the results displayed on the kit and explain the same.
CO2	Write VHDL/Verilog/System Verilog model and develop given digital circuits. Simulate and synthesize the CPLD design. Use Spartan-2 CPLD Trainer Kit and download the design onto it. Demonstrate and interpret the results displayed on the kit.
CO3	Outline VHDL/Verilog/SystemVerilog model and given design digital circuits. Simulate and compile/synthesize the CPLD design, download the same onto the prototyping kit (Spartan-2 CPLD Trainer Kit). Test and analyse the outputs displayed on the kit
CO4	Write VHDL/Verilog/SystemVerilog model of given digital circuit. Simulate and compile/synthesize the FPGA design and find errors, if any. Create the FPGA configuration bitstream file, download the same onto the prototyping kit (Spartan-3E FPGA Starter Kit) and test its operation and evaluate outputs displayed on the kit.

CO5	Develop VHDL/Verilog/SystemVerilog model and design given digital circuits. Simulate and compile/synthesize the FPGA design, create the FPGA configuration bitstream file, download the same onto the prototyping kit (Spartan-3E FPGA Starter Kit), test and validate its operation.
-----	---

SYLLABUS

Lab is the application of the theory (i.e., hands-on experiments related to the course contents). Therefore, **EC361 Digital Systems Design with FPGAs** is the syllabus for the **EC362 Digital Systems Design with FPGAs Lab**. Following experiments are the guidelines for the students. However, the questions for exams are not limited to this experiment list.

List of Compulsory experiments:

- Outline a model of clock generator and test bench for simulating a digital circuit and translate the same into VHDL/Verilog/SystemVerilog RTL codes. Simulate and synthesize the CPLD design using the Xilinx development software (**Xilinx ISE 8.1i.**) and find errors, if any. Create the CPLD configuration bitstream file (*.jed), use **Spartan-2 CPLD Trainer Kit** and download CPLD design (using the iMPACT programming software and the JTAG cable) onto it, demonstrate/show the results displayed on the kit and explain the same.
- Write VHDL/Verilog/SystemVerilog RTL codes and develop a sign-magnitude adder. Simulate and synthesize the CPLD design using the Xilinx development software (**Xilinx ISE 8.1i.**) and find errors, if any. Create the CPLD configuration bitstream file (*.jed), use **Spartan-2 CPLD Trainer Kit** and download CPLD design (using the iMPACT programming software and the JTAG cable) onto it. Observe/examine the results for their correctness.
- Outline a switch-level Verilog/SystemVerilog model and write RTL codes for the circuit shown below. Experiment with the prototyping kit (**Spartan-3E FPGA Starter Kit**), test and analyse its operation.

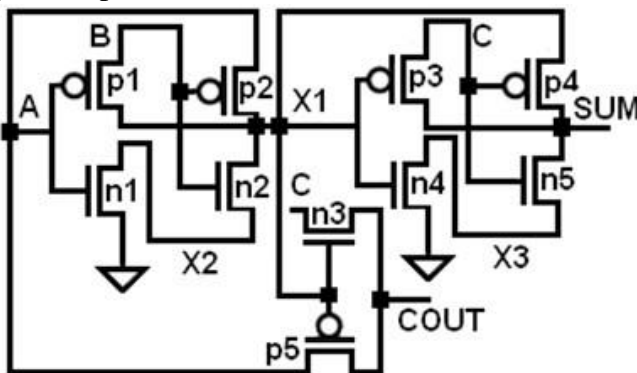

- Outline a VHDL/Verilog/SystemVerilog model and design a stopwatch. Simulate and compile/synthesize the FPGA design using the Xilinx development software (**Xilinx ISE 14.1i.**) and find errors, if any. Create the FPGA configuration bitstream file (*.bit), download FPGA design (using the iMPACT programming software and the USB cable) onto the prototyping kit (use **Spartan-3E FPGA Starter Kit**), test and evaluate its operation.
- Develop a VHDL/Verilog/SystemVerilog model and design a digital multiplier. Simulate and compile/synthesize the FPGA design using the Xilinx development software, create the FPGA configuration bitstream file (*.bit), download FPGA design (using the iMPACT programming

software and the USB cable) onto the prototyping kit (use **Spartan-3E FPGA Starter Kit**), test and validate its operation.

10. Develop a VHDL/Verilog/SystemVerilog model and design a traffic signal controller. Simulate and compile/synthesize the FPGA design using the Xilinx development software, create the FPGA configuration bitstream file (*.bit), download FPGA design (using the iMPACT programming software and the USB cable) onto the prototyping kit (use **Spartan3E FPGA Starter Kit**), test and validate its operation.
11. Design 2-input XOR gate using complex gate and use the same to design a 1-bit full adder within the given specification to achieve propagation delay (t_p) of OUTPUT CARRY no longer than 100 ns and average power consumption (P_{avg}) not higher than 100 μ W. Simulate the designs, test and validate your anticipation using Cadence EDA tool. Load the input and output of the designed full adder with inverters to obtain realistic input and output. Simulate and report the propagation delay (t_p) and power consumption (P_{avg}) of your design.
12. Develop a 4-bit full adder utilizing the previously designed 1-bit full adder within the given specification to achieve propagation delay (t_p) of the FINAL CARRY no longer than 1 μ s and average power consumption (P_{avg}) not higher than 1 mW. Simulate the designs using Cadence EDA tool, test and validate your anticipation. Load the input and output of the designed full adder with 1-bit full adder to obtain realistic input and output. Simulate and report the propagation delay (t_p) and power consumption (P_{avg}) of your design.
13. Design a positive-edge-triggered D flip-flop with setup time and hold time no longer than 10 ns and 15 ns respectively. Simulate using Cadence EDA tool and find errors, if any. Test its functionality, tabulate the obtained results for setup time and hold time and compare the same with the given specifications.
14. Develop a 4-bit register based on the previously designed positive-edge-triggered D flip-flop. Simulate using Cadence EDA tool and find errors, if any. Test its functionality.
15. Design a JK flip-flop with setup time and hold time no longer than 20 ns and 25 ns respectively. Simulate using Cadence EDA tool and find errors, if any. Test its functionality, tabulate the obtained results for setup time and hold time and compare the same with the given specifications.
16. Develop a 4-bit presettable counter based on the previously designed a JK flip-flop. Simulate using Cadence EDA tool and find errors, if any. Test its functionality.

List of optional experiments:

17. Develop a VHDL/Verilog/SystemVerilog model and design a floating-point adder. Simulate and compile/synthesize the FPGA design using the Xilinx development software, create the FPGA configuration bitstream file (*.bit), download FPGA design (using the iMPACT programming software and the USB cable) onto the prototyping kit (use **Spartan-3E FPGA Starter Kit**), test and validate its operation.
18. Develop a VHDL/Verilog/SystemVerilog model and design a FIFO buffer. Simulate and compile/synthesize the FPGA design using the Xilinx development software, create the FPGA configuration bitstream file (*.bit), download FPGA design (using the iMPACT programming software and the USB cable) onto the prototyping kit (use **Spartan-3E FPGA Starter Kit**), test and validate its operation.

19. Develop a VHDL/Verilog/SystemVerilog model and design a divider. Simulate and compile/synthesize the FPGA design using the Xilinx development software, create the FPGA configuration bitstream file (*.bit), download FPGA design (using the iMPACT programming software and the USB cable) onto the prototyping kit (use **Spartan-3E FPGA Starter Kit**), test and validate its operation.
20. Develop a VHDL/Verilog/SystemVerilog model and design a BINARY-TO-BCD conversion circuit. Simulate and compile/synthesize the FPGA design using the Xilinx development software, create the FPGA configuration bitstream file (*.bit), download FPGA design (using the iMPACT programming software and the USB cable) onto the prototyping kit (use **Spartan3E FPGA Starter Kit**), test and validate its operation.
21. Write a VHDL/Verilog/SystemVerilog model and develop a 1:4-bit demultiplexer. Simulate and synthesize the CPLD design using the Xilinx development software (**Xilinx ISE 8.1i.**) and find errors, if any. Create the CPLD configuration bitstream file (*.jed), use **Spartan-2 CPLD Trainer Kit** and download CPLD design (using the iMPACT programming software and the JTAG cable) onto it, demonstrate and interpret the results displayed on the kit.
22. Write a VHDL/Verilog/SystemVerilog model and develop a 4-bit magnitude comparator. Simulate and synthesize the CPLD design using the Xilinx development software (**Xilinx ISE 8.1i.**) and find errors, if any. Create the CPLD configuration bitstream file (*.jed), use **Spartan-2 CPLD Trainer Kit** and download CPLD design (using the iMPACT programming software and the JTAG cable) onto it, demonstrate and interpret the results displayed on the kit.
23. Outline a VHDL/Verilog/SystemVerilog model and design a seven-segment display decoder. Simulate and compile/synthesize the CPLD design using the Xilinx development software (**Xilinx ISE 8.1i.**) and find errors, if any. Create the CPLD configuration bitstream file (*.jed), download CPLD design (using the iMPACT programming software and the JTAG cable) onto the prototyping kit (use **Spartan-2 CPLD Trainer Kit**), test and analyse the outputs displayed on the kit.
24. Develop a VHDL/Verilog/SystemVerilog model and design a simple processor that performs basic operations such as ADD, SUM, MUL and DIV using 8-bit operands. Simulate and compile/synthesize the FPGA design using the Xilinx development software, create the FPGA configuration bitstream file (*.bit), download FPGA design (using the iMPACT programming software and the USB cable) onto the prototyping kit (use **Spartan-3E FPGA Starter Kit**), test and validate its operation.
25. Outline a VHDL/Verilog/SystemVerilog model and design a 16:4-bit encoder. Synthesize the circuit, download the configuration bitstream file onto the prototyping kit (use **Spartan-2 CPLD Trainer Kit**) and verify its operation. Simulate and compile/synthesize the CPLD design using the Xilinx development software (**Xilinx ISE 8.1i.**) and find errors, if any. Create the CPLD configuration bitstream file (*.jed), download CPLD design (using the iMPACT programming software and the JTAG cable) onto the prototyping kit (use **Spartan-2 CPLD Trainer Kit**), test and analyse outputs displayed on the kit.
26. Outline a VHDL/Verilog/SystemVerilog model and design a modulo-N binary up-counter with synchronous Clear control signal. Simulate and compile/synthesize the CPLD design using the Xilinx development software (**Xilinx ISE 8.1i.**) and find errors, if any. Create the CPLD configuration bitstream file (*.jed), download CPLD design (using the iMPACT programming software and the JTAG cable) onto the prototyping kit (use **Spartan-2 CPLD Trainer Kit**), test and analyse outputs displayed on the kit.

27. Write a VHDL/Verilog/SystemVerilog model of 2-by-2 register. Simulate and compile/synthesize the FPGA design using the Xilinx development software (**Xilinx ISE 14.1i.**) and find errors, if any. Create the FPGA configuration bitstream file (*.bit), download FPGA design (using the iMPACT programming software and the USB cable) onto the prototyping kit (use **Spartan-3E FPGA Starter Kit**) and test its operation and evaluate output displayed on the kit.
28. Write an 8x8 RAM VHDL/Verilog/SystemVerilog model. Simulate and compile/synthesize the FPGA design using the Xilinx development software (**Xilinx ISE 14.1i.**) and find errors, if any. Create the FPGA configuration bitstream file (*.bit), download FPGA design (using the iMPACT programming software and the USB cable) onto the prototyping kit (use **Spartan3E FPGA Starter Kit**) and test its operation and evaluate output displayed on the kit.

Textbooks:

1. J. Rabaey, A. Chandrakasan, B. Nikolic, “Digital Integrated Circuits: A Design Perspective”, 2nd ed., Prentice Hall, 2003.
2. Neil H. E. Weste, David Money Harris, “CMOS VLSI Design – A Circuits and Systems Perspective,” 4th ed., Addison Wesley, 2011.
3. Neil H. E. Weste, David Money Harris, “CMOS VLSI Design – A Circuits and Systems Perspective,” 3rd ed., Pearson Education, 2006.

Reference books:

1. Samir Palnitkar, “Verilog HDL: A guide to Digital Design and Synthesis,” SunSoft Press, 1996.
2. Stuart Sutherland, Simon Davidmann, Peter Flake, “SystemVerilog Design - A Guide to Using SystemVerilog for Hardware Design and Modeling,” 2nd ed., Springer, 2006.

COURSE INFORMATION SHEET
Microelectronic Devices and Circuits

Course code: EC365 R1

Course title: Microelectronic Devices and Circuits

Pre-requisite(s): EC101 Basics of Electronics & Communication Engineering, EC201 Electronic Devices Co- requisite(s):

Credits: L: 3 T: 0 P: 0 C: 3

Class schedule per week: 03 Class: B.
Tech.

Semester / Level: V/03

Branch: ECE Name

of Teacher:

Course Objectives

This course enables the students to:

6.	Understand the Physics of Modern Devices.
7.	Grasp the characteristics modern MOS Devices and apply the obtained knowledge.
8.	Appraise and analyse the CMOS Performance Factors.
9.	Evaluate the characteristics of Current Mirrors, Single- and -two Stage OTA.
10.	Comprehend the manufacturing principles of CMOS integrated circuits and create/develop their structures.

Course Outcomes

After the completion of this course, a student will be able to:

CO1	Describe and illustrate the Physics of Modern Devices.
CO2	Sketch and explain the modern MOS Devices.
CO3	Illustrate with the sketch the CMOS Performance Factors, diagram their characteristics and analyse them.
CO4	Design and schematize the Current Mirror, Single- and -two Stage OTA; assess their characteristics and summarize their features.
CO5	Appraise the Manufacturing steps and Layout of CMOS Integrated Circuits and create/develop/design their structures.

SYLLABUS

MODULE	(NO. OF LECTURE HOURS)
<p>Module – I Basic Device Physics: Modern CMOS Transistors: CMOS processes, CMOS process enhancements, Metal-Silicon Contacts, High-Field Effects: Impact Ionization and Avalanche Breakdown, Band-to-Band Tunneling, Tunneling into and through Silicon Dioxide, Injection of Hot Carriers from Silicon into Silicon Dioxide, High-Field Effects in Gated Diodes, Dielectric Breakdown</p>	8
<p>Module – II MOS Devices: Long-Channel MOSFETs, Short-Channel MOSFETs, MOSFET Scaling, Threshold Voltage: Various Definitions of Threshold Voltage, Channel Profile Design, Nonuniform Doping, Quantum Effect on Threshold Voltage, Discrete Dopant Effects on Threshold Voltage. MOSFET Channel Length: Various Definitions of Channel Length, Extraction of the Effective Channel Length.</p>	8
<p>Module – III CMOS Performance Factors: Basic CMOS Circuit Elements, Parasitic Elements, Sensitivity of CMOS Delay to Device Parameters, Performance Factors of Advanced CMOS Devices: MOSFETs in RF Circuits, Effect of Transport Parameters on CMOS Performance, Low-Temperature CMOS.</p>	8
<p>Module – IV Current Mirrors, Single- and -two Stage OTA: Current Mirror, MOS Differential Pair: Qualitative Analysis, Large-Signal Analysis, Small-Signal Analysis; Frequency Response of Differential Pairs; Design of Current-sink CMOS inverting Amplifier, General Characteristics of the ideal CMOS OTA, Division of a two-stage uncompensated CMOS OTA into voltage-to-current and current-to-voltage stages, Functions of different stages, two-stage CMOS OTA.</p>	8
<p>Module – V Manufacturing steps and Layout of CMOS Integrated Circuits: CMOS IC fabrication Steps: Silicon Wafer, Diffusion, ion-implantation, annealing, etching, patterning or lithography, oxidation, sputtering, deposition, metallization, planarization; Layout: Design Rules, Stick Diagram, Layouts of Universal Gates & complex logic gates; Variability and Mismatch; Analog Layout Considerations: Analog design issues, common-centroid layout, capacitor & resistor layout and matching.</p>	8

Textbooks:

1. Neil H. E. Weste and Kamran Eshraghian, "Principles of CMOS VLSI Design: A Systems Perspective", 2nd ed., Addison-Wesley, 1993.
2. Y. Taur and T. H. Ning, "Fundamentals of Modern VLSI Devices," Cambridge University Press, NY, USA, 2/e, 2009.
3. Behzad Razavi, Fundamentals of Microelectronics, Wiley, 2009.
4. Neil H. E. Weste and David Harris, "CMOS VLSI Design: A Circuits and Systems Perspective", 4th International Edition, Pearson Education, Inc., 2011.

Reference books:

1. Tony Chan Carusone, David A. Johns and Kenneth W. Martin, Analogue Integrated Circuit Design, 2/e, John Wiley & Sons, 2012.
2. Phillip E. Allen & Douglas R. Holberg, CMOS Analog Circuit Design, 3/e, Oxford University Press, 2012.

COURSE INFORMATION SHEET
Microelectronic Devices and Circuits Lab.

Course code: EC366

Course title: Microelectronic Devices and Circuits Lab

Pre-requisite(s): EC101 Basics of Electronics & Communication Engineering, EC201 Electronic Devices

Co- requisite(s): EC321 Microelectronic Devices and Circuits

Credits: L: 0 T: 0 P: 2 C: 1

Class schedule per week: 02

Class: B. Tech.

Semester / Level: VI/03

Branch: ECE

Name of Teacher:

Course Objectives

Course Objectives

This course enables the students to:

A.	Understand the usages of subcircuit and perform corner analyses.
B.	Apply their understanding to estimate threshold voltage and extract effective gate capacitance, effective parasitic capacitance and effective series resistance.
C.	Analyze a circuit for logical effort characterization and analyse a current-sink inverting amplifier.
D.	Apply a current steering circuit for its various applications.
E.	Create layouts of universal gates, complex logic gates, and 6T SRAM cell.

Course Outcomes

After the completion of this course, students will be able to:

CO1	Use subcircuit for designing FO4 and measure the t_{pdr} and t_{pdf} and propagation delay (t_{pd}). Perform corner analyses unloaded inverter in the TT, FF, SS, FS and SF corners to verify operation across variations in device characteristics and environment.
CO2	Estimate threshold voltage of MOSFETs using constant current and linear extrapolation methods. Extract effective gate capacitance, effective parasitic capacitance and effective series resistance of MOSFET for delay estimation.
CO3	Design and analyze a circuit for logical effort characterization of inverter and 2-input NAND gate. Design and analyze current-sink CMOS inverting amplifier.
CO4	Design and analyze a current steering circuit for its various applications.
CO5	Design and analyse layouts of universal gates, complex logic gates, and 6T SRAM cell.

SYLLABUS

Lab is the application of the theory (i.e., hands-on experiments related to the course contents). Therefore, **EC321 Microelectronic Devices and Circuits** is the syllabus for the **EC322 Microelectronic Devices and Circuits Lab**. Following experiments are the guidelines for the students. However, the questions for exams are not limited to this experiment list.

List of Compulsory experiments:

1. Design a fanout-of-4 inverter using subcircuit and measure the t_{pdr} and t_{pdf} and propagation delay (t_{pd}).
2. Perform corner analyses on unloaded inverter in the TT, FF, SS, FS and SF corners to verify operation across variations in device characteristics and environment using SPICE/Cadence Virtuoso ADE.
3. Estimate threshold voltage of nMOS and pMOS transistors using constant current threshold voltage extraction method and linear extrapolation (or maximum-gm) method using SPICE/Cadence Virtuoso ADE.
4. Design a circuit for extracting effective parasitic capacitance of single nMOS and pMOS transistors for delay estimation using SPICE/Cadence Virtuoso ADE.
5. Design a circuit for extracting effective series resistance of single nMOS and pMOS transistors for delay estimation using SPICE/Cadence Virtuoso ADE.
6. Design a circuit for logical effort characterization of inverter and 2-input NAND gate using SPICE/Cadence Virtuoso ADE.
7. Design of current-sink CMOS inverting amplifier using SPICE/Cadence Virtuoso ADE.
8. Design a current amplifier and estimate its current gain. Also design a current mirror circuit for its application in 2-stage operational-transconductance amplifier (OTA) using SPICE/Cadence Virtuoso ADE.
9. Design a current steering circuit for sinking current from source-follower amplifier and sourcing current to a common-source amplifier using SPICE/Cadence Virtuoso ADE.
10. Design layouts of universal gates & complex logic gates using Micro wind/ Cadence Virtuoso ADE.
11. Design layout of 6T SRAM cell using Micro wind/ Cadence Virtuoso ADE.
12. Design 6T SRAM cell using 3D Visual TCAD/Silvaco TCAD/Synopsis TCAD.

List of optional experiments:

13. Perform optimization simulation on FO4 inverter to achieve nearly equal rise/fall times using SPICE/Cadence Virtuoso ADE.
14. Design a circuit for extracting effective gate capacitance of single nMOS and pMOS transistors for delay estimation using SPICE/Cadence Virtuoso ADE.
15. Show the breakdown characteristics of long-channel and short-channel nMOSFET at high drain voltages using SPICE/Cadence Virtuoso ADE.
16. Show the I_{OFF} - I_{ON} plot of long-channel and short-channel nMOSFET using SPICE/Cadence Virtuoso ADE.

17. Obtain the Threshold voltage versus channel length of short-channel nMOSFET using SPICE/Cadence Virtuoso ADE.
18. Obtain the Threshold voltage versus V_{DS} of short-channel nMOSFET using SPICE/Cadence Virtuoso ADE.
19. Design layout of 8T SRAM cell using Micro wind/ Cadence Virtuoso ADE.
20. Design a HEMT using 3D Visual TCAD/Silvaco TCAD/Synopsis TCAD.
21. Design a TFET using 3D Visual TCAD/Silvaco TCAD/Synopsis TCAD.
22. Design FinFET using 3D Visual TCAD/Silvaco TCAD/Synopsis TCAD.
23. Design nanowire FET using 3D Visual TCAD/Silvaco TCAD/Synopsis TCAD.
24. Design inverter using 3D Visual TCAD/Silvaco TCAD/Synopsis TCAD.
25. Design Low Noise Amplifier and estimate its design metrics.
26. Design Voltage-Controlled Oscillator and estimate its design metrics.
27. Design a Mixer circuit and estimate its design metrics.
28. Write a VHDL/Verilog/SystemVerilog model of 2-by-2 register. Simulate and compile/synthesize the FPGA design using the Xilinx development software (**Xilinx ISE 14.1i.**) and find errors, if any. Create the FPGA configuration bitstream file (*.bit), download FPGA design (using the iMPACT programming software and the USB cable) onto the prototyping kit (use **Spartan-3E FPGA Starter Kit**) and test its operation and evaluate output displayed on the kit.
29. Write an 8x8 RAM VHDL/Verilog/SystemVerilog model. Simulate and compile/synthesize the FPGA design using the Xilinx development software (**Xilinx ISE 14.1i.**) and find errors, if any. Create the FPGA configuration bitstream file (*.bit), download FPGA design (using the iMPACT programming software and the USB cable) onto the prototyping kit (use **Spartan-3E FPGA Starter Kit**) and test its operation and evaluate output displayed on the kit.

Textbooks:

1. Y. Taur and T. H. Ning, "Fundamentals of Modern VLSI Devices," Cambridge University Press, NY, USA, 2/e, 2009.
2. Neil H. E. Weste, David Money Harris, "CMOS VLSI Design – A Circuits and Systems Perspective," 4th ed., Addison Wesley, 2011.

Reference books:

1. Samir Palnitkar, "Verilog HDL: A guide to Digital Design and Synthesis," SunSoft Press, 1996.
2. Neil H. E. Weste, David Money Harris, "CMOS VLSI Design – A Circuits and Systems Perspective," 3rd ed., Pearson Education, 2006.
3. J. Rabaey, A. Chandrakasan, B. Nikolic, "Digital Integrated Circuits: A Design Perspective", 2nd ed., Prentice Hall, 2003.

COURSE INFORMATION SHEET
Antenna and Wave Propagation

Course code: EC327 R1

Course title: Antenna and Wave Propagation

Pre-requisite(s): Knowledge of Electromagnetic theory, Basic understanding of Network Theorem

Co- requisite(s): Electromagnetic Theory

Credits: L:3 T :0 P :0 C:3

Class schedule per week: 03/week

Class: B. Tech

Semester / Level: Fifth

Branch: ECE

Name of Teacher:

Course Objectives

This course enables the students:

1.	To impart knowledge on the fundamental antenna parameters .
2.	To develop the concept of mechanism of radio wave propagation and applications.
3.	To Analyze the concepts associated with operating principles of antenna theory, antenna performance, operation ,classification and applications.
4.	To explain the concept and basic principles associated with the implementation of antenna arrays.
5.	To Apply the Antenna measurement techniques using microwave equipment setup.

Course Outcomes

After the completion of this course, students will be:

CO1	Understand the basic radiation mechanism and antenna parameters.
CO2	Design and characterize the various antenna arrays
CO3	Analyze the wire antennas and aperture antennas.
CO4	Apply the knowledge on the measurements of Antenna parameters.
CO5	Understand the concept of the wave propagation in free space.

SYLLABUS

MODULE	(NO. OF LECTURE HOURS)
<p>Module – I Antenna Fundamentals: Radiation mechanism - single wire, two wire, dipole and current distribution on thin wire, Radiated field components - Hertzian dipole, Half wave Dipole and Monopole Antenna. Antenna Parameters: Radiation Pattern, Beam Width, Radiation Power Density, Directivity and Gain, Bandwidth, Polarization, Input Impedance, Efficiency, Antenna Effective Length and Area, Antenna Temperature, Reciprocity Principle. Problem solving .</p>	10
<p>Module – II Antenna Arrays: Linear Array - Two element array, N-element linear array- Broadside array, End fire array- Directivity, Pattern Multiplication, Non-uniform excitation- Binomial Array, Problem solving</p>	9
<p>Module – III Special Antennas: Practical antennas VLF, LF, MF transmitting antennas ,resonant antennas & non resonant antennas , Wire Antennas- Small Loop Antenna, V-Antenna, Rhombic antenna, Helical antenna and Yagi-Uda antenna, Frequency Independent Antenna - Spiral and Log periodic antenna, Aperture antennas - Horn antenna, Parabolic Reflector antenna, Microstrip antenna.</p>	8
<p>Module – IV Antenna Measurements: Measurement of antenna impedance , Pattern measurements, Measurement of Antenna Gain, Beam width , Radiation resistance , Antenna efficiency , Directivity -Polarization.</p>	7
<p>Module – V Propagation of radio waves: Mode of propagation Ground wave propagation, sky wave propagation Space wave propagation, atmospheric effects, structure of atmosphere General picture of ionosphere, and its effect on radio waves. skip distance, MUF, ionospheric propagation, Fading, Problem solving</p>	6

Text Books:

1. E.C. Jordan & K.G. Balmain, Electromagnetic waves & Radiating Systems, PHI, 2007
2. .D. Kraus, R.J. Marhefka and Ahmad S Khan, Antennas and Wave Propagation, 4th Edition, Mc Graw Hill, 2010

Reference Book:

1. Antennas and Wave propagation by A.R.Harish, M.Sachidananda, Oxford University press ,1st edition 2007,ISBN-13:978-0-19-568666-1,ISBN -10: 0-19-568666-7

COURSE INFORMATION SHEET
Antenna and Wave Propagation Lab

Course code: EC328

Course title: Antenna and Wave Propagation Lab

Pre-requisite(s): EC325 Antenna and Wave Propagation

Co- requisite(s): EC257 Electromagnetic Fields and Waves

Credits: L: 0 T: 0 P: 2 C: 1 1.5 Class periods per week: 03 Class: B.
Tech.

Semester / Level: VI/

Branch: ECE Name of

Teacher:

Course Objectives

This course enables the students to:

1.	Develop Knowledge of Electromagnetics wave propagation in different medium
2.	Identify, formulate, review and analyze engineering problems reaching substantiated conclusions.
3.	Use research-based knowledge and research methods including design of experiments, analysis and interpretation of data in the field of electronics and communication.
4.	Design system components or processes as per need and specification.
5.	Select, and apply appropriate techniques, modern engineering tools, skills and equipment necessary for engineering practices.

Course Outcomes

After the completion of this course, students will be able to:

CO1	Understand the importance of EM waves in Antenna.
CO2	Identify and measure the basic antenna parameters.
CO3	Identify and understand different types of antennas, radiation pattern.
CO4	Analyze matching and feeding networks for antennas.
CO5	Identify the characteristics of radio wave propagation.

SYLLABUS

Lab is the application of the theory (i.e., hands-on experiments related to the course contents). Therefore, EC325 **Antenna and Wave Propagation** is the syllabus for the **Antenna and Wave Propagation Lab**. Following experiments are the guidelines for the students. However, the questions for exams are not limited to this experiment list.

List of Compulsory experiments

1. To Design a Dipole antenna excited by a plane-wave directed along the positive x-axis and having a z-polarization Using MATLAB
2. To Design a Helical Antenna at 1.8 GHz Using MATLAB
3. To Measure the signal received by the E-field probe as a measure for the transmitted microwave power behind a dry and a moistened mat.
4. To Generate a standing Microwave through reflection from metal piece and measure its field distribution.
5. To Measure Gain, Radiation Pattern and 3dB beamwidth of an Antenna

List of Research Experiment

1. To Design a Bluetooth Antenna Using Ie3D
2. To Design a UWB antenna Using Ie3D
3. To Design a Frequency Independent antenna Using Ie3D
4. To Design a Circularly Polarized antenna Using Ie3D
5. To Design a Dual band antenna Using Ie3D
6. To Design an MIMO antenna Using Ie3D
7. To Design an adaptive antenna using MATLAB

Note: Students need to perform at least 3 Research Experiment along with 5 Compulsory Experiments.

Books recommended:

Textbooks::

1. J.D. Krauss, "Antennas for all applications", Fourth Edition, MH publication, 2010
2. C. Balanis, "Antenna Theory: Analysis and design", Third Edition, Wiley India, 2005.

COURSE INFORMATION SHEET
Wireless Networks

Course Code: EC367

Course Title: Wireless Networks

Pre-requisite(s): Basic Sciences Co- requisite(s):

Credits: L: 3 T: 0 P: 0 C:3

Class schedule per week: 03 Class:

B. Tech.

Semester / Level: Sixth/Three

**Branch: Electronics & Communication Engineering Name
of Teacher:**

Course Objectives

This course envisions to impart to students to:

16.	Explain basics of wireless networks system
17.	Explain network protocols used for WPAN, WLAN and WWAN.
18.	Explain Transmission control protocol
19.	Explain IPv4 and IPV6 addressing system
20.	An ability to explain the functioning, protocols, capabilities and application of various wireless communication networks.

Course Outcomes

After the completion of this course, students will be able to:

CO1	Demonstrate an understanding on basics of Wireless network system
CO2	Demonstrate an ability to identify the protocol for network environment based on geographical condition, dimension and resource condition
CO3	Demonstrate an understanding on IP addressing protocol
CO4	Demonstrate an understanding on basics of Wireless network system
CO5	Explain the functioning, protocols, capabilities and application of various wireless communication networks.

SYLLABUS

MODULE	(NO. OF LECTURE HOURS)
<p>Module – I</p> <p>Ad-hoc wireless networks : MANET and WSN, security in wireless networks, energy constrained networks, adhoc versus Infrastructure based wireless networks</p>	9
<p>Module – II</p> <p>Wireless personal area networks (bluetooth, network connection establishment in bluetooth, bluetooth protocol stack, bluetooth link type, bluetooth security. ZigBee: components & network Topologies. ultra wideband communication</p>	9
<p>Module – III</p> <p>Wireless local area and metropolitan area networks: WLAN Technology, network architecture, protocol architecture, physical layer, data link layer, medium access methods, security in 802.11 systems, WLAN standards. Wireless metropolitan area networks (WiMAX).</p>	8
<p>Module – IV</p> <p>Wireless wide area networks: GSM, GPRS, 3G wireless systems, evolution of cdma2000, differences between cdma2000 & WCDMA. HSPA and LTE.</p>	8
<p>Module – V</p> <p>Wireless network protocols: mobile network layer protocol (mobile IP, Ipv4 vs. IPv6, IPv6, IPv6 transition mechanism, dynamic host configuration protocol), mobile transport layer protocol (traditional TCP, classical TCP improvements), agent discovery, agent advertisement, registration, authentication, route optimisation, mobility support for IPV6.</p>	7

Text Books:

1. J. Schiller, “Mobile Communication” 2/e, Pearson Education, 2012.
2. Vijay K Garg, “Wireless Communications and Networks”, Morgan Kaufmann Publishers an Imprint of Elsevier, USA 2009 (Indian reprint) **Reference**

Books:

1. Behrouz A. Forouzan, “Data Communications and Networking”, McGraw-Hill, 2007
2. Sanjay Kumar, “Wireless Communication the Fundamental and Advanced Concepts” River Publishers, Denmark, 2015 (Indian reprint).

COURSE INFORMATION SHEET

Wireless Networking Lab

Course code: EC368

Course title: Wireless Networking Lab

Pre-requisite(s): Fundamental Knowledge of Communication System, basic understanding of communication process and communication media **Co- requisite(s):**

Credits: L: 0 T: 0 P: 2 C: 1

Class schedule per week: 03 **Class:** B. Tech.

Semester / Level: Sixth/Three

Branch: Electronics & Communication Engineering

Name of Teacher: ALL

Course Objectives:

This course enables the students:

1	To develop an ability to design various kind of wired/wireless networks using network simulator.
2	To evaluate and compare the performance of several network protocols (AODV, DYMO etc).
3	To design and interpret wireless sensor networks and standards
4	To design and examine the hardware setup for wireless Wide Area network
5	To design and examine the hardware setup for wireless sensor network

Course Outcomes:

After the completion of this course, students will be able to:

CO1	Have an ability to design and evaluate various kind of wired/wireless networks.
CO2	Be able to analyze and compare the performance of various routing protocols (like AODV, DYMO etc) for wireless adhoc network as well as for infrastructure based wireless network.
CO3	Have an ability to design and interpret wireless networks and standards (WLAN, Bluetooth etc) through simulation software as well as evaluate the impact of various system parameters on wireless standards.
CO4	Have an ability to design and analyze the hardware setup for wireless Wide Area network
CO5	Have an ability to design and analyze the hardware setup for

Syllabus

List of Compulsory experiments:

1. Name of the Experiment: Set up link to analyze flow of operation (packets)

AIM-1: Study and demonstrate the flow of operation (packets) in QualNet Network Simulator GUI.

2. Name of the Experiment: Set up link to analyze Ad hoc mode scenario

AIM-1: Design and evaluate an Ad hoc mode scenario using QualNet Network Simulator.

3. Name of the Experiment: Set up link to analyze infrastructure mode scenario

AIM-1: To configure and evaluate an infrastructure mode scenario using QualNet Simulator GUI.

4.Name of the Experiment: Set up link to measure effect of mobility in an Ad hoc mode scenario

AIM-1: Configure and estimate the effect of mobility to the data transferred in an Ad hoc mode scenario.

5.Name of the Experiment: : Set up link to measure effect of mobility in an infrastructure mode scenario

AIM-1: Configure and estimate the effect of mobility to the data transferred in an infrastructure mode.

6.Name of the Experiment: Compare AODV and DYMO

AIM-1: Compare two routing protocols (AODV and DYMO) in ad hoc mode scenario.

7.Name of the Experiment: Configure VOIP Application Layer Protocol

AIM-1: **Configure** VOIP Application layer protocol based on H.323 in an infrastructure.

8.Name of the Experiment: Evaluate performance of Multicasting Application

AIM-1: Configure and evaluate a multicasting application in a wired/wireless scenario.

9.Name of the Experiment: GSM Setup

AIM-1: Assembly of GSM set up and real time study of GSM 07.05 and 07.07 AT commands (such as network registration call control call setting etc at least 10 command).

10.Name of the Experiment: Wireless Sensor Network

AIM 1: To Interface analog sensor with Scientech 2311 Wireless sensor network.

11.Name of the Experiment: Temperature and Light Sensor

AIM 1:To develop a code to read temperature and light sensor data from sensor module attached to the radio module using SENSnuts GUI platform

12.Name of the Experiment: Level Based Routing

AIM 1:To create a LBR (level based routing) based multi-hop network using SENSnuts GUI platform.

Text Book:

1. Vijay K. Garg, “Wireless Communications and Networks”, Morgan Kaufmann Publishers an Imprint of Elsevier, USA 2009 (Indian reprint).

Reference Books:

1. Theidore S Rappaport, “Wireless Communication: Principles and Practice” Prentice Hall of India, New Delhi, 2006, 2/e.
2. Lab. Manuals concerning each experiment.

COURSE INFORMATION SHEET

FPGA & ASIC Design

Course Code: EC329

Course Title: FPGA & ASIC Design

Pre-requisite(s): Digital System Design

Co- requisite(s):

Credits: L: 3 T: 0 P: 0

Class schedule per week: 03

Class: B. Tech.

Semester / Level: VII

Branch: Electronics & Communication Engineering

Name of Teacher:

Course Objectives

This course envisions imparting to students to:

1.	Recognize the fundamental of Semicustom IC Design
2.	Show the importance of FPGA in Semicustom IC Design
3.	Analyze the combination & sequential processing unit through FPGA
4.	Show the importance of ASIC for the design, analysis, and synthesis of logic circuits
5.	Demonstrate the synthesis, modeling, model optimization and verification of digital circuit with VHDL & Verilog@HDL in the platform of FPGA & ASIC

Course Outcomes

After the completion of this course, students will be able to:

CO1	Recognize the importance of ASIC & FPGA in Semicustom ICs Design.
CO2	Design the optimize architecture using VHDL & implementation on FPGA
CO3	Develop the combinational & sequential processing unit for customized system using FPGA & ASIC.
CO4	Use the ASIC & FPGA for the design, analysis, and synthesis of logic circuits
CO5	Develop a digital system using VHDL & Verilog@HDL synthesis, modeling, model optimization, verification and implementation on FPGA & ASIC

SYLLABUS

MODULE	(NO. OF LECTURE HOURS)
Module – I FPGA Design: synthesis, simulation, porting ASIC designs, floor-planning and timing closure, design methodologies, performance, area and power optimizations, RTL coding, IP core selection. VHDL Design units and library. Process statement, Signal vs variable assignment, Sequential statements, For loop, While loop, Condition statements, Examples of half adder and full adder, Test bench.	8
Module – II FPGA Design Implementation Tools as VHDL: Data types, Scalar, Composite, Access type, File type; Arrays; Objects, Signal variables, Constants and files, Association lists, Interface lists, Structural description, Examples, Subprogram, Functions, Conversion function, Resolution functions, Procedures.	8
Module – III FPGA based VHDL Packages and Synthesis: Packages, Package declaration, deferred constants, Subprogram declaration. Simple gate - concurrent assignment, IF control flow statement, Case statement, Asynchronous preset and clear, Complex sequential statements. VHDL Design of Multiplexers, Decoders, Encoder, Code Converter, Flip-flops, Counters, Registers, Memory, Processors.	8
Module – IV ASIC Design Techniques: Full Custom ASICs, Standard Cell based ASICs, Gate Array based ASIC, Channeled Gate Array, Channel less Gate Array, Structured Gate Array, Programmable Logic Device, Field Programmable Gate Array, Economic of ASIC, Comparison between ASIC Technologies, Product Cost, ASIC variable cost, ASIC Cell Libraries.	8
Module – V ASIC Design Tools: Implementation of ASIC using Verilog@HDL, Synthesis in a design process, logic value system, Bit-widths, value holder and hardware modeling, Continuous Procedural assignment statement, Logical, arithmetic, relational & shift operators, vector operations, bit-selects, if, case statement, more on inferring latches, loop statement, Latch with preset and clear, modeling flip-flops, functions, tasks, gate level modeling.	8

Text Books:

1. FPGA Architecture for the Challenge". *toronto.edu*. University of Toronto.
2. "VHDL" by Douglas Perry, TMH, 1999.
3. VHDL Synthesis by J. Bhasker, BS Publication 2004.

4. Application Specific Integrated Circuits, Design & Implementation by Maurizrio Skerlj

5. Application Specific Integrated Circuits by M.J.S. Smith Addison- Wesley(1997).

Reference Books:

1. "Battle Over the FPGA: VHDL vs Verilog! Who is the True Champ?". *digilentinc.com*. Retrieved 2020-12-16.
2. Fundamental of Digital Logic with VHDL Design, by Stephen Brown I Zvonko Vranesic, The McGraw-Hill Companies.
3. Fundamental of Digital Logic with Verilog Design, by Stephen Brown I Zvonko Vranesic, The McGraw-Hill Companies
4. VERILOG HDL, A Guide to Digital Design and Synthesis, by Prabhu Goel, MULTI-D

Gaps in the syllabus (to meet Industry/Profession requirements): N/A

POs met through Gaps in the Syllabus: PO8 will be met though report writing/presentation-based assignment

Topics beyond syllabus/Advanced topics/Design: Teaching through paper

POs met through Topics beyond syllabus/Advanced topics/Design: Teaching through latest research paper

Course Outcome (CO) Attainment Assessment Tools & Evaluation Procedure

Direct Assessment

Assessment Tool	% Contribution during CO Assessment
First Quiz	10
Mid Semester Examination	25
Second Quiz	10
Teacher’s Assessment	5
End Semester Examination	50

Indirect Assessment

1. Students’ Feedback on Course Outcome.

Mapping of Course Outcomes onto Program Outcomes

Course Outcome	Program Outcomes (POs)												Program Specific Outcomes (PSOs)		
	1	2	3	4	5	6	7	8	9	10	11	12	13	14	15
CO1	3	3	3	3	3	2	3	3	3	2	3	2	2	3	2
CO2	3	3	3	3	3	2	3	3	3	3	3	2	2	3	2
CO3	3	3	3	3	3	2	2	2	2	2	2	2	2	3	1
CO4	3	3	3	2	3	3	2	3	2	3	2	2	2	3	1
CO5	3	3	3	3	3	3	2	2	2	2	3	2	2	3	1

Correlation Levels 1, 2 or 3 as defined below:

1: Slight (Low) 2: Moderate (Medium) 3: Substantial (High)

Mapping Between COs and Course Delivery (CD) methods

Code	Course Delivery Methods	Course Outcome	Course Delivery Method Used
CD1	Lecture by use of Boards/LCD Projectors	CO1	CD1, CD7, CD8
CD2	Tutorials/Assignments	CO2	CD1 and CD9
CD3	Seminars	CO3	CD1, CD2 and CD3
CD4	Mini Projects/Projects	CO4	CD1 and CD2
CD5	Laboratory Experiments/Teaching Aids	CO5	CD1 and CD2
CD6	Industrial/Guest Lectures		
CD7	Industrial Visits/In-plant Training		
CD8	Self- learning such as use of NPTEL Materials and Internets		
CD9	Simulation		

COURSE INFORMATION SHEET

Communication System

Course Code: **EC331**

Course Title: **Communication System**

Pre-requisite(s): Good understanding of mathematical tools like integration, differentiation etc.

Co-requisite(s):

Credits: L: 3 T: 0 P: 0

Class schedule per week: 03

Class: B.E. (ECE)

Semester / Level: 05 (Minor Course)

Branch: Any except ECE

Name of Teacher:

Course Objectives

This course aims to

1	Explain basics of analog and digital communication system and various modulation-demodulation schemes.
2	Explain the method to design analog and digital modulation-demodulation system
3	Explain the concept of sampling, quantization and coding required for various pulse modulation schemes.
4	Explain to evaluate the performance of communication system in the presence of noise.

Course Outcomes:

On the completion of this course, the students will be able to:

1	Demonstrate an understanding on communication system and representation of signals.
2	Demonstrate an understanding on different methods of analog and digital modulation and demodulation schemes, their design, operation and applications.
3	Demonstrate an understanding on multiplexing scheme and heterodyne receiver
4	Evaluate the performance of communication system in the presence of noise.

Syllabus

Module 1:

Overview of Electronic Communication Systems, Basic Blocks of Communication System, Need for Modulation, Amplitude (Linear) Modulation- AM, DSB-SC, SSB-SC, Methods of generation and detection of AM waves, DSB-SC & SSB-SC, Comparison between AM, DSB-SC and SSB-SC, Frequency Division Multiplexing.

Module 2:

Angle (Non-Linear) Modulation, Frequency and Phase Modulation, NBFM, WBFM, Transmission Bandwidth of FM signals, Methods of generation of FM wave and demodulation of FM wave, Superheterodyne Receivers.

Module 3:

Pulse modulation: Sampling Process, Pulse Modulation- PAM, PDM, PPM, Methods of generation and detection of PAM, PDM and PPM, Analog to Digital Conversion, Quantization Process, Pulse Code Modulation, Differential Pulse Code Modulation, Delta Modulation, Time Division Multiplexing.

Module 4:

Digital Modulation and Transmission: BASK, BFSK, and BPSK- Transmitter and Receiver, M-ary PSK, M-ary FSK and QAM, Spread Spectrum Modulation and its use, PN Sequence generation and its characteristics.

Module 5:

Noise in Communication System, Various Types of Noise, Noise Calculation, Equivalent Noise Bandwidth, Noise Temperature, Noise Figure. Shannon's Theorem, Channel Capacity, Bandwidth S/N Trade-off.

Text Book

1. Herbert Taub, Donald L Schilling and Gautam Saha "Communication Systems" McGraw Hill Education (India), pvt. Ltd., New Delhi, 4th edition, 2013.

Reference Books

1. Simon Haykin, "Communication Systems" Wiley, 4th edition, 2001.
2. D. Roddy & J. Coolen, "Electronics Communication", 4th Edition, PHI, 2005

COURSE INFORMATION SHEET

Communication Lab

Course code: EC332

Course title: Communication System Lab. **Pre-requisite(s):** Analog Communication

Co- requisite(s): Analog, Digital Communication

Credits: L: 0 T: 0 P: 2 C: 1.0 Class

schedule per week: 02 **Class:** B.

Tech.

Semester / Level: Fifth/Three **Branch:**

Electronics & Communication Lab

Name of Teacher:

Course Objectives:

This course enables the students:

6.	To develop an understanding about the Analog Modulation Techniques, V-F conversion and Butterworth LPF.
7.	To develop an understanding about the signal sampling, quantization and its reconstruction
8.	To develop an ability to understand and design the various waveform coding techniques
9.	To develop an ability to evaluate and design various digital modulation Techniques
10.	To develop an ability to evaluate and design Time Division Multiplexing Technique

Course Outcomes:

After the completion of this course, students will be able to:

CO1	Demonstrate understanding of the various Analog Modulation Techniques, V-F conversion and Butterworth LPF.
CO2	Analyse the signal sampling, quantization and its reconstruction.
CO3	Design the generation and detection of various waveform coding techniques such as PCM, DM and ADM
CO4	Design the modulators and demodulators for various digital modulation techniques such as ASK, PSK, FSK, QPSK, and QAM
CO5	Design system for Time Division multiplexing Technique

SYLLABUS

List of Compulsory experiments:

- 1. Name of the Experiment: Generation and detection of Amplitude Modulated**
AIM-1: Generation and detection of Amplitude Modulated wave and calculation of percentage modulation using ACL 01 and ACL 02 Kits
AIM-2: Design of Amplitude Modulation, DSB-SC, and SCB-SC Modulation and Demodulation Systems using ALTAIR Solid Thinking Embed/Comm.
- 2. Name of the Experiment: : Generation and detection of Frequency Modulated wave**
AIM-1: Generation and detection of Frequency Modulated wave using ACL 03 and ACL 04 FM trainer Kits
AIM-2: Design of Frequency Modulation and Demodulation Systems using ALTAIR Solid Thinking Embed/Comm.
- 3. Name of the Experiment: Generation and detection of PAM, PWM, PPM**
AIM-1: Generation and detection of PAM, PWM, PPM using DCL 08 Falcon kit.
AIM-2: Design of PAM, PWM, PPM Modulation and Demodulation Systems using ALTAIR Solid Thinking Embed/Comm.
- 4. Name of the Experiment: Design and implementation of 2nd and 4th order Low pass Butterworth filters**
AIM-1: Design and implementation of 2nd and 4th order Low pass Butterworth filters using Multisim
AIM-2: Design and implementation of 2nd and 4th order Low pass Butterworth filters
- 5. Name of the Experiment: Investigation of Signal Sampling and Reconstruction**
AIM-1: Investigation of Signal Sampling and Reconstruction using DCL 01 Falcon kit
AIM-2: Investigation of Signal Sampling and Reconstruction using ALTAIR Solid Thinking Embed/Comm
- 6. Name of the Experiment: Investigation of TDM system**
AIM-1: Investigation of TDM system using DCL02 Falcon kit
- 7. Name of the Experiment: Investigation of practical PCM system**
AIM-1: Investigation of practical PCM system using DCL03 and DCL04 Falcon kit
- 8. Name of the Experiment: Investigation of Delta Modulation system**
AIM-1: Investigation of Delta Modulation and Adaptive Delta modulation system using DCL07 Falcon kit
- 9. Name of the Experiment: Investigation of ASK, FSK, PSK modulation/demodulation**
AIM-1: Investigation of ASK, FSK, PSK modulation/demodulation using trainer kits
AIM-2: Design of ASK, PSK, FSK modulator/demodulator using ALTAIR Solid Thinking Embed/Comm

10. Name of the Experiment: Investigation of MSK modulation/demodulation

AIM-1: Investigation of MSK modulation/demodulation using trainer kits

AIM-2: Design of MSK modulator/demodulator using ALTAIR Solid Thinking Embed/Comm

11. Name of the Experiment: Investigation of QAM modulation and demodulation

AIM-1 : Investigation of QAM modulation and demodulation using ST 2112 QAM trainer kit

AIM-2: Design of QAM modulator/demodulator using ALTAIR Solid Thinking Embed/Comm

12. Name of the Experiment: Investigation of QPSK modulation and demodulation

AIM-1: Investigation of QPSK modulation and demodulation using ST 2112 QAM trainer kit

AIM-2: Design of QPSK modulator/demodulator using ALTAIR Solid Thinking Embed/Comm

Text Book:

1. “Principles of Communication Systems”, 2/e, by H. Taub and DL Schilling, Tata McGraw Hills, ND.
2. “Communication Systems”, 4/e by Simon Haykin, John Wiley and Sons, Delhi.

Reference Books:

3. Simon Haykin, “Communication Systems”, Wiley Eastern Limited, New Delhi, 2016, 4/e.
4. J. Schiller, “Mobile Communication” 2/e, Pearson Education, 2012.

COURSE INFORMATION SHEET

Digital Signal Processing

Course code: **EC369**

Course title: Digital Signal Processing

Programme: UG (ECE)

Academic Year:

Class/Semester:

Pre-requisites: Signals and Systems

Course Objectives:

1	To help understand the basic concepts of signals and systems, properties of discrete time system and concept of sampling theorem
2	To help to develop transfer function, predict frequency response of discrete-time systems and study of different transforms
3	To help to develop an ability to construct different types of structures for FIR and IIR filters
4	To help to design Butterworth and Chebyshev analog filters and IIR and FIR digital filters using different methods

Course Outcomes

On the completion of this course, the students will:

CO1	Be able to state sampling theorem and classify systems based on linearity, causality, shift-variance, stability criteria and represent transfer function of the selected system
CO2	Be able to evaluate system response of the system using convolution methods, frequency transformation technique, DTFT, DFT, DIF-FFT or DIT-FFT algorithm
CO3	Be able to design Butterworth filter, Chebyshev filter, FIR and IIR filters used as electronic filter, digital filter, mechanical filter, distributed element filter, waveguide filter, crystal filter, optical filter, acoustic filter, etc.
CO4	Be able to construct and recommend environment-friendly filter for real-time applications

Syllabus

MODULE – I

Introduction: Discrete-Time Signals, Shannon's sampling theorem, classification of signals, Difference equation description, properties of discrete time system (linearity, time-variance, convolution), BIBO stability, characteristics of system and time domain analysis, convolution, Z-transformation and its properties, Inverse Z-transform, their application in solving difference equations, Relationship between Laplace and Z-transforms.

MODULE – II

Frequency Domain Analysis: Discrete Time Fourier Transform (DTFT) and Discrete Fourier Transform (DFT), Periodic convolution, Direct evaluation of DFT, FFT algorithms- decimation in time and frequency, Relationship between Fourier and Z-transforms

MODULE – III

Digital Filter Structures: structures of FIR and IIR systems, Direct form I&II, cascade, parallel and ladder realizations.

MODULE – IV

Filter Design: Review of approximations of ideal analog filter response, Butterworth filter, Chebyshev Type I & II. Design of IIR Filter: Design based on analog filter approximations, Impulse invariance method, Matched Z-transformation, Bilinear transformation.

MODULE – V

Design of FIR Filters: Symmetric and antisymmetric FIR filters, design of linear phase FIR filters using windows and frequency – sampling methods, design of optimum equiripple linear phase FIR filters, comparison of FIR and IIR filters.

Text Books:

1. John G. Proakis, Dimitris G. Marmalakis, Digital Signal Processing, Principles, Algorithms and Applications
2. Alan V. Oppenheim Ronald W. Schaffer, Digital Signal Processing, PHI, India.

Reference Book:

1. Antonious, Digital Filter Design, Mc-Graw-Hill International Editions.

COURSE INFORMATION SHEET
Electronic Instrumentation

Course Code: EC371

Course Title: Electronic Instrumentation

Pre-requisite(s): EC101 Basics of Electronics & Communication Engineering

Co-requisite(s):

Credits: L:3 T:0 P:0 C: 3

Class schedule per week: 03

Class: B. Tech (Minor in ECE)

Semester / Level:

Branch: ECE

Name of Teacher:

Course Objectives:

This course envisions to impart students to:

1.	Understand the significance and characteristics of an Electronic Measurement System.
2.	Describe the transducer action and its classification.
3.	Discuss the use of signal conditioners, Data Acquisition system and Data loggers in real time measurement.
4.	Develop an ability to select and apply appropriate controller action.
5.	Examine the purpose of different communication protocols for signal transmission.

Course Outcomes:

After the completion of this course, students will be able to:

CO1	Explain the significance and characteristics of an Electronic Measurement System.
CO2	Demonstrate the use of transducers in measuring physical parameters.
CO3	Design an appropriate signal conditioner for real time signal acquisition using DAQ.
CO4	Implement different control schemes in managing real time process variables.
CO5	Apply communication protocols in managing process variables remotely.

SYLLABUS

MODULE	(NO. OF LECTURE HOURS)
Module – I Electronic Instruments and its classification, Elements of a Generalized Measurement System; Characteristics of instruments, Static characteristics, Errors in measurements, scale, range, and scale span, calibration, Reproducibility and drift, Noise, Accuracy and precision, Linearity, Hysteresis, Threshold, Dead time, Dead zone, Resolution and Loading Effects. Analog and Digital Instruments.	8
Module – II Transducers: Definition, Classification, Principle of Analog transducers: Resistive (Strain Gauge, POT, Thermistor and RTD), Capacitive, Piezoelectric, Thermocouple and Inductive (LVDT) and RVDT) transducer, Working principle of Digital Transducers and Optical transducers, Actuators: Pneumatic cylinder, Relay, solenoid (Final Control Element).	8
Module – III Introduction to Instrumentation system, Types of Instrumentation system, Data acquisition system, its objectives, and its uses in intelligent Instrumentation system, Detailed study of each block involved in making of DAS, Signal Conditioners: as DA, IA, Signal Converters (ADC & DAC), Sample and hold, Data logger.	8
Module – IV Concepts of Control Schemes, Types of Controllers, Continuous Controllers: P, PI, PID controllers, Discrete Controllers, Programable logic Controller (PLC), Intelligent Controllers.	8
Module – V Introduction to telemetry, Instrument interfacing, Current loop, RS232/485, Field bus, Modbus, GPIB, USB Protocol, HART communication Protocol-Communication modes and networks.	8

Books recommended:

Textbooks:

1. Electrical and Electronic Measurements and Instrumentation by A. K. Sawhney
2. Electronic Instrumentation by H. S. Kalsi.
3. Computer Based Industrial Control – By Krishna Kant, PHI

Reference Books:

1. Modern Electronic Instrumentation & Measurement Techniques” by Helfrich & Cooper.
2. Process Control Instrumentation – By Curtis D. Johnson, Pearson Education.

COURSE INFORMATION SHEET
Digital Signal Processing and Instrumentation Lab

Course code: EC372

Course title: Digital Signal Processing and Instrumentation Lab

Pre-requisites: Signals & System, Basic of MATLAB, C Language

Course Objectives

1	To understand the basics of Signal Processing via MATLAB implementation
2	To understand the Digital Signal Processor Architecture and it's functioning.
3	To develop MATLAB code and its application in signal processing.
4	To understand the working principle of different sensors
5.	To develop application specific virtual instrument

Course Outcomes

On the completion of this course, the students will be able to:

CO1	Demonstrate understanding of MATLAB with signal processing perspective
CO2	To apply the knowledge of MATLAB to various set of signal processing problems
CO3	To measure physical parameters using different sensors.
CO4	To develop virtual instrument using LabVIEW
CO5	Have the understanding and ability of developing a signal processing techniques for real life time problems.

LIST OF EXPERIMENTS:

1. Generation of the following sequence and to plot them using MATLAB:
 - a. Unit Sample Sequence $\delta[n]$
 - b. Unit Step Sequence $u[n]$
 - c. Ramp Sequence $n \cdot u[n]$
 - d. Exponential Sequences
 - e. Sine / Cosine Sequences
2. Computation of the linear convolution of two finite-length sequences using MATLAB
3. Obtaining the Partial Fraction Expansion of the Z-Transform expression and to find its Inverse Z-Transforms using MATLAB. Testing for the stability of given Discrete Time Systems using MATLAB
4. To write a MATLAB program for finding out the Linear and Circular Convolution of two finite-length sequences. Compare your result with that obtained by theoretical evaluation
5. Computation of N-point DFT and FFT of the length-N sequence using MATLAB

6. To write a program and simulate using C language / assembly language for computation of Linear Convolution using TMS 320C6478 DSK Processor
7. To write a MATLAB program to compute the Cross Correlation of two finite-length sequences. Compare your result with that obtained by theoretical evaluation.
8. Flow rate measurement using orifice and U tube manometer
9. Displacement measurement using LVDT
10. Temperature measurement using RTD, Thermistor and Thermocouple
11. Realization of lissajous figure using LabVIEW
12. Logic gate implementation using LabVIEW

Text Books:

1. Getting Started with MATLAB by Rudra Pratap, Oxford Publication
2. Digital Signal Processing: A computer-Based Approach by Sanjit K. Mitra, Mc-graw Hill
3. Digital Signal Processor: Architecture, Programming and Applications by B. Venkataramani and M. Bhaskar, Tata Mc-graw Hill
4. Process control instrumentation by C.D. Jhonson.8th edition, Pearson
5. LabVIEW user manual

Reference Books:

1. Digital Signal Processing using Matlab by Vinay K. Ingle and John J. Proakis, Cengage Learning.